

**AIRTECH
AIR COOLED
INSTALLATION,
OPERATING &
MAINTENANCE
INSTRUCTIONS**

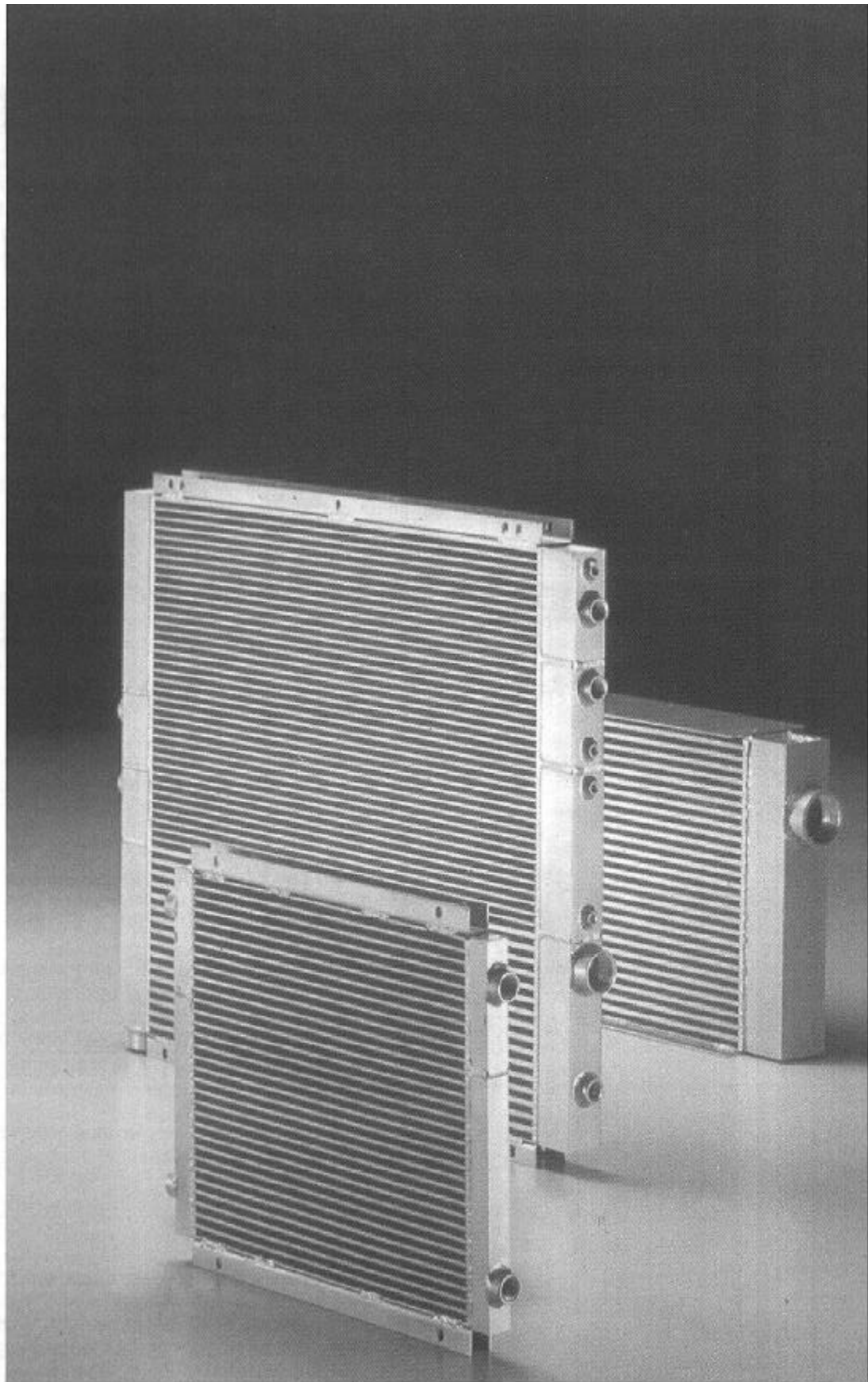

API Heat Transfer

...world leaders in heat transfer technology

INTRODUCTION: The information in this manual is intended to provide instruction for proper installation, operation and maintenance of air cooled heat exchangers and accessories manufactured by API Airtech, a division of API Heat Transfer. These instructions will supplement normal practices for equipment of this type and are not intended to cover each specific equipment item since construction details may vary. The user must assume the responsibility for the installation, operation and maintenance of this equipment by qualified personnel.

RECEIVING INSPECTION:

- Upon receipt of equipment, carefully check all parts for shortages and any type of damage. Do not remove item from shipping skid until a receiving inspection is completed and the material is found to be satisfactory.

- Shipping damage should be reported immediately, and a claim filed with the carrier.

INSTALLATION:

- Carefully lift the cooler assembly from the shipping skid, using the eyebolt or lifting brackets provided for that purpose. Some smaller units are not equipped with a lift point, in which case a woven fabric sling should be used to avoid damage to the unit. Do not use the cooler connections or manifolds to lift or move assembly, as severe damage may result.

- Some small models may require partial assembly of the supporting members. Use the fasteners and lock washers supplied with the unit. Be sure that they are securely tightened to withstand normal unit vibration. (See Fig. 1)

- The cooler should be located to permit the free movement of air around it. The warm discharge air must be free to dissipate to avoid recycling into the cooler inlet.

- The cooler must be installed level and the supports firmly anchored to a concrete pad or a major element of the building structure. Roof mounted units should be firmly anchored to building structural steel to avoid excess vibration. It is important that no vibration from other moving machinery is transmitted to the cooler supports.

- Adequate clearance should be provided around cooler and fan motor to permit proper maintenance.

- Aftercooler drain traps should be independently supported to avoid placing strain on cooler units.

- When it is necessary to provide air ducts, a duct area 50 percent greater than the fan opening is suggested. Pressure drop shall not exceed the equivalent of 30 feet of straight, round duct, with the cross section area 50 percent greater than fan opening. An access panel should be provided in the duct to service motor and fan. Fan guards should be left in place for air duct installations.

PIPING:

- All requirements of local codes should be followed.
- When connecting pipe fittings to the cooler, support the threaded coupling with a pipe wrench when tightening the connection. Use silicone sealant on all steel-to-aluminum threaded connections.
- All piping shall be firmly supported to avoid strain on cooler manifold and connections.
- Flexible connections shall be installed as shown on the schematic diagrams — Fig. 2 & 3 — to avoid transmitting compressor or pump vibrations to the cooler elements. To omit them will invalidate the warranty.
- Unions or flanges should be installed in the piping to permit installation or maintenance without major disruption of existing piping.
- All piping should be installed by qualified craftsmen in accord with current pipefitting standards and practice.
- Before beginning installation, check to be sure that no debris or foreign matter such as fragments of plastic shipping plug remain in the couplings or cooler bodies.
- Complete installation as indicated on the suggested piping diagram — Fig. 2 & 3.

MOISTURE SEPARATOR:

- Refer to typical piping schematic for placement of moisture separator and drain trap.
- The separator trap should discharge into an open drain so that its operation can be visibly monitored. It should never be connected into a closed drain which could create back pressure and resistance to flow.
- The separator should be rigidly supported on the floor or to the building structure.

ELECTRICAL:

- All local and national codes and regulations and standards should be followed for all electrical connections to the fan motor. Outdoor installations require appropriate weatherproof connections.
- All electrical connections should be made by qualified electricians who are familiar with all code requirements.
- The installation should include provision for a separate fused disconnect (furnished by others), so that the system may be isolated for service.
- Fan motors are usually multi-voltage and should be wired according to voltage requirements shown on the motor nameplate. Refer to specific motor instructions.
- Direction of fan rotation is important. Refer to the “fan rotation label”, either on the motor or fan housing, to determine proper direction of rotation.
- A conveniently located start/stop switch should be installed or the cooler fan motors may be wired directly to the compressor starting switch at the option of the user.

START-UP AND OPERATION:

- Check all piping joints for leakage prior to start-up. Pressurize system with air, and inspect connections with Leak-Tec solution.

FOR LIQUID COOLERS:

- Vent trapped air from system of liquid coolers.
- With air by-pass valves closed, open inlet and outlet valves to the cooler.
- Turn on power to fan at fused disconnect and/or switch.

FOR AIR AFTERCOOLERS:

- Turn on power to fan at fused disconnect and/or switch.
- With cooling fan operational, the compressor may then be started.
- When the system has been operating for approximately thirty minutes, check moisture separator trap discharge and continue to monitor it for proper operation. The amount of drainage will depend upon ambient humidity.

WARNING:

- Fan guard must be in place at all times while fan is operating.
- Heat exchanger must never be operated at a pressure higher than the maximum pressure shown on the cooler nameplate.

MAINTENANCE:

- Caution — Power should be disconnected and cooler depressurized prior to any repairs or adjustments. A valve should be installed on the vent connection on top of the cooler for depressurizing aftercooler. The cooler isolation valves should be closed before venting.
- Cleaning of the exterior fin surface may be required when discharge temperature increases beyond design conditions. Cleaning may be accomplished by low pressure steam lancing (with detergent added, if necessary). Caution — Do not use caustic base chemicals. Check with supplier of cleaning solution to insure compatibility with aluminum.
- Cleaning of the internal fin surfaces may be accomplished by circulating a degreaser solvent or cleaning solution through the internal passages. Caution — Solutions must be compatible with aluminum. Alkaline material should never be used.
- Operation of moisture drainage trap should be checked on a routine basis. The drain float trap valve should be examined approximately three months after initial start-up to establish a regular maintenance schedule. Cleaning of the drain valve and seat will vary with air quality. It is important that a trap by-pass be installed as shown to accommodate trap maintenance.

*If you have any questions, please call your
sales representative or the API Airtech factory direct @ 716-496-5755*

FIG. 1 LEG ASSEMBLY

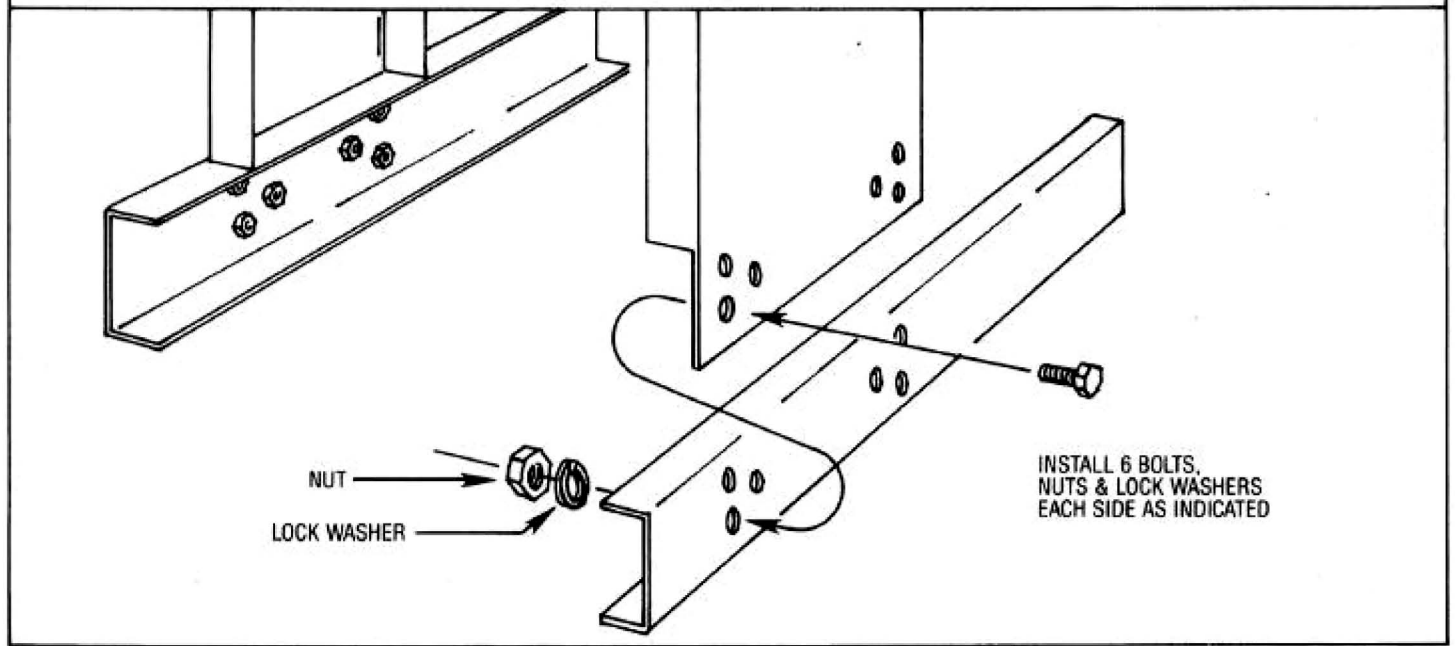

FIG. 2 SUGGESTED LIQUID COOLER INSTALLATION/FLOW DIAGRAM

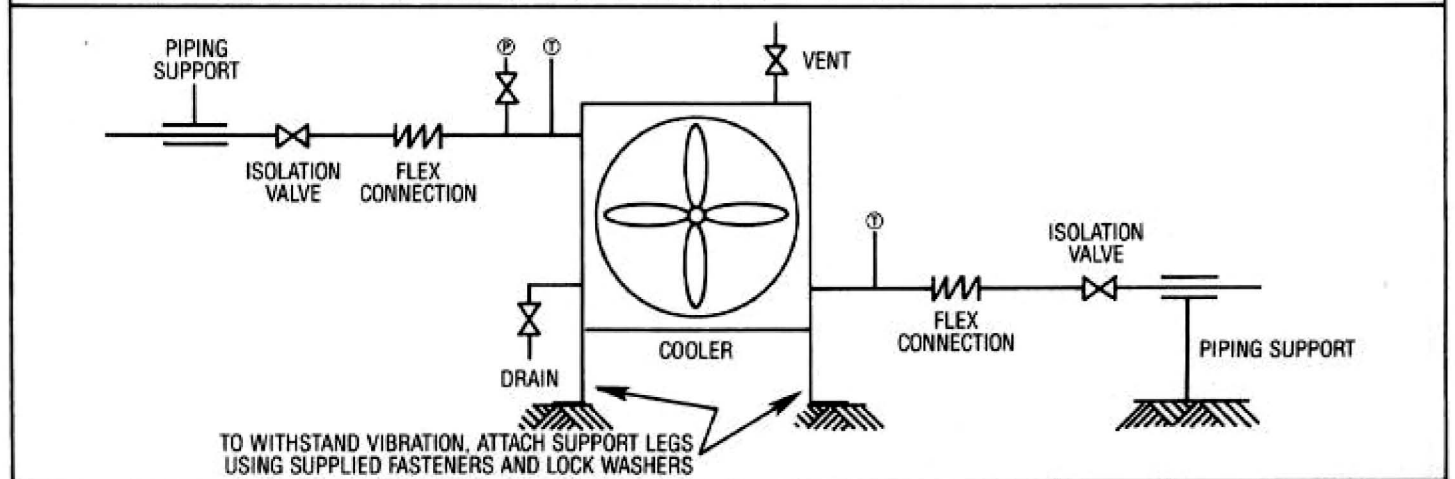
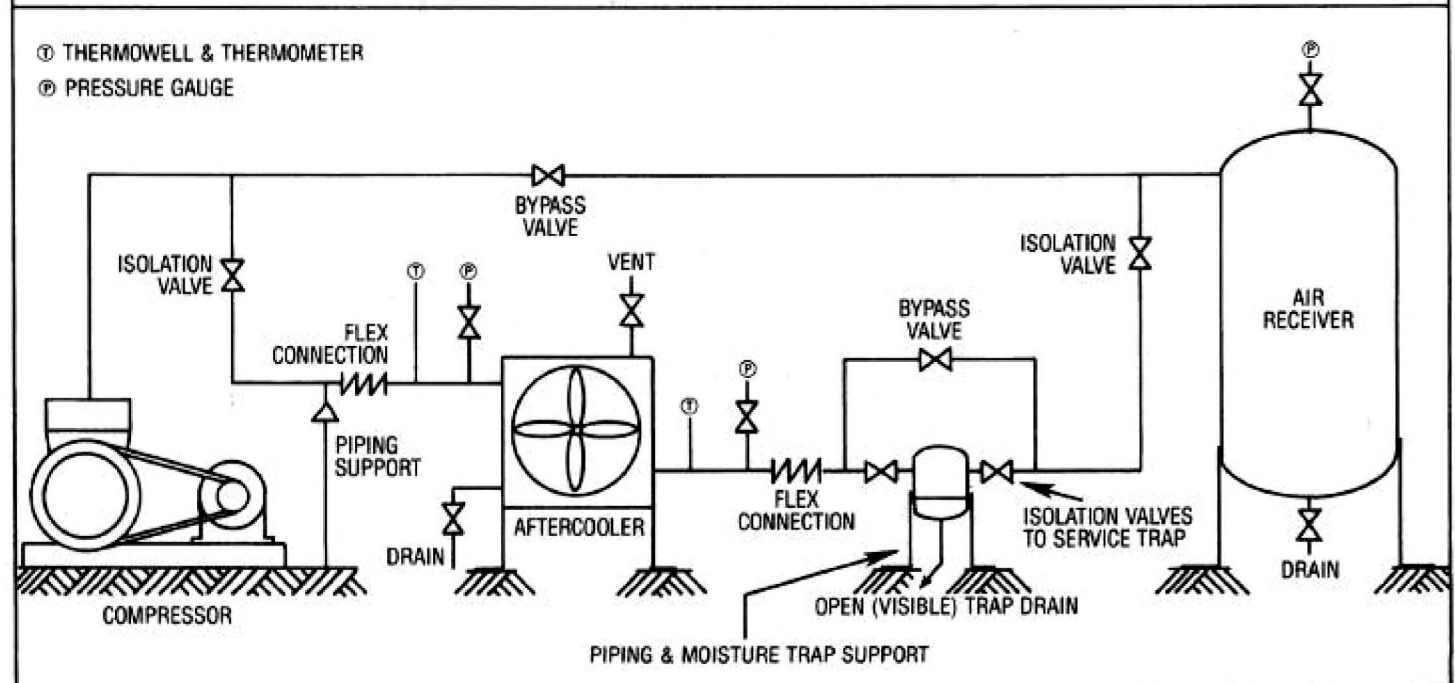

FIG. 3 SUGGESTED AFTERCOOLER INSTALLATION/FLOW DIAGRAM



API Heat Transfer

API Heat Transfer Inc.
2777 Walden Avenue
Buffalo, NY 14225
(716) 684-6700

Divisions:

API Airtech ISO-9001 Certified

Air Cooled Aluminum Heat Exchangers
91 North Street • P.O. Box 68
Arcade, New York 14009-0068
(716) 496-5755 • Fax: (716) 496-5776

API Basco ISO-9001 Certified

Basco/Whitlock Shell & Tube Heat Exchangers
2777 Walden Avenue
Buffalo, New York 14225
(716) 684-6700 • Fax: (716) 684-2129

API Ketema

Acme® Refrigeration Equipment
2300 West Marshall Drive
Grand Prairie, Texas 75051
(972) 647-2626 • Fax: (972) 641-1518

API Schmidt-Bretten

*Plate Heat Exchangers and
Thermal Process Systems*
2777 Walden Avenue
Buffalo, New York 14225
(716) 684-6700 • Fax: (716) 684-2129

API Schmidt-Bretten GmbH.

*ISO-9001 Certified
Plate Heat Exchangers and
Thermal Process Systems*
P.O. Box 1580 D-75005 Bretten
Pforzheimer Strasse 46
D-75015 Bretten, Germany
7252/53-101 • Fax: 7252/53-201

Distributed by:

TORRENT Engineering & Equipment

PO Box 270 Milford, IN 46542 USA
Phone (574) 658-3200 Fax (574) 658-3229 www.torrentee.com

Call your local API Sales Representative or
API directly toll-free at 1-877-API HEAT.

Visit us at www.apiheattransfer.com or
e-mail us at sales@apiheattransfer.com

Other Products Available from API Heat Transfer

OptiDesign®



Straight-tube, removable bundle exchangers made from standard components. Floating tube sheet for seal leak detection and easy maintenance. Diameters from 3" (7.62 cm) to 42" (106.68 cm). ASME, API, TEMA, ABS and other codes available.

Type 500 Shell and Tube Heat Exchangers

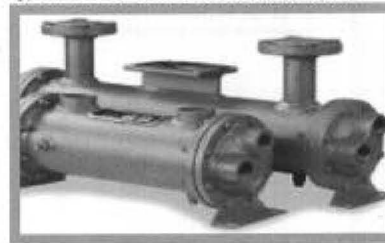

General purpose exchangers designed to cool oil, compressed air and other industrial fluids. A variety of constructions, port configurations and materials are available. ASME and TEMA-C available. Diameters from 3" (7.62 cm) to 12" (30.48 cm).

TEMA Shell and Tube

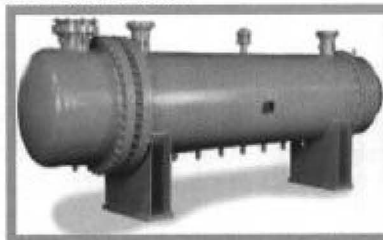

A wide variety of TEMA types are available using pre-engineered or custom designs in various sizes and materials. Shell diameters from 6" (15.24 cm) to 60" (152.4 cm). ASME, TEMA, API, ABS, TUV, ISPEL and other code constructions available.

Brazed Plate Heat Exchangers

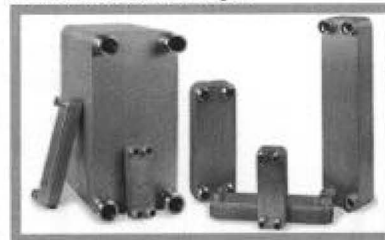

Off-the-shelf, standard units reflect the latest in plate heat exchanger technology for maximum performance and low cost. Ideal for OEM or aftermarket applications. Many models stocked and ready to ship. Models for process or refrigeration applications.

Pipeline Aftercoolers



Straight tube, counterflow aftercoolers designed to yield cool, dry compressed air. Available with or without accompanying moisture separators and constructed to a wide variety of design codes. Diameters from 6" (15.24 cm) to 42" (106.68 cm).

Moisture Separators

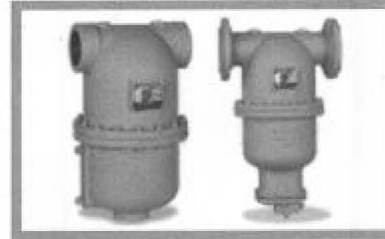

Compact centrifugal separators efficiently remove entrained moisture and solids from compressed air or gas streams. Available in capacities from 22 to 4,000 SCFM, the Type TC comes with an integral trap assembly and the Type T is designed for a remote trap.

Plate Heat Exchangers



Compact units provide excellent heat transfer and small size. Plates are pressed from stainless steel, titanium and other alloys. Gaskets of nitrile, EPDM, Viton®, compressed fiber and Teflon® are used. Gasket-free welded and brazed designs available.

ACME® Packaged Chillers

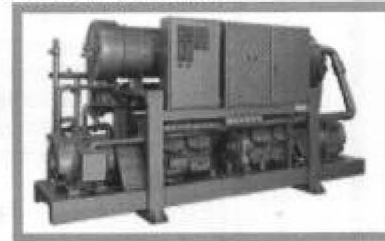

Packaged chillers with or without pumping systems from 3 to over 400 tons with PLC controls available. Standard and custom designed chiller-barrels and condensers to 2,500 tons with same-day shipment on many units. DX and flooded evaporators available.