

# Wafer and Globe Style Silent Check Valve

## Operation, Maintenance and Installation Manual

|                                |   |
|--------------------------------|---|
| INTRODUCTION .....             | 1 |
| RECEIVING AND STORAGE .....    | 1 |
| DESCRIPTION OF OPERATION ..... | 1 |
| INSTALLATION .....             | 2 |
| VALVE CONSTRUCTION .....       | 4 |
| MAINTENANCE .....              | 4 |
| TROUBLESHOOTING .....          | 5 |
| DISASSEMBLY .....              | 5 |
| REASSEMBLY .....               | 5 |
| PARTS AND SERVICE .....        | 5 |
| WARRANTY .....                 | 6 |



VAL-MATIC VALVE AND MANUFACTURING CORP.

905 RIVERSIDE DRIVE ■ ELMHURST, IL 60126  
PHONE (630)941-7600 ■ FAX (630)941-8042

# WAFER AND GLOBE-STYLE SILENT CHECK VALVE OPERATION, MAINTENANCE AND INSTALLATION

## INTRODUCTION

This manual will provide you with the information to properly install and maintain the valve to ensure a long service life. The Silent Check Valve is ruggedly constructed with bronze or stainless steel trim to give years of trouble-free operation. The valve should be installed in horizontal or vertical pipes carrying clean water. 14" and larger valves should be equipped with special springs for operation in vertical flow down applications.

The Silent Check Valve is designed to open fully to provide flow in the forward direction and close rapidly upon flow reversal. The valves are used to prevent reverse flow through pumps or in piping systems. The Size, Maximum Working Pressure, and Model No. are stamped on the nameplate for reference.

This valve is not intended for fluids containing suspended solids such as wastewater. For wastewater and other high turbidity applications, use Val-Matic Series 500 Swing-Flex® Check Valves.

|   |
|---|
| <b>CAUTION:</b> This valve is not intended for fluids containing suspended solids or hazardous gases. |
|---|

## RECEIVING AND STORAGE

Inspect valves upon receipt for damage in shipment. Unload all valves carefully to the ground without dropping. When lifting, the valve should be secured by the body and never lifted by the bronze or stainless steel trim.

The valves should remain crated, clean and dry until installed to prevent weather related damage. For long term storage greater than six months, the rubber surfaces of the seat (when provided) should be coated with a thin film of FDA approved grease such as Lubriko #CW-606. Do not expose rubber seat to sunlight or ozone for any extended period.

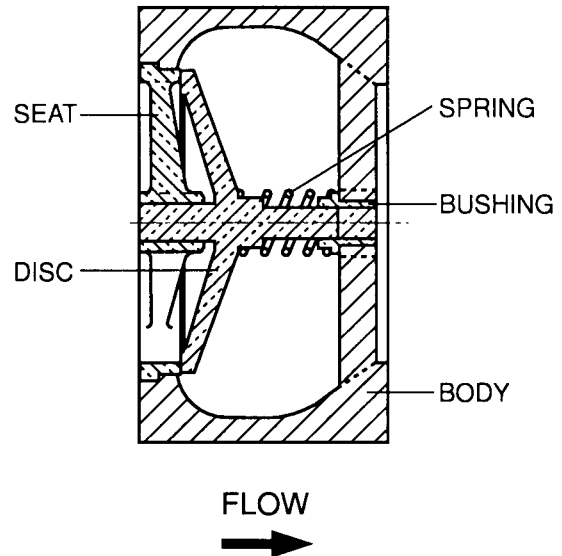

FIGURE 1. WAFER STYLE SILENT CHECK VALVE

## DESCRIPTION OF OPERATION

The silent check valve is designed to prevent reverse flow automatically. On pump start-up, the flow of water enters the valve from the seat end (left side in Figure 1) and forces the disc open, allowing the passage of fluid through the valve. On pump shut-down, the spring closes the disc before a flow reversal takes place. This type of closure, which prevents flow reversal, is the factor which allows "silent" operation and prevents water hammer associated with check valve slam.

The valve body is supplied with either compact wafer ends as shown in Figure 1 for installation between mating flanges or in a flanged configuration, Figure 2.

The only moving parts in the valve are the plug and spring. The body bushing controls the movement of the plug and assures that the plug contacts the seat evenly. The valve may have an optional resilient seal for drop tight service.

## INSTALLATION

The installation of the valve is important for its proper operation. The **flow arrow** on the valve body or nameplate must point in the direction of flow when the system is in operation. The valve can be installed in horizontal or vertical lines with the flow up or down. 14 inch and larger valves may require extra heavy springs for flow down applications; consult the factory.

When installed in horizontal lines, the check valve does not have a specific upward orientation. The valve is usually installed so that the nameplate is visible on the side of the valve for future reference.

The valve should be installed between standard flat-face flanges per ANSI B16.5 or AWWA C207. The installation requirements are illustrated in Drawing SS-974. The mating flange inside diameter must overlap the valve seat to provide proper seat retention. Flanges or pipes having an expanded inside diameter (ductile iron or mortar-lined pipe) cannot be used on the inlet side of the valve. A ring flange having the maximum inside diameter shown on the drawing must be inserted between the valve and mortar-lined pipe.

**CAUTION:** Mating flanges must be flat face or damage to the valve may result.

**WARNING:** Flanges having an expanded inside diameter (Mortar-Lined Pipe) cannot be used on the inlet side on the valve or damage may occur.

The ring-type flange gasket can be rubber or compressed fiber but should be a maximum of 1/16" thick with the diameters shown in Drawing SS-974. The gasket must overlap the bronze or stainless steel seat to provide a seal between the seat and the body.

When mating the check valve with butterfly isolation valves, the clearance between the butterfly disc and the fully open check valve stem must be checked. The location of the stem is also shown on the check valve submittal drawings. 10 inch and smaller flanged end check valves have sufficient clearance for most butterfly valves. However, on 12 inch and larger valves, the plug shaft extends beyond the flange face and may interfere with the operation of adjacent valves. A short run of pipe or spacer may be needed between the check valve and the isolation valve.

**FLANGED ENDS:** Flanged valves should be mated with flat-faced pipe flanges equipped with resilient gaskets. When ring gaskets are used, the bolt material shall be ASTM A307 Grade B or SAE Grade 2 Carbon Steel. Higher strength bolts should only be used with full-face gaskets.

**INSTALLATION:** Lower valve over mating flange using slings or chains around the valve body. Lubricate the flange bolts or studs and insert them around the flange. Lightly turn bolts until gaps are eliminated. The torquing of the bolts should then be done in graduated steps using the cross-over tightening method. Recommended lubricated torques for use with resilient gaskets (75 durometer) are given in Table 1.

If leakage occurs, allow gaskets to absorb fluid and check torque and leakage after 24 hours. Do not exceed bolt rating or crush gasket more than 50 per cent of its thickness.

| 125# FLANGE DATA |         |           |           | 250# FLANGE DATA |           |           |
|------------------|---------|-----------|-----------|------------------|-----------|-----------|
| VALVE SIZE       | BLT DIA | MIN. TORQ | MAX. TORQ | BLT DIA          | MIN. TORQ | MAX. TORQ |
| (in)             | (in)    | (ft-lbs)  | (ft-lbs)  | (in)             | (ft-lbs)  | (ft-lbs)  |
| 2-1/2            | 5/8     | 25        | 75        | 3/4              | 25        | 75        |
| 3                | 5/8     | 25        | 75        | 3/4              | 35        | 75        |
| 4                | 5/8     | 30        | 90        | 3/4              | 50        | 150       |
| 5                | 3/4     | 30        | 90        | 3/4              | 70        | 150       |
| 6                | 3/4     | 30        | 90        | 3/4              | 70        | 150       |
| 8                | 3/4     | 40        | 120       | 7/8              | 90        | 200       |
| 10               | 7/8     | 45        | 150       | 1                | 110       | 300       |
| 12               | 7/8     | 65        | 200       | 1 1/8            | 160       | 450       |
| 14               | 1       | 80        | 250       | 1 1/8            | 140       | 450       |
| 16               | 1       | 90        | 300       | 1 1/4            | 180       | 600       |
| 18               | 1 1/8   | 100       | 350       | 1 1/4            | 190       | 600       |
| 20               | 1 1/8   | 120       | 450       | 1 1/4            | 220       | 600       |
| 24               | 1 1/4   | 150       | 500       | 1 1/2            | 350       | 900       |
| 30               | 1 1/4   | 180       | 600       | 1 3/4            | 500       | 1500      |
| 36               | 1 1/2   | 250       | 750       | 2                | 700       | 2000      |
| 42               | 1 1/2   | 300       | 900       | 2                | 800       | 2500      |

**TABLE 1. FLANGE BOLT TORQUES**

**CAUTION:** The use of raised-face flanges or excessive bolt torque may damage flanges.

# SILENT CHECK VALVE INSTALLATION REQUIREMENTS

DAMAGE TO THE VALVE AND / OR INTERNAL LEAKAGE MAY RESULT IF PIPE FLANGES OTHER THAN THOSE WITH STANDARD FLAT FACES, CONFORMING TO ANSI B16.5 OR AWWA C207 ARE USED.

**WARNING NOTICE:** FLANGES HAVING AN EXPANDED INSIDE DIAMETER (OFTEN FOUND ON MORTAR LINED PIPE) CANNOT BE USED ON THE INLET SIDE OF THE VALVE. A RING FLANGE HAVING A MAXIMUM INSIDE DIAMETER, AS SHOWN IN "A" DIMENSION BELOW, MUST BE INSERTED BETWEEN THE VALVE AND MORTAR LINED PIPE FLANGE.

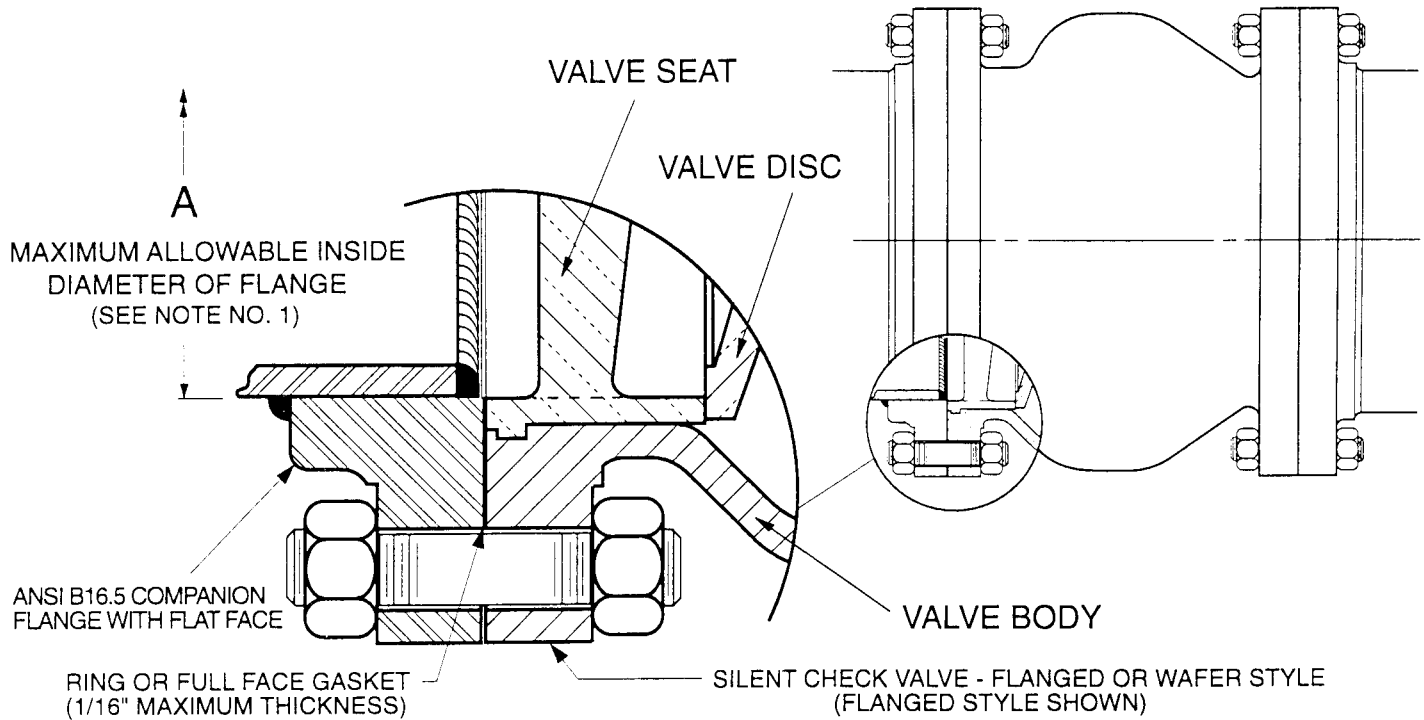

NOTE NO. 1 - THE MATING COMPANION FLANGE I.D. MUST OVERLAP THE VALVE SEAT. THIS IS REQUIRED TO PROVIDE PROPER SEAT RETENTION.

NOTE NO. 2 - THE FLANGE GASKET MUST BE PROPERLY CENTERED AND OF THE SIZE INDICATED. THIS IS REQUIRED TO ACHIEVE A SEAL BETWEEN THE SEAT O.D. AND THE BODY I.D. INTERFACE AREA.

| MAXIMUM ALLOWABLE INSIDE DIAMETER OF FLANGE (SEE NOTE NO. 1) |        |            |        |
|--|--------|------------|--------|
| VALVE SIZE   | A      | VALVE SIZE | A      |
| 2 1/2  | 2.940  | 14         | 14.140 |
| 3  | 3.570  | 16         | 16.160 |
| 4  | 4.570  | 18         | 18.180 |
| 5  | 5.660  | 20         | 20.200 |
| 6  | 6.720  | 24         | 24.250 |
| 8  | 8.720  | 30         | 30.250 |
| 10   | 10.880 | 36         | 36.250 |
| 12   | 12.880 | 42         | 42.250 |

| STANDARD RING GASKET DIMENSIONS (SEE NOTE NO. 2) |                                     |                         |                         |            |                                     |                         |                         |
|--|-------------------------------------|-------------------------|-------------------------|------------|-------------------------------------|-------------------------|-------------------------|
| VALVE SIZE                                       | I.D. FOR 125 LB. AND 250 LB. GASKET | O.D. FOR 125 LB. GASKET | O.D. FOR 250 LB. GASKET | VALVE SIZE | I.D. FOR 125 LB. AND 250 LB. GASKET | O.D. FOR 125 LB. GASKET | O.D. FOR 250 LB. GASKET |
| 2 1/2  | 2.875                               | 4.875                   | 5.125                   | 14         | 14.000                              | 17.750                  | 19.125                  |
| 3  | 3.500                               | 5.375                   | 5.875                   | 16         | 16.000                              | 20.250                  | 21.250                  |
| 4  | 4.500                               | 6.875                   | 7.125                   | 18         | 18.000                              | 21.625                  | 23.500                  |
| 5  | 5.562                               | 7.750                   | 8.500                   | 20         | 20.000                              | 23.875                  | 25.750                  |
| 6  | 6.625                               | 8.750                   | 9.875                   | 24         | 24.000                              | 28.250                  | 30.500                  |
| 8  | 8.625                               | 11.000                  | 12.125                  | 30         | 30.000                              | 34.750                  | 37.500                  |
| 10   | 10.750                              | 13.375                  | 14.250                  | 36         | 36.000                              | 41.250                  | 44.000                  |
| 12   | 12.750                              | 16.125                  | 16.625                  | 42         | 42.000                              | 48.000                  | 50.750                  |

Revised 5-12-98

SILENT CHECK VALVE FLANGE INSTALLATION REQUIREMENTS

DATE 4-7-96

**VAL-MATIC®**

VALVE AND MANUFACTURING CORP.

DRWG. NO.

SS-974

## VALVE CONSTRUCTION

The standard check valve body (1) is constructed of iron. See the specific Materials List submitted for the order if other than standard iron construction. The internal metal components are bronze or stainless steel. The disc (3) and spring (4) are the only moving parts and require no maintenance or lubrication. The general details of construction are illustrated in Figures 2 and 3.

The body (1) is either compact wafer style to fit between two pipe flanges or flanged style for connection to two pipe flanges. The seat (2) is retained in the body (1) with screws (6) to allow assembly into the pipeline. 2-1/2 inch and smaller valves have a threaded seat and no seat screws (6). The screws will not retain the seat against full line pressure. The mating flange must properly retain the seat. Do not remove the upstream flange while the pipeline is full of water or the seat (2) may become dislodged from the body.

**WARNING:** Removal of mating flanges without draining the pipeline may cause injury or damage to the valve.

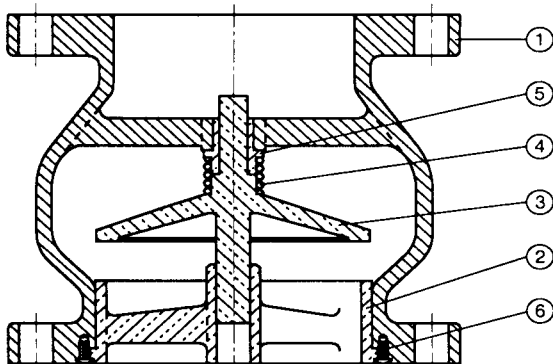

FIGURE 2. GLOBE STYLE CHECK VALVE

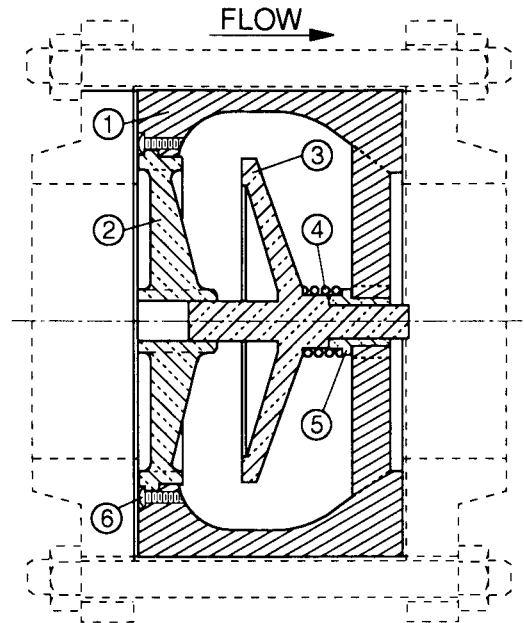

FIGURE 3. WAFER STYLE CHECK VALVE

| ITEM | DESCRIPTION | MATERIAL                             |
|------|-------------|--------------------------------------|
| 1    | Body        | Cast Iron                            |
| 2    | Seat*       | Bronze or SS                         |
| 3    | Disc*       | Bronze or SS<br>(optional Buna-N)    |
| 4    | Spring*     | Stainless Steel                      |
| 5    | Bushing*    | Bronze                               |
| 6    | Screw*      | Stainless Steel (3" & larger valves) |

\*RECOMMENDED SPARE PART

TABLE 2. CHECK VALVE PARTS LIST

## MAINTENANCE

Silent Check Valves require no scheduled lubrication or maintenance.

**INSPECTION:** Periodic inspection for leakage can be performed by listening for leakage noise from the valve while the pump is shut down. If leakage is heard, drain the pipeline, remove the valve, and inspect the seating surfaces for wear. Clean, lap, or repair trim as needed.

## TROUBLESHOOTING

Several problems and solutions are presented below to assist you in troubleshooting the valve assembly in an efficient manner.

● **Valve Chatters or Vibrates:** Verify that velocity is at least 4 ft/sec. Noise sounding like rocks in the line can be cavitation due to high velocities, low downstream pressure, or an upstream expander. Verify that there are 3 diameters of straight pipe upstream.

● **Valve Leakage:** Check upstream gasket and flange to verify that ID meets the maximum "A" dimension given in Drawing SS-974. Drain line, remove valve, and inspect seating surfaces.

● **Valve does not pass flow:** Check flow arrow direction on valve body. Verify that downstream isolation valve is open and there is no line blockage downstream.

● **Valve Slams:** Remove valve and inspect spring. Heavier springs can be furnished for severe applications.

## DISASSEMBLY

The valve should be removed from the pipeline for disassembly. All work on the valve should be performed by a skilled mechanic with proper tools. Refer to Figures 2 or 3.

|  |
|--|
| <b>WARNING:</b> The line must be drained before removing the valve or pressure may be released causing injury. |
|--|

1. Lay valve on flat surface or bench with flow arrow facing down. 12" and larger valves require support for the spring during disassembly. Place a 2x4 across the seat (2) and secure with C-clamps to the valve flange. Remove seat retaining screws(6) and seat (2). Note: 2" and 2-1/2" valves have threaded seats in lieu of retaining screws.
2. Examine narrow flange on the outside diameter of the seat (2). The retaining screws should have left a shallow dimple. If a deep depression is present, the gasket and flange internal diameters should be checked that they are greater than "A".
3. Flip the seat (2) over and inspect the seating surface. Some minor dents and discoloration are normal. Grooves or wear areas will cause leakage and requires seat replacement. Note: Replace seat if optional resilient seal is worn or damaged.

4. Lift disc (3) from body. Inspect shafts and seating surfaces for wear. The shaft diameter is normally about 1/32" smaller in diameter than the hole in the seat (2) and the bushing (5). Some minor dents and discoloration are normal. Wear areas will cause leakage and require seat replacement.
5. Remove spring (4) and check for wear or cracks.
6. Remove bushing (5) and inspect for wear. The inside diameter of the bushing should be about 1/32" larger in diameter than the shaft.

## REASSEMBLY

All parts must be cleaned and gasket surfaces should be cleaned with a stiff wire brush in the direction of the serrations or machine marks. Worn parts, gaskets and seals should be replaced during reassembly.

1. Insert bushing (5) into body (1). The bushing is retained by the spring.
2. Lay spring (4) and disc (3) over bushing.
3. Install seat (2) with retaining screws (6). 12" and larger valves may require the use of a 2x4 and C-clamps to compress the spring into the valve.
4. Install new gaskets and valve. Tighten flange bolts evenly using the cross-over tightening method and the torque values given in Table 1 on page 2.

## PARTS AND SERVICE

Parts and service are available from your local representative or the factory. Make note of the Valve Size and Model No. located on the valve nameplate and contact:

Val-Matic Valve and Mfg. Corp.  
905 Riverside Drive  
Elmhurst, IL 60126  
PH: 630/941-7600  
FAX: 630/941-8042

A sales representative will quote prices for parts or arrange for service as needed.

#### LIMITED WARRANTY

All products are warranted to be free of defects in material and workmanship for a period of one year from the date of shipment, subject to the limitations below.

If the purchaser believes a product is defective, the purchaser shall: (a) Notify the manufacturer, state the alleged defect and request permission to return the product; (b) if permission is given, return the product with transportation prepaid. If the product is accepted for return and found to be defective, the manufacturer will, at his discretion, either repair or replace the product, f.o.b. factory, within 60 days of receipt, or refund the purchase price. Other than to repair, replace or refund as described above, purchaser agrees that manufacturer shall not be liable for any loss, costs, expenses or damages of any kind arising out of the product, its use, installation or replacement, labeling, instructions, information or technical data of any kind, description of product use, sample or model, warnings or lack of any of the foregoing. NO OTHER WARRANTIES, WRITTEN OR ORAL, EXPRESS OR IMPLIED, INCLUDING THE WARRANTIES OF FITNESS FOR A PARTICULAR PURPOSE AND MERCHANTABILITY, ARE MADE OR AUTHORIZED. NO AFFIRMATION OF FACT, PROMISE, DESCRIPTION OF PRODUCT OF USE OR SAMPLE OR MODEL SHALL CREATE ANY WARRANTY FROM MANUFACTURER, UNLESS SIGNED BY THE PRESIDENT OF THE MANUFACTURER. These products are not manufactured, sold or intended for personal, family or household purposes.



VAL-MATIC VALVE AND MANUFACTURING CORP.

905 RIVERSIDE DRIVE ■ ELMHURST, IL 60126  
PHONE (630)941-7600 ■ FAX (630)941-8042