

The Model 310 is a loop powered, programmable transmitter capable of converting the signal from Data Industrial flow sensors to a linear 4-20mA analog signal. In addition to our standard square wave signal, it can also accept a sine wave making it a versatile transmitter for numerous applications.

With an onboard micro-controller and digital circuitry, the 310 is programmed from a computer eliminating the need to adjust potentiometers and producing precise, accurate and drift free signals. This will save both time and money by lowering overall maintenance times. This model also has an integral filter that the user can specify as 0 (to show true sensor readings) or 10 (for maximum dampening).

The compact cast epoxy body measures 1.75" (44mm) x 2.75" (70mm) x 1" (25mm) and can easily be mounted to panels, DIN rails or enclosures. With multiple inputs, ease of use and a variety of enclosures, the Model 310 is a powerful and competitive transmitter for many of today's demanding applications.

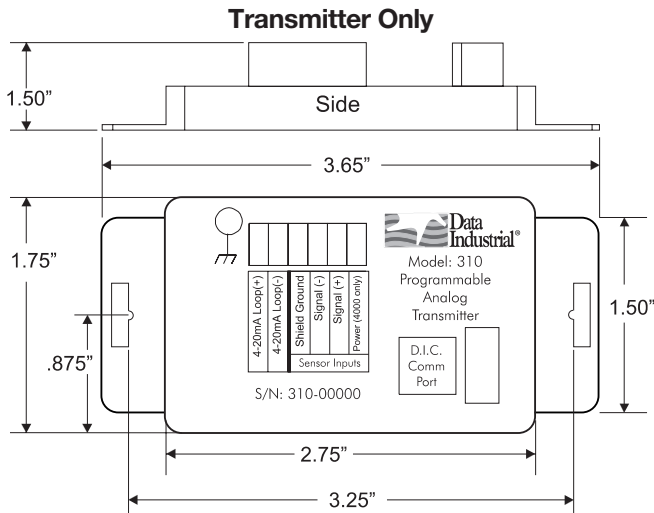

Optional Enclosure (ver. 310-02 & 310-03)

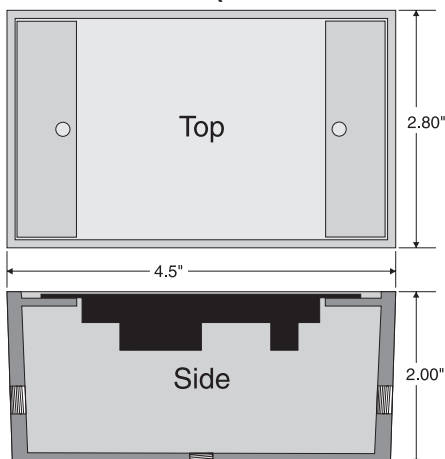

310 ORDERING MATRIX

		EXAMPLE:	310	-	xx
SERIES	Programmable Analog Transmitter		310		
OPTIONS	Transmitter Only				00
	W / NEMA 4X Enclosure				01
	W / Metal Enclosure				02
	W / Plastic Enclosure				03
	W / DIN Rail Mounting Clips				04

Specifications

Power Requirements:

— Loop Input Voltage 9-35VDC

Input Frequency:

— 0.4 to 10kHz

Load Resistance

— Max 750Ω@24VDC

Output Response Time

— Varies with filter

Temperature (operating):

— -29°C to 70°C

— -20°F to 158°F

Temperature (storage):

— -40°C to 85°C

— -40°F to 185°F

Accuracy

— ±0.04% of reading over entire span

Linearity

— 0.1% of full scale

Calibration

Units can be calibrated at our facility or easily programmed in the field. Field calibration requires a Data Industrial A310 Programming kit (consisting of a custom cable and software) and IBM compatible computer running a Windows® based operating system. In order to calibrate, the Model 310 must be connected to the loop for power, and the A301 cable must be connected to an available 9-pin COM port on the computer.

Once the software is loaded and communications with the transmitter are established, the following parameters are entered in the setup screens:

1. Units of measure
2. "K" and Offset values - selected from the sensor owners

manual or for insert style sensors entering the pipe I.D. allows the software to calculate the "K" and Offset values.

3. The flow rate represented by 4mA.
4. The flow rate represented by 20mA.

An added feature is a user selectable filter. Set for the minimum (0) the transmitter reacts to actual flow input. Set at the maximum (10) the transmitter provides the greatest dampening possible.

Once the values are set, the "send" command loads the transmitter.

All programming can be saved with a file name for later reference.

Wiring

Figure 1: Model 310

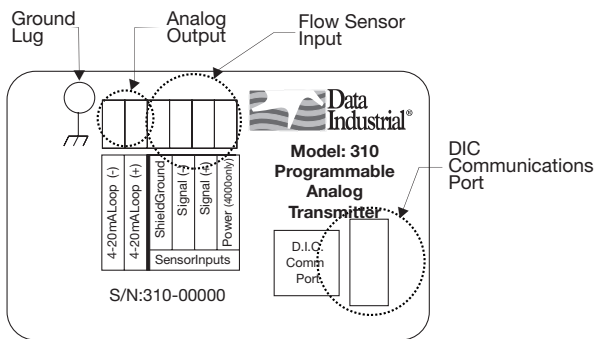

Per standard wiring practices, the loop power must be off before making any wire connections. The terminal strips have removable plug-in connectors to make wiring easier.

1. Refer to Figure 1 for terminal connections.
2. Connect loop power supply positive (+) to terminal marked 4-20mA loop (+)
3. Connect terminal marked 4-20mA loop (-) of Model 310 to positive analog terminal of input device (Chart Recorder, PLC, etc.)
4. Connect negative analog terminal of input device to loop power supply negative .
5. Wiring a Series 200 sensor, connect the red wire (signal) to Signal (+) terminal, black wire (ground) to Signal (-) terminal and the shield to Shield Ground terminal (Disregard shield for the IR sensors). If the sensor is not a Series 200, then go to step 6.
6. Wiring a Series 4000 sensor, connect the clear wire (signal) to Signal (+) terminal, black wire (ground) to Signal (-) terminal, shield wire to Shield Ground terminal, and red wire (power) to Power (4000 only) terminal.
7. For maximum EMI Protection, connect Model 310 ground log to panel ground.
8. Ensure that all connections are tight, then plug connector into header.

Figure 2: Wiring 310 to Series 200 or 4000 and Analog Loop

