

User's Manual

ACS550-PC/PD Packaged Drive with Disconnect Supplement to ACS550-01/U1 User's Manual



ACS550 Drive Manuals

GENERAL MANUALS

ACS550-U1 User's Manual (1...150 HP)

- Safety
- Installation
- Start-Up
- Embedded Fieldbus
- Fieldbus Adapter
- Diagnostics
- Maintenance
- Technical Data

ACS550 Technical Reference Manual (available in electronic format only)

- Detailed Product Description
- Practical Engineering Guides







ACS550-PC/PD Packaged Drive with Disconnect Supplement for ACS550-01/U1 User's Manual

- Safety
- Installation
- Start-Up
- Maintenance
- Technical Data

ACS550- CC/CF Packaged Drive with Bypass Supplement for ACS550-01/U1 User's Manual

- Safety
- Installation
- Start-Up
- Maintenance
- Technical Data

Safety

-  **WARNING!** The ACS550 adjustable speed AC drive with Input Disconnect should **ONLY** be installed by a qualified electrician.
-  **WARNING!** Even when the motor is stopped, dangerous voltage is present at the Power Circuit terminals U1, V1, W1 and U2, V2, W2 and, depending on the frame size, UDC+ and UDC-, or BRK+ and BRK-.
-  **WARNING!** Dangerous voltage is present when input power is connected. After disconnecting the supply, wait at least 5 minutes (to let the intermediate circuit capacitors discharge) before removing the cover.
-  **WARNING!** Even when power is removed from the input terminals of the ACS550, there may be dangerous voltage (from external sources) on the terminals of the relay outputs.
-  **WARNING!** When the control terminals of two or more drive units are connected in parallel, the auxiliary voltage for these control connections must be taken from a single source which can either be one of the units or an external supply.
-  **WARNING!** The ACS550 will start up automatically after an input voltage interruption if the external run command is on.
-  **WARNING!** When the ACS550 with Input Disconnect is connected to the line power, the Motor Terminals T1, T2, and T3 are live even if the motor is not running. Do not make any connections when the ACS550 with Input Disconnect is connected to the line. Disconnect and lock out power to the drive before servicing the drive. Failure to disconnect power may cause serious injury or death.
-

Note! For more technical information, contact the factory or your local ABB sales representative.

Use of Warnings and Notes

There are two types of safety instructions throughout this manual:

- Notes draw attention to a particular condition or fact, or give information on a subject.
- Warnings caution you about conditions which can result in serious injury or death and/or damage to the equipment. They also tell you how to avoid the danger. The warning symbols are used as follows:

-  **Dangerous voltage warning warns of high voltage which can cause physical injury and/or damage to the equipment.**
-



General warning warns about conditions, other than those caused by electricity, which can result in physical injury and/or damage to the equipment.

Table of Contents

Safety

Use of Warnings and Notes	1
---------------------------------	---

Table of Contents

Installation

Application	4
Input Disconnect Features and Functions	4
Installation Flow Chart	6
Preparing for Installation (Supplement to ACS550-01/U1 User's Manual)	7
Installing the Drive (Supplement to ACS550-01/U1 User's Manual)	9
Installing the Wiring (Supplement to ACS550-01/U1 User's Manual)	11

Maintenance

Maintenance Intervals	16
Drive Module Fan Replacement	16
Enclosure Fan Replacement – NEMA 12 Enclosures	17
Enclosure Air Filter Replacement – NEMA 12 Enclosures	18

Technical Data

Ratings (Supplement to ACS550-01/U1 User's Manual)	22
Input Power Connections (Supplement to ACS550-01/U1 User's Manual) ...	23
Motor Connections	30
Cooling – R7/R8	30
Dimensions and Weights (Supplement to ACS550-01/U1 User's Manual) ...	31
Applicable Standards	40

Index

Installation

Study these installation instructions carefully before proceeding. **Failure to observe the warnings and instructions may cause a malfunction or personal hazard.**



WARNING! Before you begin read "Safety" on page 1.



WARNING! When the ACS550 with Input Disconnect is connected to the line power, the Motor Terminals T1, T2, and T3 are live even if the motor is not running. Do not make any connections when the ACS550 with Input Disconnect is connected to the line. Disconnect and lock out power to the drive before servicing the drive. Failure to disconnect power may cause serious injury or death.

Application

This manual contains supplemental information that is unique to ACS550 input disconnect configurations (PC or PD). Refer to the base manual, AC550-01/U1 User's Manual, for all other information.

Input Disconnect Features and Functions

The ACS550 with Input Disconnect is an ACS550 AC adjustable frequency drive packaged with an input disconnect switch or circuit breaker, and with a door mounted, external operating handle. The operating handle can be padlocked in the OFF position (padlock not supplied). Enclosure options are NEMA 1, NEMA 12, and NEMA 3R (UL Type 1, UL Type 12, and UL Type 3R).

The following is a typical power diagram.

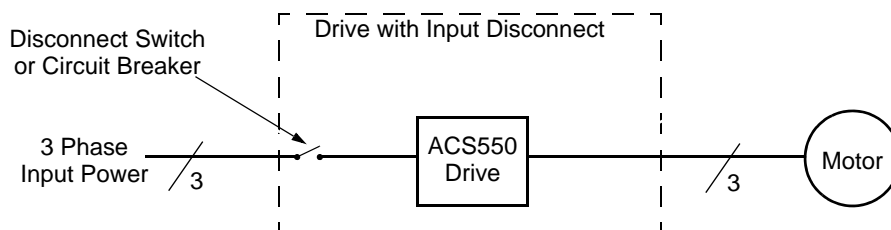

The following figures show the front view of the ACS550 Input Disconnect standard configurations, and identify the major components.

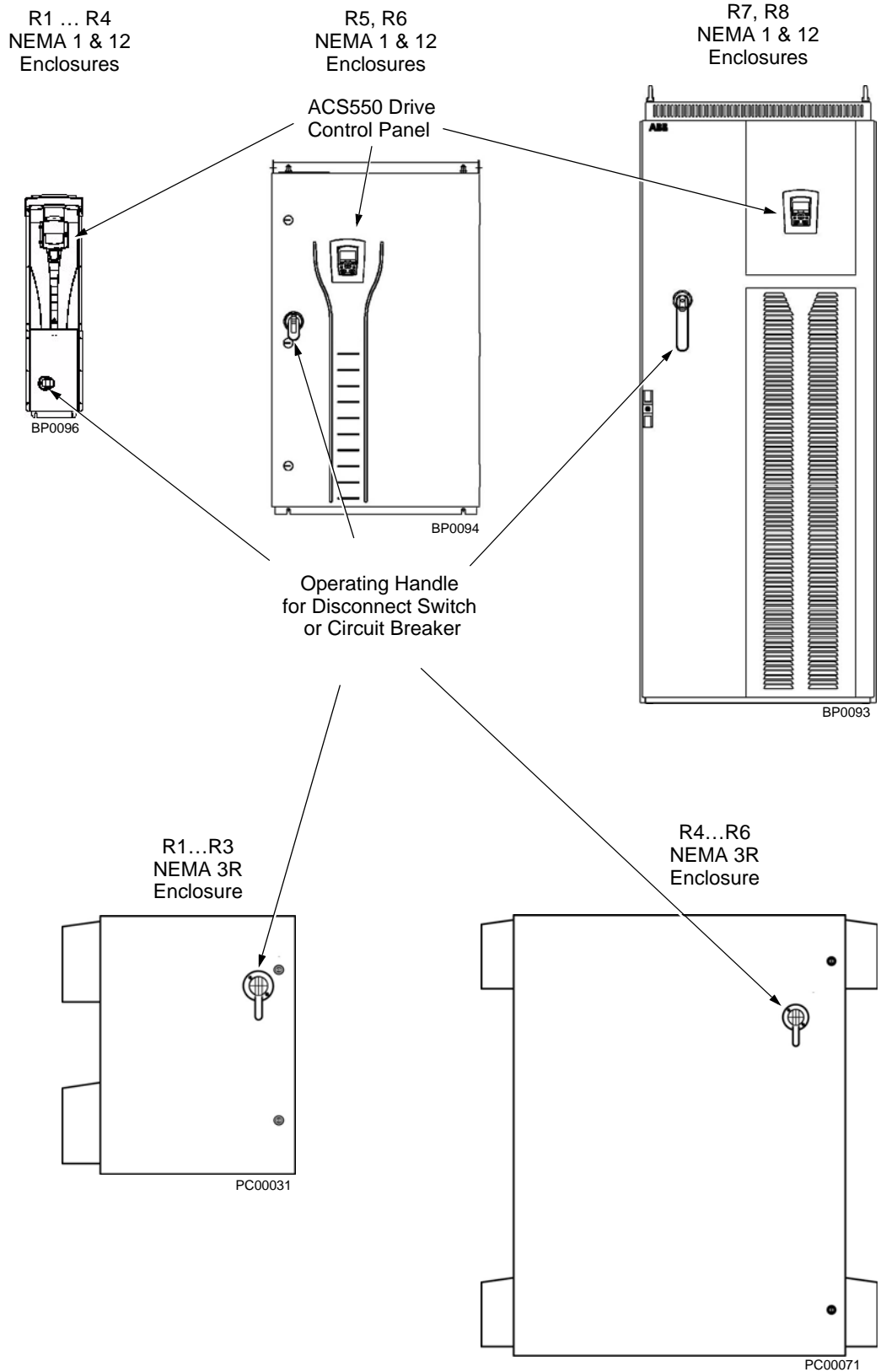

Installation Flow Chart

The installation of Input Disconnect configurations for ACS550 drives follows the outline below. The steps must be carried out in the order shown. At the right of each step are references to the detailed information needed for the correct installation of the unit.

Note! References in the middle column below are to the ACS550-01/U1 User's Manual. References in the third column below are to this manual.

Task	Refer to the ACS550-01/U1 User's Manual "Installation" section	Additional Reference in this Manual
PREPARE for installation	"Preparing for Installation"	<ul style="list-style-type: none"> • R7/R8: "Lifting the Drive" on page 7. • "Drive Identification" on page 8. • "Suitable Mounting Location" on page 9.
PREPARE the Mounting Location	"Prepare the Mounting Location"	<ul style="list-style-type: none"> • R7/R8: "Prepare the Mounting Location – R7 and R8" on page 9. • "Dimensions and Weights (Supplement to ACS550-01/U1 User's Manual)" on page 31.
REMOVE the front cover	"Remove Front Cover"	R7/R8: "Remove Side Panel- R7 and R8 NEMA 1 and 12 Enclosures" on page 10.
MOUNT the drive	"Mount the Drive"	R7/R8: "Mount the Drive" on page 10.
INSTALL wiring	"Wiring Overview" and "Install the Wiring"	"Installing the Wiring (Supplement to ACS550-01/U1 User's Manual)" starting on page 11.
CHECK installation	"Check Installation"	--
RE-INSTALL the cover	"Re-install Cover"	--
APPLY power	"Apply Power"	--
START-UP	"Start-Up"	--

Preparing for Installation (Supplement to ACS550-01/U1 User's Manual)

Lifting the Drive

R7...R8



Warning! Handle and ship floor mounted enclosures only in the upright position. These units are not designed to be laid on their backs.

1. Use a pallet truck to move the package/enclosure to the installation site.
2. Remove the cabinet side panels from NEMA 1 and 12 enclosures for access to the cabinet/pallet mounting bolts. (6 torx screws hold each cabinet side panel in place. Leave the side panels off until later.)
3. Remove the 4 bolts that secure the cabinet to the shipping pallet.



PC00005

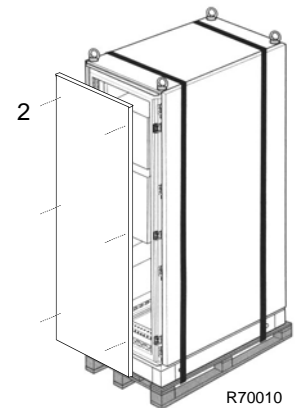

R70010



Warning! Use the lifting lugs/bars at the top of the unit to lift R7/R8 drives.

4. Use a hoist to lift the drive. (Do not place drive in final position until mounting site is prepared.)



PC00003

Preparing for Installation (Supplement to ACS550-01/U1 User’s Manual)

Drive Identification

To identify the type of device you are installing, refer to the type code number on the device identification label.

- Wall mounting base drives – label attached on the side surface of the heat sink.
- Packaged drive with screw cover – label attached to outside surface on the left side of the enclosure.
- Enclosure with hinged cover/door – label on inside surface of the cover/door.

Type Code Number

Use the following to interpret the type code found on the identification label.

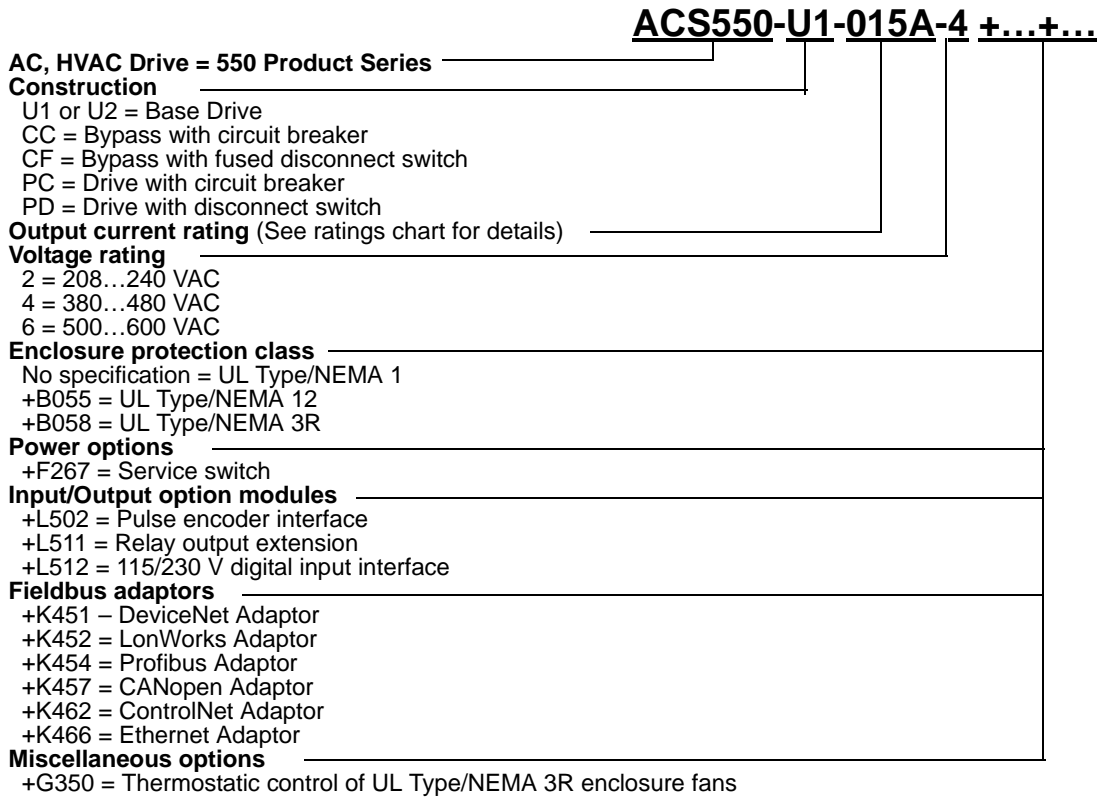

Ratings and Frame Size

Charts in the “Ratings” sections of the ACS550-01/U1 User’s Manual and this manual list technical specifications, and identify the drive’s frame size.

Note! Some instructions in this document vary, depending on the drive’s frame size. To read the Ratings table, you need the “Output current rating” entry from the type code (see above).

Suitable Mounting Location

For selecting a suitable mounting location for PC/PD configurations, refer to:

- Preparing for installation in the ACS550-01/U1 User's Manual, and
- The Technical Data section of this manual for information on dimensions and weights.

Installing the Drive (Supplement to ACS550-01/U1 User's Manual)



Warning! Metal shavings or debris in the enclosure can damage electrical equipment and create a hazardous condition. Where parts, such as conduit plates require cutting or drilling, first remove the part. If that is not practical, cover nearby electrical components to protect them from all shavings or debris.

Prepare the Mounting Location – R7 and R8

The ACS550 should only be mounted where all of the requirements defined in "Preparing for Installation" are met.

Frame sizes R7 and R8 have mounting holes inside the enclosure base. See "NEMA 1 & 12, R7...R8 Mounting Dimensions" on page 33.

Where it is not possible to use either mounting hole at the back of the base, use an L-bracket at the top of the enclosure to secure the cabinet to a wall or to the back of another enclosure. Bolt the L-bracket to the enclosure using the lifting lug bolt hole on the top of the enclosure.

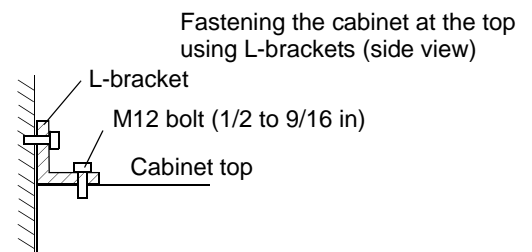
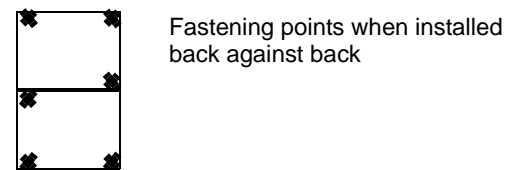
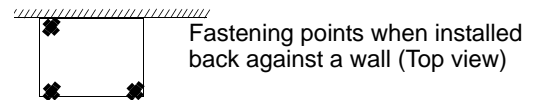
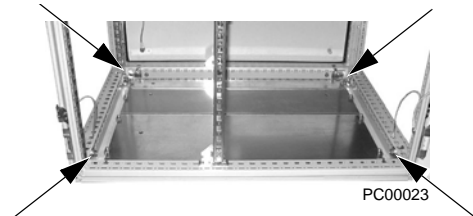

Remove Side Panels – R7 and R8 NEMA 1 and 12 Enclosures

Cabinet Door

1. To open the cabinet door, loosen the quarter-turn screws that hold the cabinet door closed.
2. Installation access is easier if these panels are kept off throughout the installation.

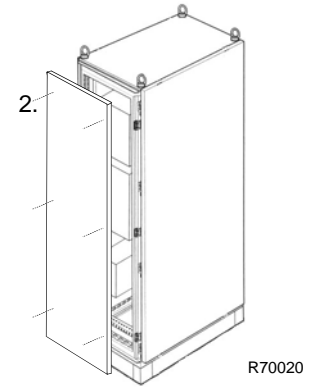

Mount the Drive

R7...R8

1. Use a hoist to move the cabinet into position.

Note! If the cabinet location does not provide access to the cabinet sides, be sure to re-mount side panels before positioning cabinet.

2. Install and tighten mounting bolts.



Installing the Wiring (Supplement to ACS550-01/U1 User's Manual)



WARNING!

- **Metal shavings or debris in the enclosure can damage electrical equipment and create a hazardous condition. Where parts, such as conduit plates require cutting or drilling, first remove the part. If that is not practical, cover nearby electrical components to protect them from all shavings or debris.**
 - **Do not connect or disconnect input or output power wiring, or control wires, when power is applied.**
 - **Never connect line voltage to drive output Terminals T1, T2, and T3.**
 - **Do not make any voltage tolerance tests (Hi Pot or Megger) on any part of the unit. Disconnect motor wires before taking any measurements in the motor or motor wires.**
 - **Make sure that power factor correction capacitors are not connected between the drive and the motor.**
-

Wiring Requirements

Refer to the “Wiring Requirements” Section in the ACS550-01/U1 User's Manual. The requirements apply to all ACS550 drives. In particular:

- Use separate, metal conduit runs for the following different classes of wiring:
 - Input power wiring.
 - Motor wiring.
 - Control/communications wiring.
- Properly and individually ground the drive, the motor and cable shields.

Wiring Overview

Power Connection – Standard Input Disconnect (R1...R6, Wall Mounted)

The following figures show the Standard Input Disconnect (wall mounted) wiring connection points. Refer to the ACS550-01/U1 User's Manual for control connections to the drive.

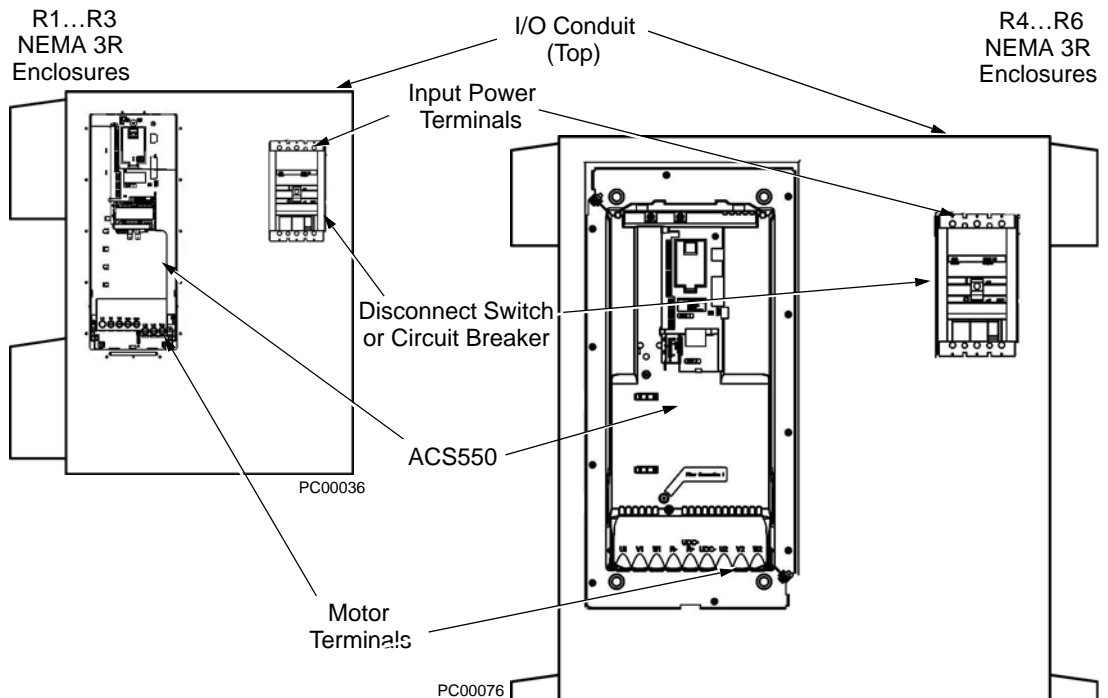
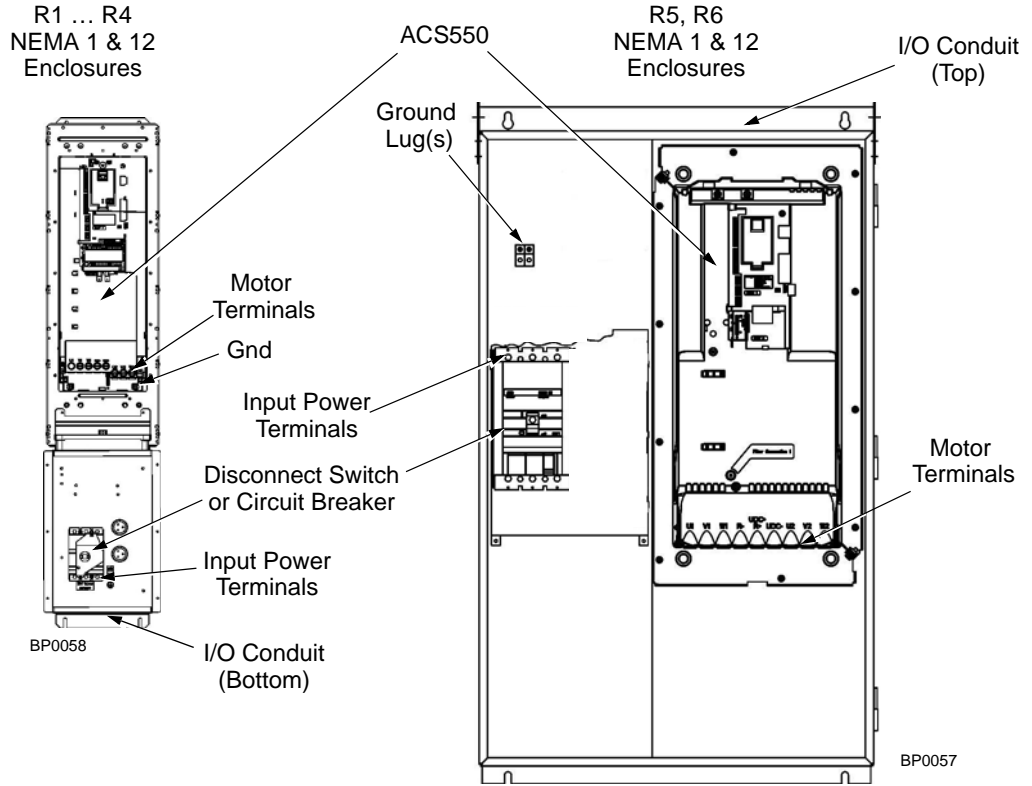

Power Connection – Standard Input Disconnect (R7...R8, Floor Mounted)

The R7 and R8 ACS550 Standard Input Disconnect units are configured for wiring access from the top and include a removable conduit mounting plate. The following figure shows the Standard Input Disconnect (floor mounted) wiring connection points. Refer to the ACS550-01/U1 User's Manual for control connections to the drive.

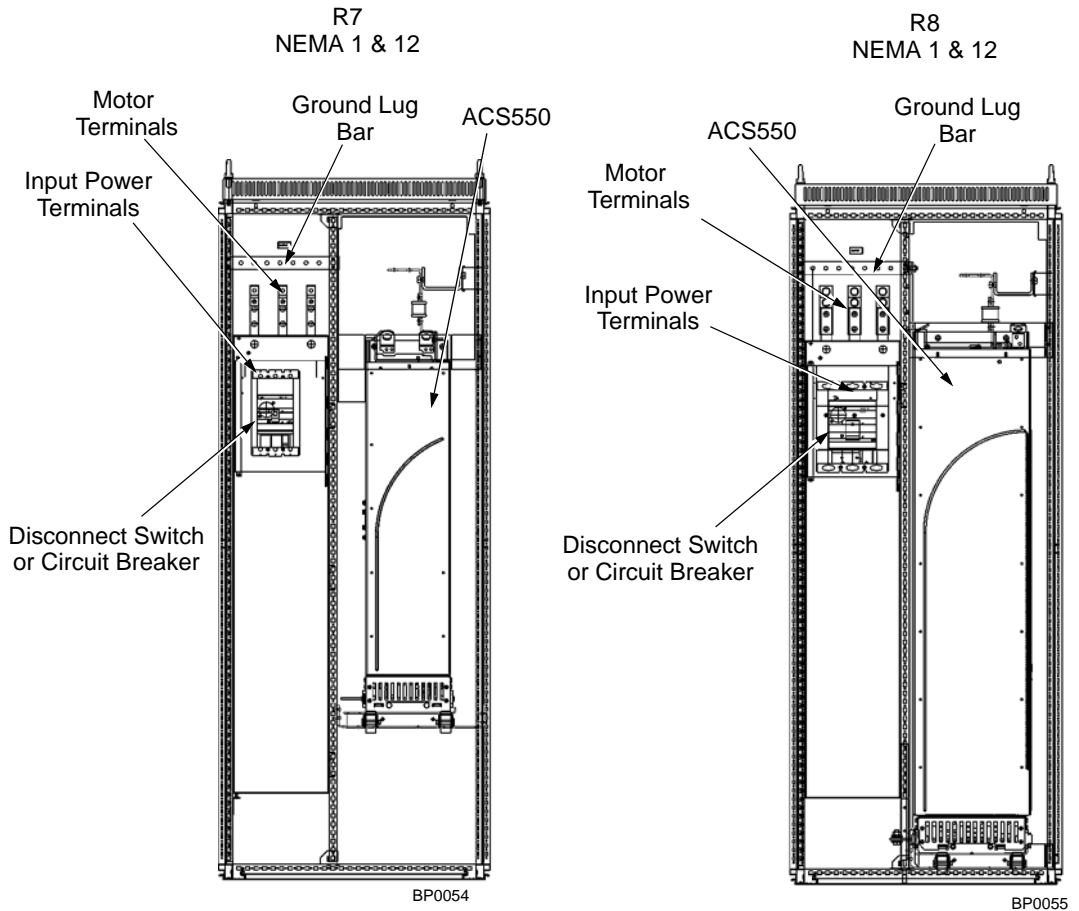

Install the Line Input Wiring

Line Input Connections – Standard Input Disconnect Configurations

Connect input power to the terminals of the disconnect switch or circuit breaker. Connect the equipment grounding conductor to the ground lug. The figure below shows the connection points for Standard Input Disconnect configurations.

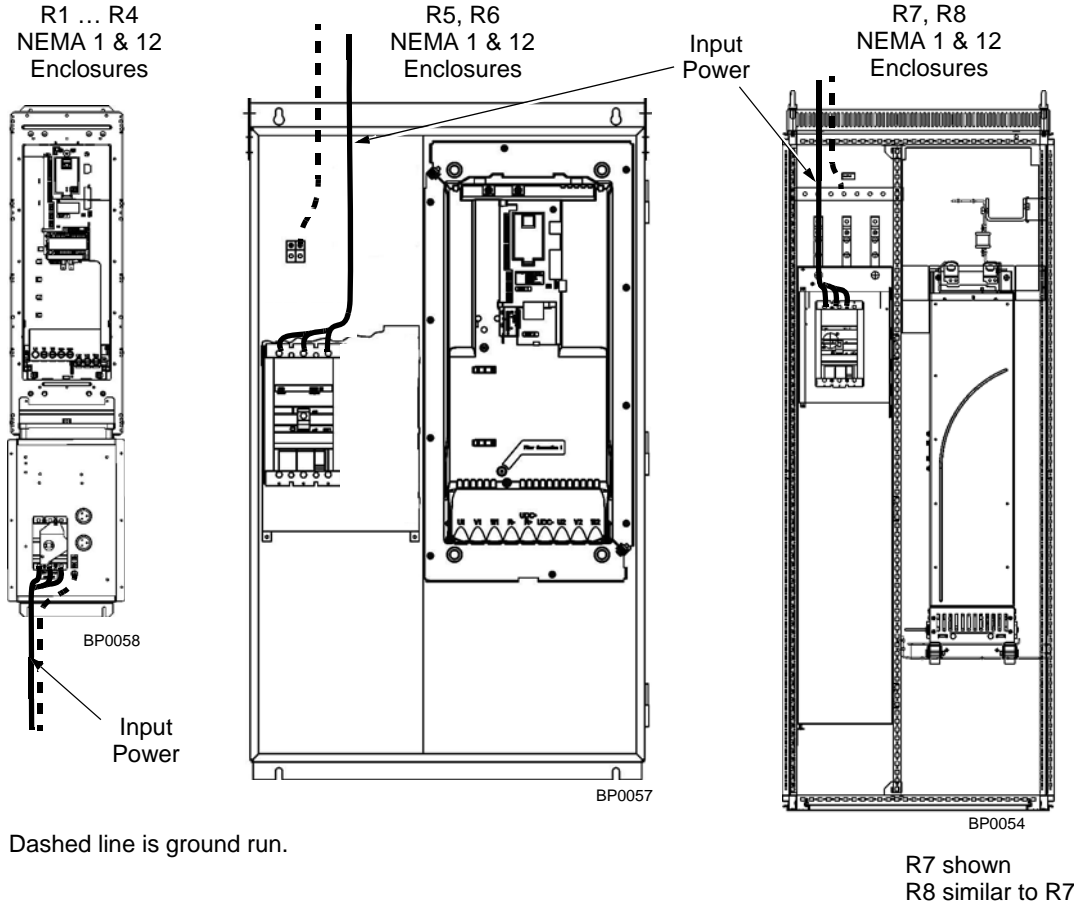

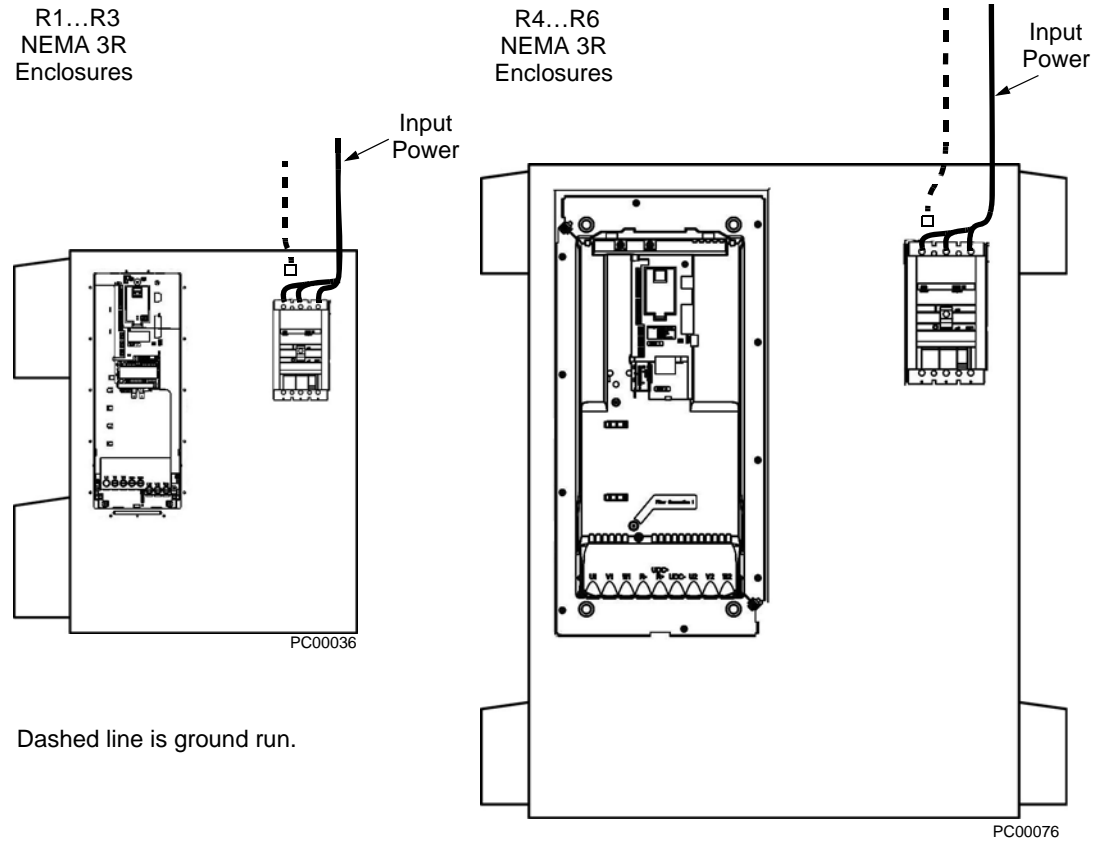

WARNING! Check the motor and motor wiring insulation before connecting the ACS550 to line power. Follow the procedure in the ACS550-01/U1 User's Manual. Before proceeding with the insulation resistance measurements, check that the ACS550 is disconnected from incoming line power. Failure to disconnect line power could result in death or serious injury.

Note! For the remainder of the installation and start-up (motor and control wiring) refer to the ACS550-01/U1 User's Manual.

Maintenance

Maintenance Intervals

If installed in an appropriate environment, the drive requires very little maintenance. This table lists the routine maintenance intervals recommended by ABB.

Maintenance	Configuration	Interval	Instruction
Check/replace R5/R6 enclosure inlet air filter	R5/R6 NEMA 12 enclosures	Check every 3 months. Replace as needed.	"Frame Sizes R5/R6 – Enclosure Inlet Air Filter" on page 18
Check/replace R7/R8 enclosure inlet air filter	R7/R8 NEMA 12 enclosures	Check every 3 months. Replace as needed.	"Frame Sizes R7/R8 – NEMA 12 Enclosure Inlet Air Filter" on page 19
Check/replace R7/R8 enclosure exhaust air filter.	R7/R8 NEMA 12 enclosures	Check every 6 months. Replace as needed.	"Frame Sizes R7/R8 – NEMA 12 Enclosure Exhaust Filters" on page 20
Check/replace NEMA 3R enclosure air filters	NEMA 3R enclosures	Check every 3 months. Replace as needed.	None (self evident).
Check and clean heatsink.	All	Depends on the dustiness of the environment (every 6...12 months)	See "Maintenance" in ACS550-01/U1 User's Manual.
Replace drive module fan.	All	Every six years	See "Maintenance" in ACS550-01/U1 User's Manual.
Replace enclosure fan(s).	NEMA 12 enclosures	Every three years.	See "Frame Sizes R7/R8 – NEMA 12 Enclosures" on page 17, For other frame sizes, see "Maintenance" in ACS550-01/U1 User's Manual.
Change capacitor.	Frame sizes R5 and R6	Every ten years	See "Maintenance" in ACS550-01/U1 User's Manual.
Replace battery in the Assistant control panel	All	Every ten years	See "Maintenance" in ACS550-01/U1 User's Manual.

Drive Module Fan Replacement

The drive module fan cools the heatsink. Fan failure can be predicted by the increasing noise from fan bearings and the gradual rise in the heatsink temperature in spite of heatsink cleaning. If the drive is operated in a critical part of a process, fan replacement is recommended once these symptoms start appearing. Replacement fans are available from ABB. Do not use other than ABB specified spare parts.

To monitor the running time of the cooling fan, see "Group 29: Maintenance Trig" in the ACS550-01/U1 Users's Manual.

Frame Sizes R7 and R8

Refer to the installation instructions supplied with the fan kit.

Enclosure Fan Replacement – NEMA 12 Enclosures

NEMA 12 enclosures include an additional fan (or fans) to move air through the enclosure.

Frame Sizes R7/R8 – NEMA 12 Enclosures

The enclosure fan is located in the exhaust box on top of the NEMA 12 enclosure.

1. Remove the left and right filter frames of the exhaust fan box by lifting them upwards.
2. Disconnect the fan's electrical connector from the cabinet roof (top right inside the cabinet).

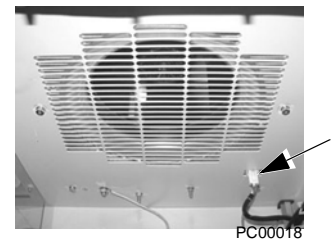
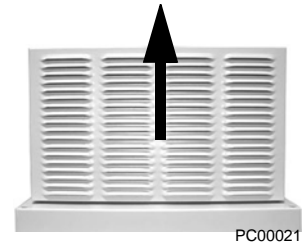

3. Undo the four fastening screws at the corners of the fan frame. The screws are through bolts with nuts on the inside of the cabinet. (Do not drop the hardware into the drive).

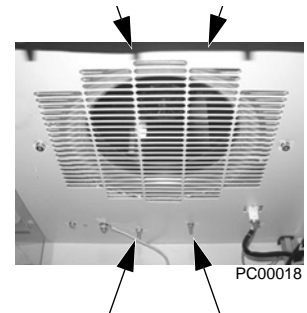
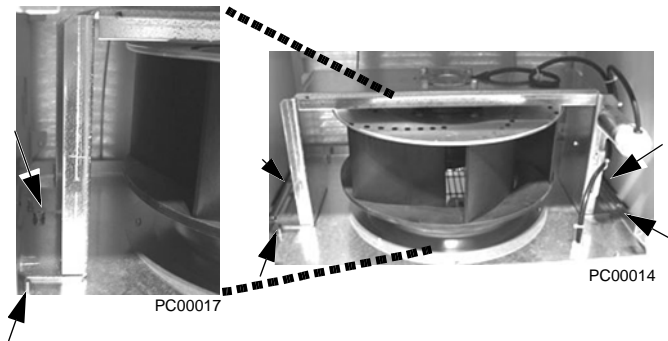

4. Remove the fan and fan frame as one unit.

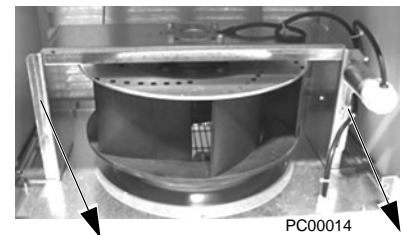

5. Disconnect the fan wiring and capacitor from the fan frame. Then remove the four screws attaching the fan to the fan frame. Remove the old fan.

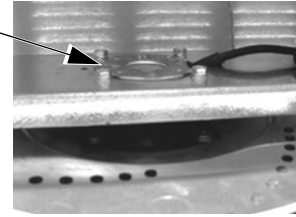

PC00020

6. Install the new fan and capacitor with the replacement part for ABB in the reverse order of the above. Ensure the fan is centered on the velocity stack and rotates freely.

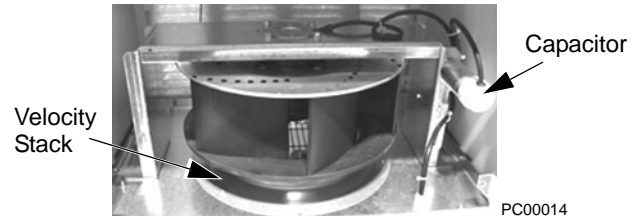

PC00014

Enclosure Air Filter Replacement – NEMA 12 Enclosures

Frame Sizes R5/R6 – Enclosure Inlet Air Filter

This procedure applies to disconnect configurations in R5 and R6 frame sizes with NEMA 12 enclosures. This filter is located at the bottom of the enclosure. Use the following procedure to check and replace filters.

1. On the enclosure, remove the screw holding the filter bracket in place.
2. Slide the filter bracket forward until the hooks on the bracket clear the slots on the enclosure base. This step allows the filter and bracket to drop free from the enclosure.

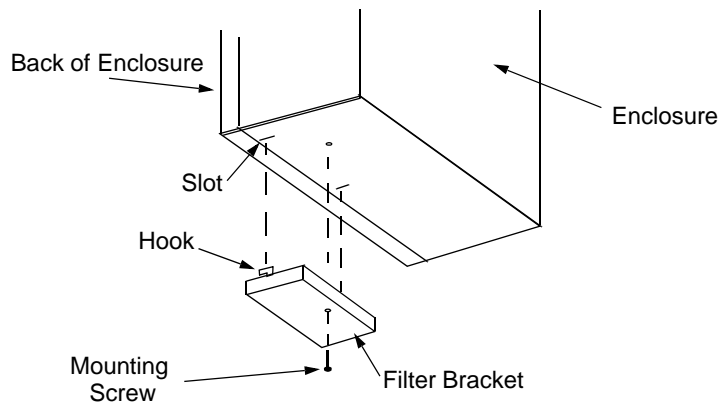

3. Lift the filter out of the filter bracket and replace as appropriate.
4. With the filter in the filter bracket, align the hooks on the bracket with the slots in the enclosure base, and press the hooks up into the slots.
5. Slide the filter bracket back, making sure that the hooks catch on the enclosure.
6. Replace the mounting screw. Tighten until the gasket on the bracket is about 50% compressed.

Frame Sizes R7/R8 – NEMA 12 Enclosure Inlet Air Filter

The inlet air filter for the R7/R8 NEMA 12 enclosure is located in the enclosure front door.

1. While holding the top of the filter frame, pull up on the bottom of the frame. The filter frame will slide up approximately 3/4 inch and can then safely removed by tilting away from the cabinet and lifting up.



PC00015

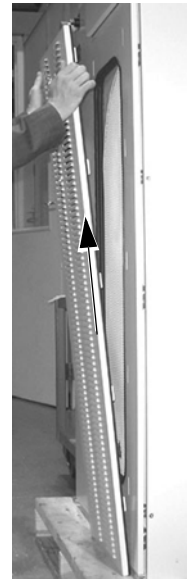

PC00010

2. Lay the filter frame on a flat work surface. Remove the 3 retaining brackets by squeezing the tabbed corners in towards the middle of each bracket until the bracket clears the filter frame. Save these brackets for replacement. Remove and inspect the filter.

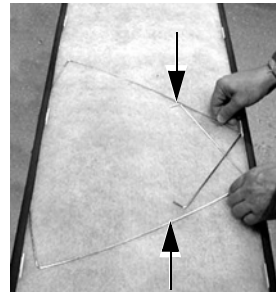

PC00009

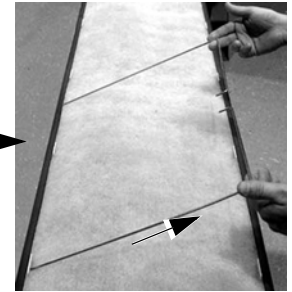

PC00007

3. Install the replacement filter. Be sure to tuck the filter into the groove around the entire filter frame. This is very important for proper installation.



PC00013

4. Reinstall the 3 filter restraining brackets. These will prevent the filter from being pulled out of the filter frame.
 - Install the center bracket first.
 - Install the 2nd bracket overlapping the center bracket by 1/2 to the left.

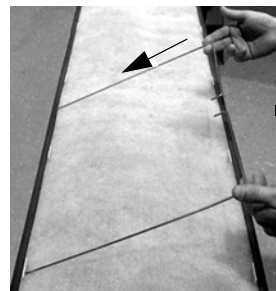

PC00007

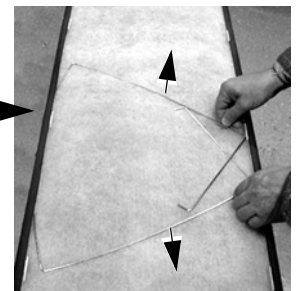

PC00009

- Install the 3rd bracket overlapping the center bracket by $\frac{1}{2}$ to the right.

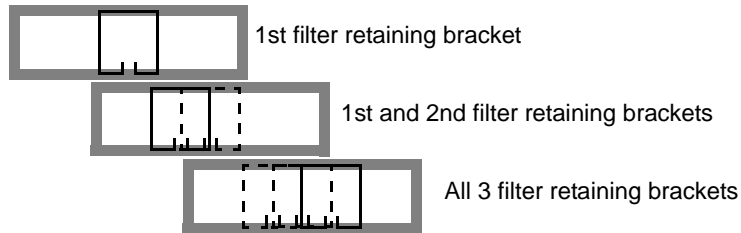

5. Install the filter frame back to the cabinet door. Carefully align the mounting hooks to the slots in the cabinet door. The hooks should be pointing down. Press in at the center of the filter frame with your knee and gently press down with your hands at the top of the frame. The filter frame will slide down approximately $\frac{3}{4}$ inch and should be sealed securely to the door around the entire filter frame.



PC00006

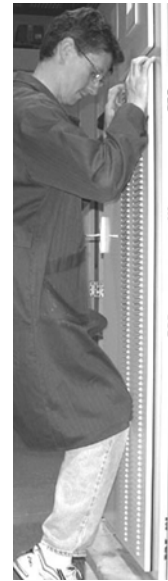

PC00008

Frame Sizes R7/R8 – NEMA 12 Enclosure Exhaust Filters

The exhaust filters in the R7/R8 NEMA 12 enclosure are located in the exhaust box at the top of the enclosure.

There are 2 filter frames attached to the exhaust box.

1. Remove each filter frame:
 - Lift up on the filter frame until it slides approximately $\frac{3}{4}$ inch.
 - Pull away from the exhaust box to remove.
2. For each filter frame, remove the wire retainers that hold the filters in place:
 - Lay the filter frames on a flat work surface.
 - The wire retainers have a square "U" shape. Remove by squeezing the open end of the

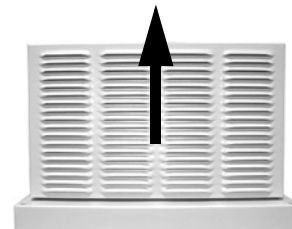

PC00021

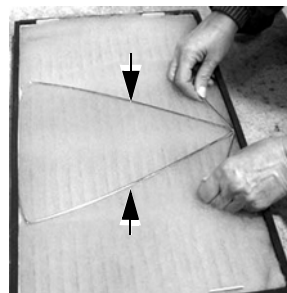

PC00001

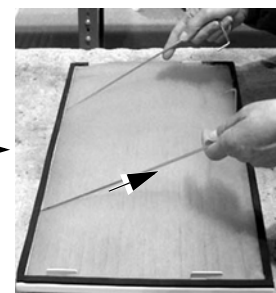

PC00019

“U” towards the middle of the “square” until the retainer top (open end of “U”) clears the filter frame.

- Save the retainers for reinstallation.
3. Remove and inspect the filter.
 4. Install clean filters.

Note! When installing DUSTLOK® filter media, the white side must face to outside of the cabinet, and the orange side faces in.

Be sure to tuck the filter edges into the groove around the entire filter frame. This detail is very important for proper operation.

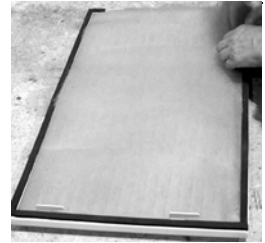

PC00022

5. Reinstall the filter restrainers.

- Insert the base of a retainer (bottom of “U” shape) into a filter frame channel.
- Squeeze the open end of the “U” until it clears the filter frame.
- Seat the open end of the “U” in the filter frame channel.
- Release the retainer to its relaxed, square shape.

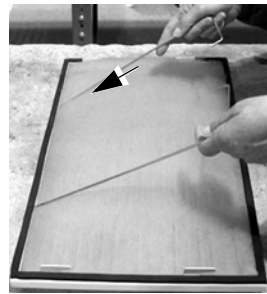

PC00019

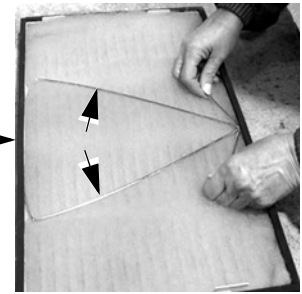

PC00001

6. Install each filter frame to the bonnet on top of the cabinet.

- Carefully align the frame's mounting hooks with the slots in the bonnet. (The hooks should be pointing down.)
- Press down at the top of the filter frame. (The filter frame slides down approximately 3/4 inch).
- Check all around the filter frame for a secure seal to the exhaust box.



PC00012

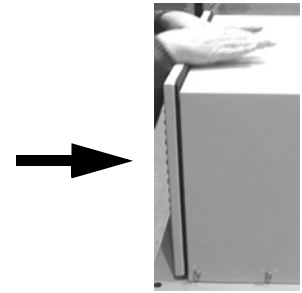

PC00011

Technical Data

Ratings (Supplement to ACS550-01/U1 User's Manual)

Note! The ratings listed below are exceptions to the ratings listed in the ACS550-01/U1 User's Manual.

Ratings, 380...480 Volt Drives

Type Code	Valid up to 40°C (104 °F)				Frame Size
	Normal Use		Heavy-Duty Use		
	I_{2N} A	P_N HP	I_{2hd} A	P_{hd} HP	
-097A-4	96	75	77	60	R5 ¹
-245A-4	245	200	192	150	R7
-316A-4	316	250	240	200	R8
-368A-4	368	300	302	250	R8
-414A-4	414	350	368	300	R8
-486A-4	486	400	414	350	R8
-526A-4	526	450	477	400	R8
-602A-4	602	500	515	450	R8
-645A-4	645	550	590	500	R8

1. For ACS550-PC or -PD, this unit is an R4 drive, in an R5 enclosure.

Input Power Connections (Supplement to ACS550-01/U1 User's Manual)

Fuses

NOTE! Although fuses listed are similar in functional characteristics to fuses listed in the ACS550-01/U1 User's Manual, physical characteristics may differ. Fuses from other manufacturers can be used if they meet the functional characteristics of those in these tables.

Drive input fuses are provided to disconnect the drive from power in the event that a component fails in the drive's power circuitry.

208...240 Volt Fuses

208 ... 240 Volt		Frame Size	Drive Input Fuse Ratings	
HP	Identification ¹		Amps (600V)	Bussmann Type
1	ACS550-PD-04A6-2	R1	15	KTK-R-15
1.5	ACS550-PD-06A6-2	R1	15	KTK-R-15
2	ACS550-PD-07A5-2	R1	15	KTK-R-15
3	ACS550-PD-012A-2	R1	15	KTK-R-15
5	ACS550-PD-017A-2	R1	30	KTK-R-30
7.5	ACS550-PD-024A-2	R2	30	KTK-R-30
10	ACS550-PD-031A-2	R2	50	JJS-50
15	ACS550-PD-046A-2	R3	80	JJS-80
20	ACS550-PD-059A-2	R3	80	JJS-80
25	ACS550-PD-075A-2	R4	100	JJS-100
30	ACS550-PD-088A-2	R4	125	170M1368 ²
40	ACS550-PD-114A-2	R4	160	170M1369 ²
50	ACS550-Px-143A-2	R6	200	170M1370 ²
60	ACS550-Px-178A-2	R6	250	170M1371 ²
75	ACS550-Px-221A-2	R6	315	170M1372 ²
100	ACS550-Px-248A-2	R6	315	170M1372 ²

1. "Px" represents both PC and PD.

2. NEMA 3R enclosed units are provided with fuses as shown in the ACS550-01/U1 User's Manual.

380...480 Volt Fuses

380 ... 480 Volt		Frame Size	Drive Input Fuse Ratings	
HP	Type Code		Amps (600V)	Bussmann Type
1/1.5	ACS550-PD-03A3-4	R1	15	KTK-R-15
2	ACS550-PD-04A1-4	R1	15	KTK-R-15
3	ACS550-PD-06A9-4	R1	15	KTK-R-15
5	ACS550-PD-08A8-4	R1	15	KTK-R-15
7.5	ACS550-PD-012A-4	R1	15	KTK-R-15
10	ACS550-PD-015A-4	R2	30	KTK-R-30
15	ACS550-PD-023A-4	R2	30	KTK-R-30
20	ACS550-PD-031A-4	R3	50	JJS-50
25	ACS550-PD-038A-4	R3	50	JJS-50
30	ACS550-PD-045A-4	R3	100	JJS-100
30	ACS550-PD-044A-4	R4	100	JJS-100
40	ACS550-PD-059A-4	R4	100	JJS-100
50	ACS550-PD-072A-4	R4	100	JJS-100
60	ACS550-PD-078A-4	R4	100	JJS-100
75	ACS550-PD-097A-4	R4/R5	125	170M1368 ³
60	ACS550-PD-077A-4	R5	125	170M1368
75	ACS550-PD-096A-4	R5	125	170M1368 ³
100	ACS550-PD-125A-4	R5	160	170M1369 ³
100	ACS550-PD-124A-4	R6	160	170M1369 ³
125	ACS550-PD-157A-4	R6	200	170M1370 ³
150	ACS550-PD-180A-4	R6	250	170M1371 ³
200	ACS550-PD-245A-4	R7	400	JJS-400
250	ACS550-PD-316A-4	R8	400	JJS-400
300	ACS550-PD-368A-4	R8	400	JJS-400
350	ACS550-PD-414A-4	R8	600	JJS-600
400	ACS550-PD-486A-4	R8	600	JJS-600
450	ACS550-PD-526A-4	R8	800	JJS-800
500	ACS550-PD-602A-4	R8	800	JJS-800
550	ACS550-PD-645A-4	R8	800	JJS-800

1. "Px" represents both PC and PD.

2. R4 drive in an R5 enclosure.

3. NEMA 3R enclosed units are provided with fuses as shown in the ACS550-01/U1 User's Manual.

Fuses, 500...600 Volt, Fuses

500...600 Volt		Frame Size	Drive Input Fuse Ratings	
HP	Identification ¹		Amps (600V)	Bussmann Type
2	ACS550-PD-02A7-6	R2	15	KTK-R-15
3	ACS550-PD-03A9-6	R2	15	KTK-R-15
5	ACS550-PD-06A1-6	R2	15	KTK-R-15
7.5	ACS550-PD-09A0-6	R2	15	KTK-R-15
10	ACS550-PD-011A-6	R2	30	KTK-R-30
15	ACS550-PD-017A-6	R2	30	KTK-R-30
20	ACS550-PD-022A-6	R3	50	JJS-50
25	ACS550-PD-027A-6	R3	50	JJS-50
30	ACS550-PD-032A-6	R4	100	JJS-100
40	ACS550-PD-041A-6	R4	100	JJS-100
50	ACS550-PD-052A-6	R4	100	JJS-100
60	ACS550-PD-062A-6	R4	100	JJS-100
75	ACS550-Px-077A-6	R6	125	170M1368 ²
100	ACS550-Px-099A-6	R6	125	170M1368 ²
125	ACS550-Px-125A-6	R6	160	170M1369 ²
150	ACS550-Px-144A-6	R6	200	170M1370 ²

1. "Px" represents both PC and PD.

2. NEMA 3R enclosed units are provided with fuses as shown in the ACS550-01/U1 User's Manual.

Input Power Cables/ Wiring – R7/R8

NEC	
Based on:	
<ul style="list-style-type: none"> • NEC Table 310-16 for copper wires • 90 °C (194 °F) wire insulation • 40 °C (104 °F) ambient temperature • Not more than three current-carrying conductors in raceway or cable, or earth (directly buried). • Copper cables with concentric copper shield 	
Max Load Current (A)	Cu Wire Size (AWG/kcmil)
345	400 MCM or 2 x 2/0
391	500 MCM or 2 x 3/0
410	2 x 3/0
465	2x4/0
474	2x250
534	2x300
615	2x350
711	2x500

Drive's Power Connection Terminals (Supplement to ACS550-01/U1 User's Manual)

The following tables show maximum wire size and required tightening torque for incoming power, grounding and motor terminals.

208...240 Volt, Terminals

208...240 Volt, Input Disconnect Power Terminal Data							
208...240 Volt		Frame Size	Maximum Wire Size Capacities of Power Terminals				
HP	Type Code ¹		Circuit Breaker	Disconnect Switch	Motor Terminals	Ground Lugs	
1	ACS550-Px-04A6-2	R1	#1/0 62 in-lbs	#8 7 in-lbs	#8 12 in-lbs	#4 35 in-lbs	
1.5	ACS550-Px-06A6-2	R1					
2	ACS550-Px-07A5-2	R1					
3	ACS550-Px-012A-2	R1					
5	ACS550-Px-017A-2	R1					
7.5	ACS550-Px-024A-2	R2					
10	ACS550-Px-031A-2	R2		#1 18 in-lbs	#3 24 in-lbs	#2 50 in-lbs	
15	ACS550-Px-046A-2	R3					
20	ACS550-Px-059A-2	R3					
25	ACS550-Px-075A-2	R4		#1/0 55 in-lbs	#1/0 180 in-lbs		
30	ACS550-Px-088A-2	R4	#1/0 70 in-lbs				
40	ACS550-Px-114A-2	R4	350 MCM 200 in-lbs	350 MCM 200 in-lbs			
50	ACS550-Px-143A-2	R6					
60	ACS550-Px-178A-2	R6	2 x 250 MCM 275 in-lbs	2 x 250 MCM 275 in-lbs	350 MCM 354 in-lbs		3 x #3/0 250 in-lbs
75	ACS550-Px-221A-2	R6					
100	ACS550-Px-248A-2	R6					

1. "Px" represents both PC and PD.

380...480 Volt, Terminals

380...480 Volt, Input Disconnect Power Terminal Data						
380...480 Volt		Frame Size	Maximum Wire Size Capacities of Power Terminals			
HP	Identification ¹		Circuit Breaker	Disconnect Switch	Motor Terminals	Ground Lugs
1/1.5	ACS550-Px-03A3-4	R1	#1/0 62 in-lbs	#8 7 in-lbs	#8 12 in-lbs	#4 35 in-lbs
2	ACS550-Px-04A1-4	R1				
3	ACS550-Px-06A9-4	R1				
5	ACS550-Px-08A8-4	R1				
7.5	ACS550-Px-012A-4	R1				
10	ACS550-Px-015A-4	R2				
15	ACS550-Px-023A-4	R2		#1 18 in-lbs	#3 24 in-lbs	#2 50 in-lbs
20	ACS550-Px-031A-4	R3				
25	ACS550-Px-038A-4	R3				
30	ACS550-Px-045A-4	R3			#1/0 180 in-lbs	
30	ACS550-Px-044A-4	R4				
40	ACS550-Px-059A-4	R4				
50	ACS550-Px-072A-4	R4	350 MCM 200 in-lbs	#1/0 70 in-lbs	3 x #3/0 250 in-lbs	
60	ACS550-Px-078A-4	R4				
75	ACS550-Px-097A-4	R4/ R5 ²				
60	ACS550-Px-077A-4	R5		#2/0 132 in-lbs		
75	ACS550-Px-096A-4	R5				
100	ACS550-Px-125A-4	R5				
100	ACS550-Px-124A-4	R6	350 MCM 200 in-lbs	350 MCM 354 in-lbs		
125	ACS550-Px-157A-4	R6				
150	ACS550-Px-180A-4	R6				
200	ACS550-Px-245A-4	R7	2 x 250 MCM 275 in-lbs	2 x 250 MCM 275 in-lbs	350 MCM 350 in-lbs	
250	ACS550-Px-316A-4	R8				
300	ACS550-Px-368A-4	R8	2 x 500 MCM 275 in-lbs	2 x 500 MCM 275 in-lbs	2 x 500 MCM 500 in-lbs	
350	ACS550-Px-414A-4	R8				
400	ACS550-Px-486A-4	R8				
450	ACS550-Px-526A-4	R8	3 x 400 MCM 375 in-lbs	3 x 400 MCM 375 in-lbs		
500	ACS550-Px-602A-4	R8				
550	ACS550-Px-645A-4	R8				

1. "Px" represents both PC and PD.

2. For ACS550-PC or -PD, this unit is an R4 drive in an R5 enclosure.

500...600 Volt, Terminals

500...600 Volt, Input Disconnect Power Terminal Data							
500...600 Volt		Frame Size	Maximum Wire Size Capacities of Power Terminals				
HP	Type Code ¹		Circuit Breaker	Disconnect Switch	Motor Terminals	Ground Lugs	
2	ACS550-Px-02A7-6	R2	#1/0 62 in-lbs	#8 7 in-lbs	#8 12 in-lbs	#4 35 in-lbs	
3	ACS550-Px-03A9-6	R2					
5	ACS550-Px-06A1-6	R2					
7.5	ACS550-Px-09A0-6	R2					
10	ACS550-Px-011A-6	R2					
15	ACS550-Px-017A-6	R2					
20	ACS550-Px-022A-6	R3		#1 18 in-lbs	#3 24 in-lbs	#2 50 in-lbs	
25	ACS550-Px-027A-6	R3					
30	ACS550-Px-032A-6	R4					
40	ACS550-Px-041A-6	R4					
50	ACS550-Px-052A-6	R4	#1/0 55 in-lbs	#1/0 180 in-lbs			
60	ACS550-Px-062A-6	R4	#1/0 62 in-lbs				
75	ACS550-Px-077A-6	R6	350 MCM 200 in-lbs	#1/0 70 in-lbs	350 MCM 354 in-lbs		3 x #3/0 250 in-lbs
100	ACS550-Px-099A-6	R6					
125	ACS550-Px-125A-6	R6		350 MCM 200 in-lbs			
150	ACS550-Px-144A-6	R6					

1. "Px" represents both PC and PD.

Motor Connections

Motor Connection Specifications – R7/R8

Motor Connection Specifications				
Maximum Motor Cable Length	Frame Size	Max. Motor Cable Length*		
		$f_{sw} = 1 \text{ or } 4 \text{ kHz}$		$f_{sw} = 8 \text{ kHz or } 12 \text{ kHz}$
	R7...R8	300 m	980 ft	Does not apply



* Warning! Using a motor cable longer than specified in the chart above may cause permanent damage to the drive.

Cooling – R7/R8

Cooling Specifications	
Method	Internal fan, flow direction from bottom to top.
Requirement	<ul style="list-style-type: none"> R7/R8: Free space in front of enclosure: 152 mm (6 in). R7/R8: Free space above enclosure: None required for cooling. R7/R8: Free space at sides of enclosure: None required for cooling. R7/R8: Also see “Additional Free Space Recommendations” on page 39.

Air Flow, 380...480 Volt Drives – R7/R8

The following table lists heat loss and air flow data for 380...480 Volt drives.

Drive		Heat Loss		Air Flow	
ACS550-xx-	Frame Size	W	BTU/Hr	m ³ /h	ft ³ /min
-245A-4	R7	3850	13000	300	540
-316A-4	R8	5300	18000	700	1220
-368A-4	R8	6850	23000	700	1220
-414A-4	R8	7000	24000	700	1220
-486A-4	R8	7600	26000	700	1220
-526A-4	R8	7800	27000	700	1220
-602A-4	R8	8100	28000	700	1220
-645A-4	R8	9100	31000	700	1220

Dimensions and Weights (Supplement to ACS550-01/U1 User’s Manual)

Mounting Dimensions

NEMA 1 & 12, R1...R6 Mounting Dimensions)

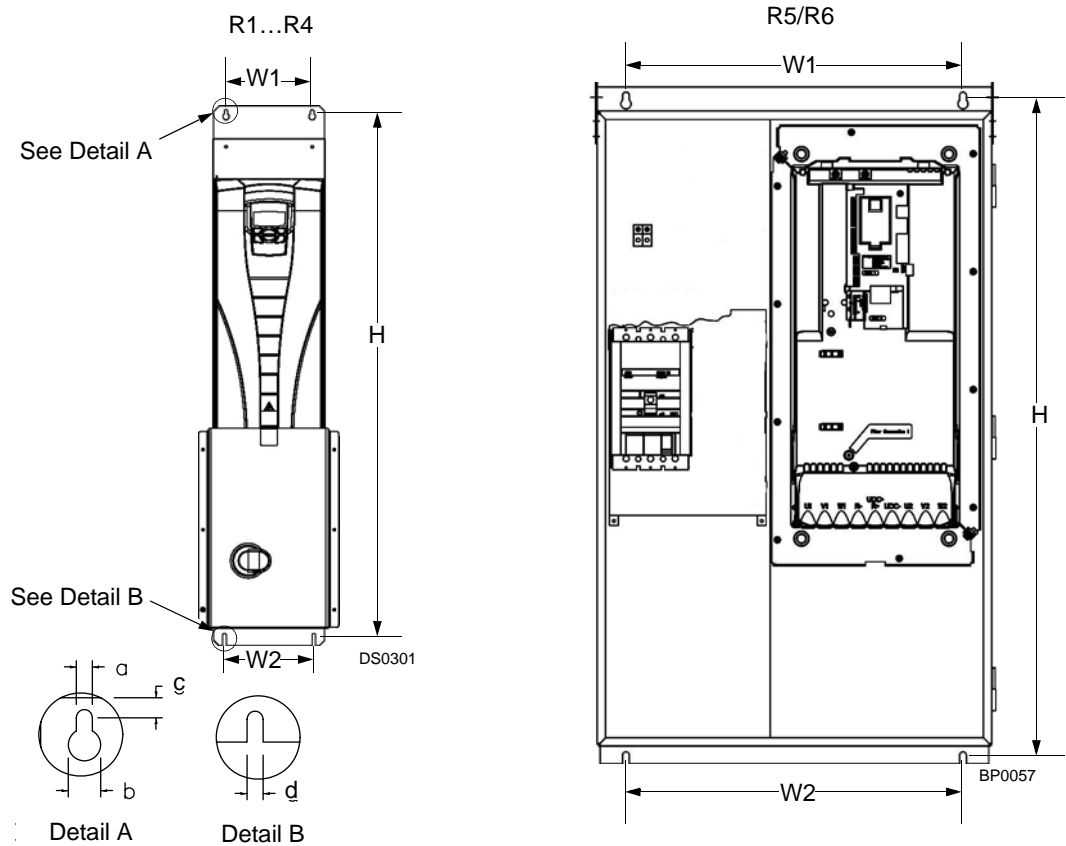

NEMA 1 and NEMA 12 – Mounting Dimensions for each Frame Size												
Ref.	R1		R2		R3		R4		R5		R6	
	mm	in	mm	in	mm	in	mm	in	mm	in	mm	in
W1*	98	3.9	98	3.9	160	6.3	160	6.3	600	23.6	600	23.6
W2*	98	3.9	98	3.9	160	6.3	160	6.3	600	23.6	600	23.6
H*	712	28.0	812	32.0	983	38.7	1117	44.0	1175	46.3	1175	46.3
a	5.5	0.2	5.5	0.2	6.5	0.25	6.5	0.25	6.5	0.25	9.0	0.35
b	10.0	0.4	10.0	0.4	13.0	0.5	13.0	0.5	14.0	0.55	14.0	0.55
c	5.5	0.2	5.5	0.2	8.0	0.3	8.0	0.3	8.5	0.3	8.5	0.3
d	5.5	0.2	5.5	0.2	6.5	0.25	6.5	0.25	6.5	0.25	9.0	0.35
Mounting Hardware												
	M6	1/4	M6	1/4	M6	1/4	M6	1/4	M8	5/16	M8	5/16

* Measurements are center to center.

NEMA 3R, R1...R6 Mounting Dimensions

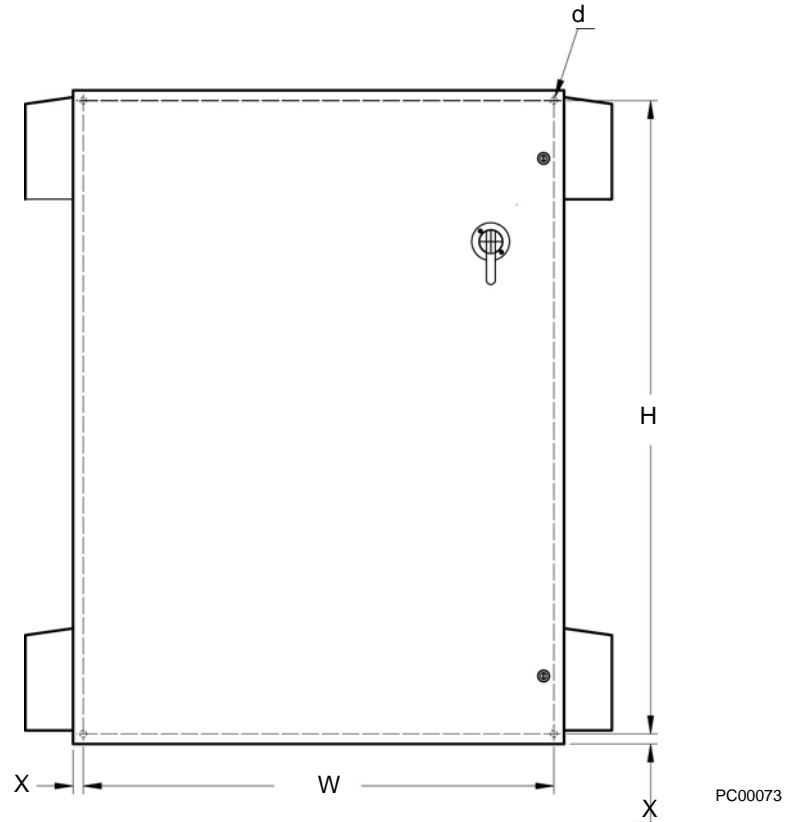

NEMA 3R – Mounting Dimensions for each Frame Size												
Ref.	R1		R2		R3		R4		R5		R6	
	mm	in	mm	in	mm	in	mm	in	mm	in	mm	in
H	572	22.5	572	22.5	724	28.5	876	34.5	1181	46.5	1181	46.5
W	419	16.5	419	16.5	572	22.5	724	28.5	876	34.5	876	34.5
d	12.7	0.5	12.7	0.5	12.7	0.5	12.7	0.5	12.7	0.5	12.7	0.5
X	19.0	0.75	19.0	0.75	19	0.75	19	0.75	19	0.75	19	0.75
Mounting Hardware												
	M6	1/4	M6	1/4	M6	1/4	M6	1/4	M8	5/16	M8	5/16

* Measurements are center to center.

NEMA 1 & 12, R7...R8 Mounting Dimensions

NEMA 1 and NEMA 12 – Dimensions for each Frame Size			
Ref.	R7 & R8		Top View
	mm	in	
W	806	31.7	
D	659	25.9	
a	675	26.6	
b	474.5	18.7	
c	61	2.4	
d	65.5	2.6	
Mounting Hardware			
	11 mm	13/32	

Weights

The following table lists typical maximum weights for each frame size. Variations within each frame size (due to components associated with voltage/current ratings, and options) are minor.

Enclosure	Weight															
	R1		R2		R3		R4		R5		R6		R7		R8	
	kg	lb.	kg	lb.	kg	lb.	kg	lb.	kg	lb.	kg	lb.	kg	lb.	kg	lb.
NEMA 1	13	28	17	37	45	100	55	121	121	266	163	360	230	506	360	793
NEMA 12	15	33	19	42	47	103	57	125	123	271	166	375	250	551	380	837
NEMA 3R	34	75	37	81	61	135	92	203	132	291	167	368	--	--	--	--

Outside Dimensions

The outside dimensions for input disconnect enclosures depend on the frame size and the enclosure type, as illustrated below.

NEMA 1, R1...R4 Outside Dimensions

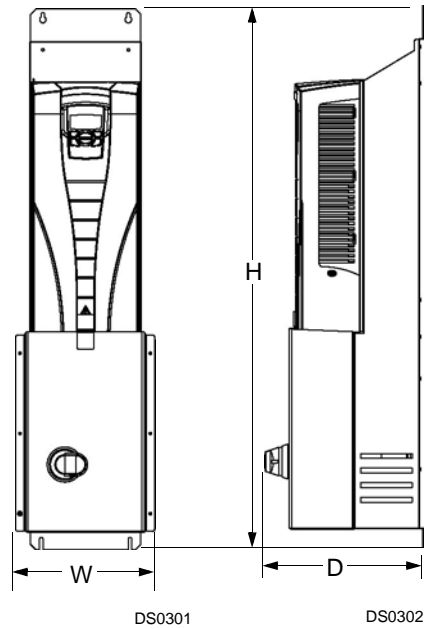

Input Disconnect, NEMA 1, R1...R4								
Dimensions Ref.	R1		R2		R3		R4	
	mm	in.	mm	in.	mm	in.	mm	in.
W	198	7.8	198	7.8	260	10.2	260	10.2
H	729	28.7	829	32.6	1013	39.9	1147	45.2
D	283	11.2	295	11.6	304	11.9	332	13.1

NEMA 12, R1...R4 Outside Dimensions

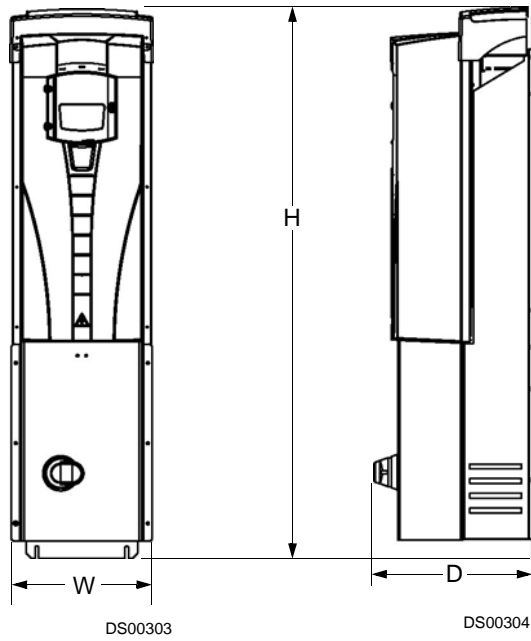

Input Disconnect, NEMA 12, R1...R4								
Dimensions Ref.	R1		R2		R3		R4	
	mm	in.	mm	in.	mm	in.	mm	in.
W	222	8.7	222	8.7	267	10.5	267	10.5
H	744	29.3	844	33.2	1030	40.6	1163	45.8
D	283	11.2	295	11.6	304	11.9	332	13.1

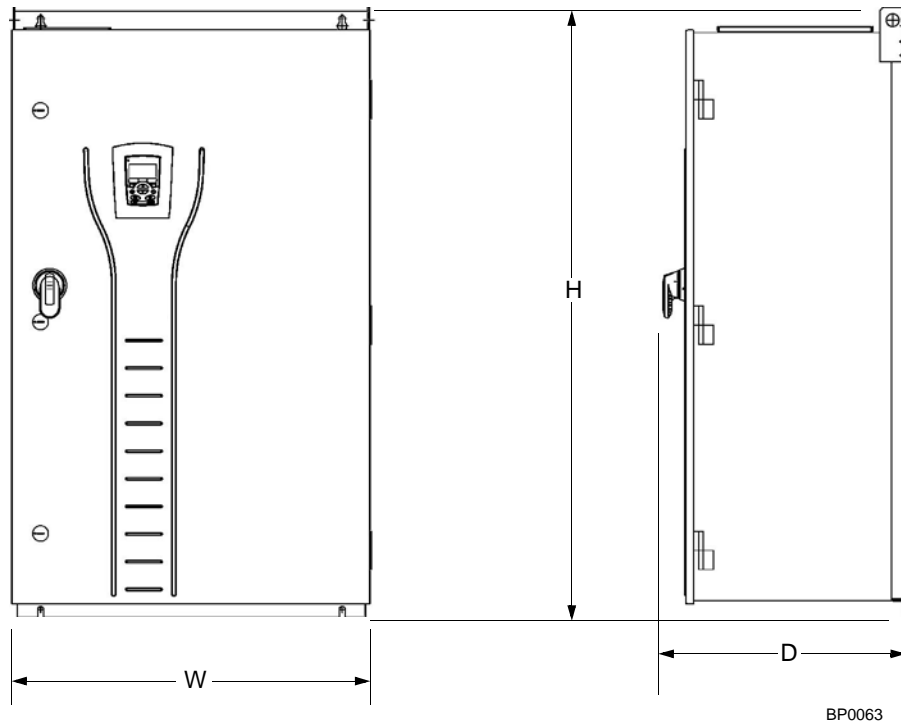
NEMA 1, R5, R6 Outside Dimensions

Input Disconnect, NEMA 1, R5, R6				
Dimensions Ref.	R5		R6	
	mm	in.	mm	in.
W	713	28.1	713	28.1
H	1212	47.7	1212	47.7
D	484	19.1	484	19.1

NEMA 12, R5, R6 Outside Dimensions

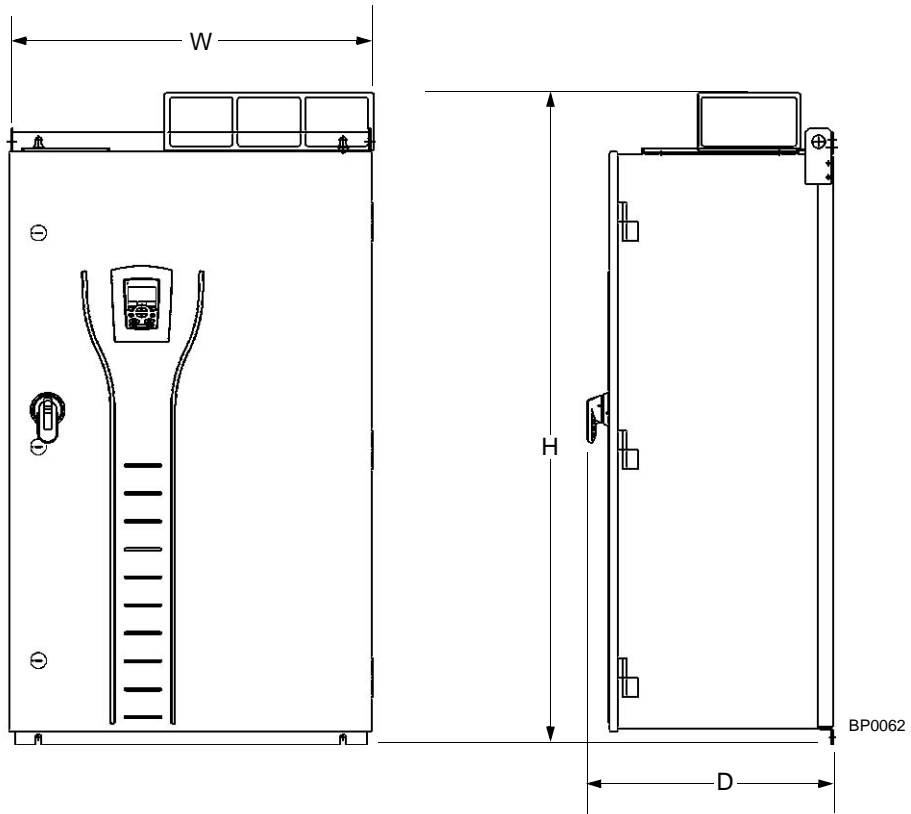

Input Disconnect, NEMA 12, R5, R6				
Dimensions Ref.	R5		R6	
	mm	in.	mm	in.
W	734	28.9	734	28.9
H	1371	54.0	1371	54.0
D	484	19.1	484	19.1

NEMA 3R, R1...R6 Outside Dimensions

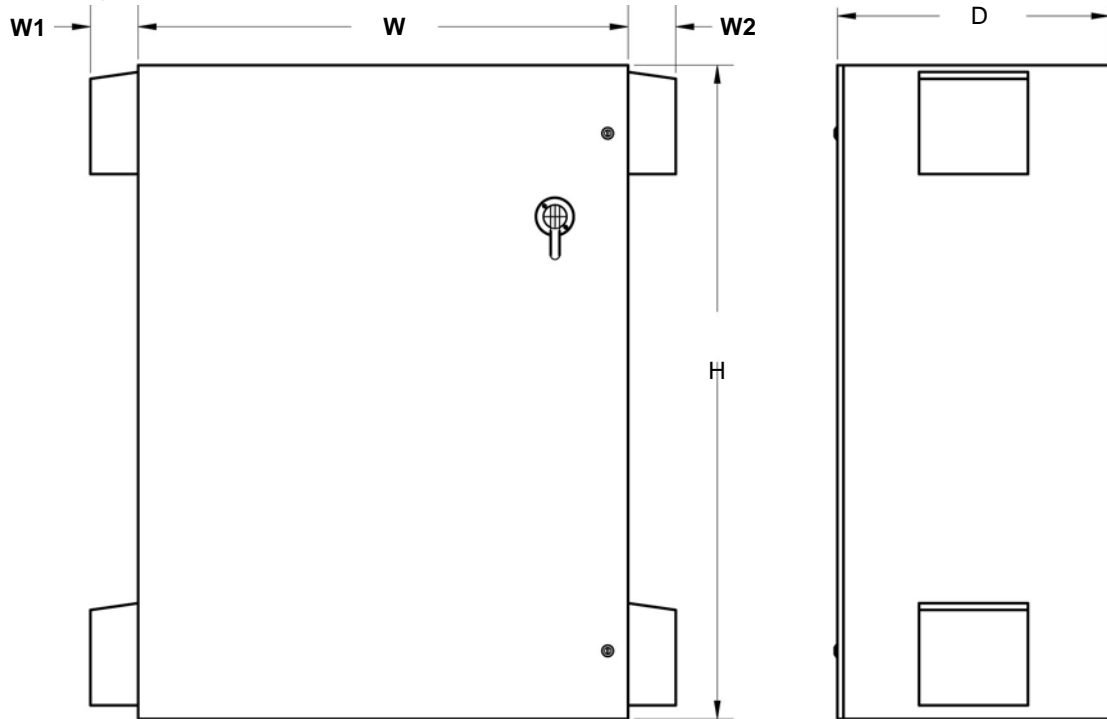

PC00075

Input Disconnect, NEMA 3R, R1...R6												
Dimensions Ref.	R1		R2		R3		R4		R5		R6	
	mm	in.	mm	in.	mm	in.	mm	in.	mm	in.	mm	in.
H	610	24	610	24	762	30	914	36	1219	48	1219	48
W	457	18	457	18	610	24	762	30	914	36	914	36
D	305	12	305	12	305	12	305	12	508	20	508	20
W1	89	3.5	89	3.5	89	3.5	89	3.5	89	3.5	89	3.5
W2	--	--	--	--	--	--	89	3.5	89	3.5	89	3.5

NEMA 1 and NEMA 12, R7...R8 Outside Dimensions

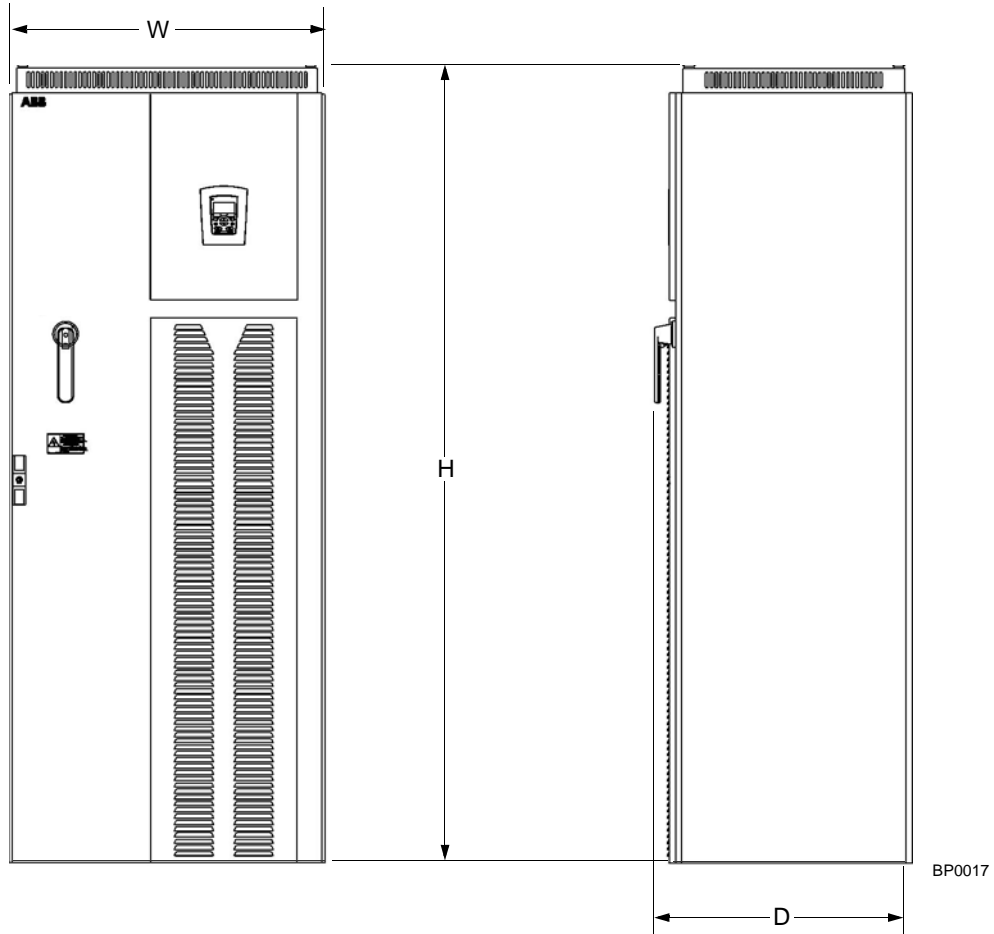

Outside Dimensions by Frame Size					
Enclosure	Ref.	R7		R8	
		mm	in	mm	in
NEMA 1	W	806	31.7	806	31.7
	H	2125	83.7	2125	83.7
	D	659	25.9	659	25.9
NEMA 12	W	806	31.7	806	31.7
	H	2377	93.6	2377	93.6
	D	659	25.9	659	25.9



Additional Free Space Recommendations

In addition to the free space requirements for cooling (“Cooling - R7/R8”), allow:

- 800 mm (31.5 in) in front of R7/R8 enclosures – room for the cabinet door to swing open.
- 305 mm (12 in) above R7/R8, IP54 / UL Type 12 enclosures – room for fan replacement.

Applicable Standards

Drive compliance with the following standards is identified by the standards “marks” on the type code label.

Mark	Applicable Standards	
	UL 508C and C22.2 No. 14	UL Standard for Safety, Power Conversion Equipment, second edition and CSA Standard for Industrial Control Equipment
	UL 508A	UL Standard for Safety, Industrial Control Panels
	C22.2 No. 14	CSA Standard for Industrial Control Equipment

Compliance is valid with the following provisions:

- The motor and control cables are chosen as specified in this manual.
- The installation rules of this manual are followed.

motor cable	
max. length	30

N

NEMA 1	
code	8
NEMA 12	
code	8
NEMA 3R	
code	8

R

ratings	22
remove cover	10

S

safety	1
specifications	
cooling	30
motor connections	30
standards	40
C22.2 No. 14	40
UL 508C	40

T

terminals	
power, wire sizes	27
type code	8

V

voltage	
rating code	8

W

warning	
automatic start up	1
dangerous voltages	1
listing	1
parallel control connections	1
qualified installer	1
weight	
drive	33
wiring	
connection diagrams, floor mounted	13
connection diagrams, wall mounted	12
line input installation	14
overview	12
requirements	11



ABB Oy
AC Drives
P.O. Box 184
FIN-00381 HELSINKI
FINLAND
Telephone +358 10 22 11
Telefax +358 10 22 22681
Internet <http://www.abb.com>

ABB Inc.
Automation Technologies
Drives & Machines
16250 West Glendale Drive
New Berlin, WI 53151
USA
Telephone +1 262 785-3200
+1 800 HELP-365
Telefax +1 262 780-5135
Internet www.abb-drives.com

3AJUA0000012131 REV B / EN
EFFECTIVE: 8/1/2006
SUPERSEDES: 12/30/2005