

1"-4" Combination Air Valve

(Single Housing Type)

Operation, Maintenance and Installation Manual

INTRODUCTION	1
RECEIVING AND STORAGE	1
DESCRIPTION OF OPERATION	1
INSTALLATION	2
VALVE CONSTRUCTION	3
MAINTENANCE	4
TROUBLESHOOTING	4
DISASSEMBLY	4
REASSEMBLY	5
PARTS AND SERVICE	5
WARRANTY	6



VAL-MATIC VALVE AND MANUFACTURING CORP.

905 RIVERSIDE DRIVE ■ ELMHURST, IL 60126
PHONE (630)941-7600 ■ FAX (630)941-8042

VAL-MATIC'S 1"-4" COMBINATION AIR VALVE OPERATION, MAINTENANCE AND INSTALLATION

INTRODUCTION

This manual will provide you with the information to properly install and maintain the valve to ensure a long service life. The valve has been designed with stainless steel trim* to give years of trouble-free operation. The Combination Air Valve is typically mounted at the high points in a piping system and performs the functions of both an air release valve and an air/vacuum valve.

The Combination Air Valve automatically vents air which accumulates at high points in a system during its operation. The valve will also exhaust and admit large quantities (volumes) of air during filling or draining operations and after emergency conditions such as a power failure. Both the air release and air/vacuum functions are needed to maintain pipeline efficiency while providing protection from adverse pressure conditions.

Note: This valve is not intended for fluids containing suspended solids such as wastewater. For wastewater and other high turbidity applications, use Val-Matic Series 800 Wastewater Combination Air Valves.

CAUTION: This valve is not intended for fuel service or fluids containing suspended solids.

The valve is a float-operated, resilient-seated valve designed to handle clean fluids. The Maximum Working Pressure and Model No. are stamped on the nameplate for reference.

*bronze trim provided when specified

RECEIVING AND STORAGE

Inspect valves upon receipt for damage in shipment. Handle all valves carefully without dropping. Valves should remain boxed, clean and dry until installed to prevent weather related damage. For long term storage greater than six months, the valve must remain in the box and stored indoors. Do not expose valve to sunlight or ozone for any extended period.

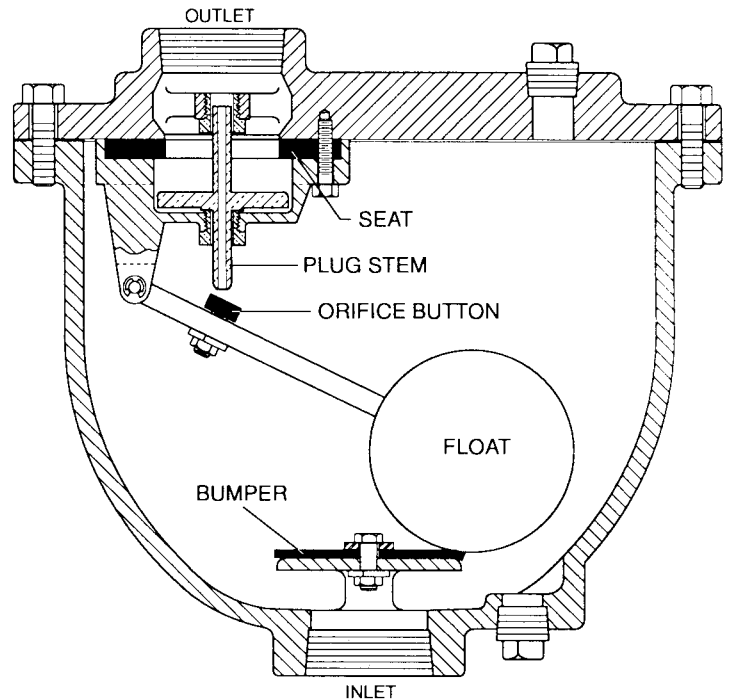

FIGURE 1. 1"-4" COMBINATION AIR VALVE

DESCRIPTION OF OPERATION

The Combination Air Valve is fully automatic and designed to continuously remove air accumulating at the high points in a piping system. It also will exhaust and admit air during filling and draining of the pipeline or tank. The valve, as shipped, is a normally open valve and has three functions.

1. During system start-up, the open valve will exhaust large quantities of air until fluid enters the valve. The float will then rise and press the orifice button, located on the float arm, against the plug stem and raise the plug. Pressure within the valve body will force the plug upward tightly against the seat. See Figure 2.

DESCRIPTION OF OPERATION (Cont'd)

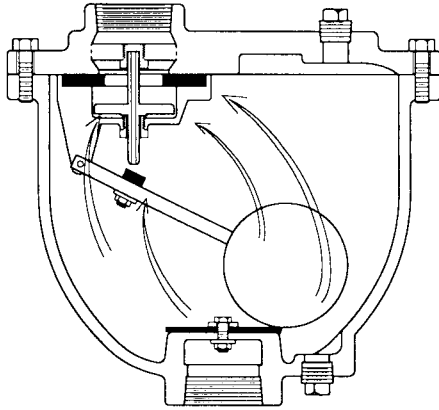

FIGURE 2. Air Exhausted During Pipeline Fill

2. As air accumulates in the piping system and enters the valve, the float drops and the orifice button breaks contact with the plug stem. Accumulated air will vent through the plug stem. As the air is vented, the float raises once again and closes the plug stem orifice. See Figure 3.

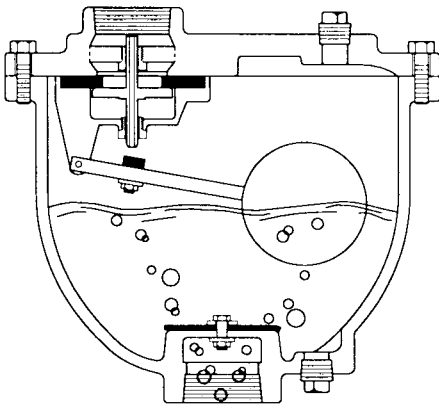

FIGURE 3. Accumulated Air Continuously Released

3. When the system is drained, the plug will reopen allowing air to rapidly re-enter the piping system. See Figure 4.

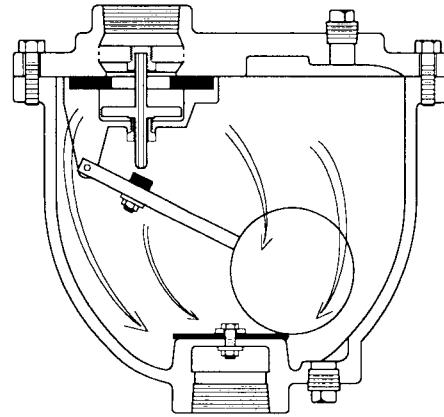

FIGURE 4. Air Enters During Pipeline Draining

At other times the valve is closed and under pressure as shown in Figure 5.

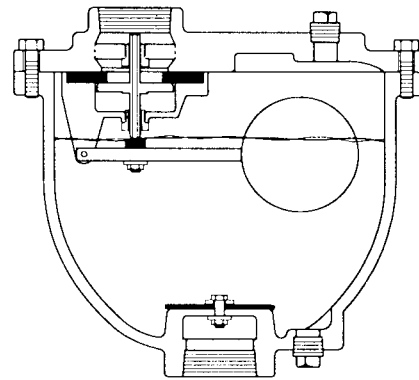

FIGURE 5. Pipeline Under Normal Pressure

INSTALLATION

The installation of the valve is important for its proper operation. Valves must be installed at the system high points in the vertical position with the inlet down. For pipeline service, a vault with freeze protection, adequate screened venting, and drainage should be provided. During closure, some fluid discharge will occur so vent lines should extend to an open drain area in plant service. A shut-off valve should be installed below the valve in the event servicing is required.

CAUTION: Install valve with "INLET" port down or leakage will occur.

VALVE CONSTRUCTION

The standard Combination Air Valve body and cover are cast iron. See the specific Materials List submitted for the order if other than standard cast iron construction. The internal metal components are brass or stainless steel. The orifice button and seat are resilient Buna-N. The general details of construction are illustrated in Figure 6. The body (1) is threaded for connection to the pipeline. The seat (4) is retained by a baffle (3) and the cover (2). The adjustable orifice button (11) has a threaded post for attachment to the float arm (10).

ITEM	DESCRIPTION	MATERIAL
1	Body	Cast Iron
2	Cover	Cast Iron
3	Baffle	Cast Iron
4	Seat*	Buna-N
5	Float*	Stainless Steel
6	Gasket*	Non-Asbestos
7	Cover Bolt	Alloy Steel
8	Retaining Screw*	Stainless Steel
9	Guide Bushing*	Stainless Steel
10	Float Arm*	Stainless Steel
11	Orifice Button*	Buna-N
12	Pivot Pin*	Stainless Steel
13	Retaining Ring*	Stainless Steel
14	Pipe Plug	Steel
15	Cushion*	Buna-N
16	Plug*	Stainless Steel
17	Float Retainer*	Stainless Steel
18	Lock Nut*	Stainless Steel
29	Cushion Retainer*	Stainless Steel
30	Washer*	Stainless Steel
34	Lock Washer*	Stainless Steel

*RECOMMENDED REPAIR PART KIT

TABLE 1. COMBINATION AIR VALVE PARTS LIST

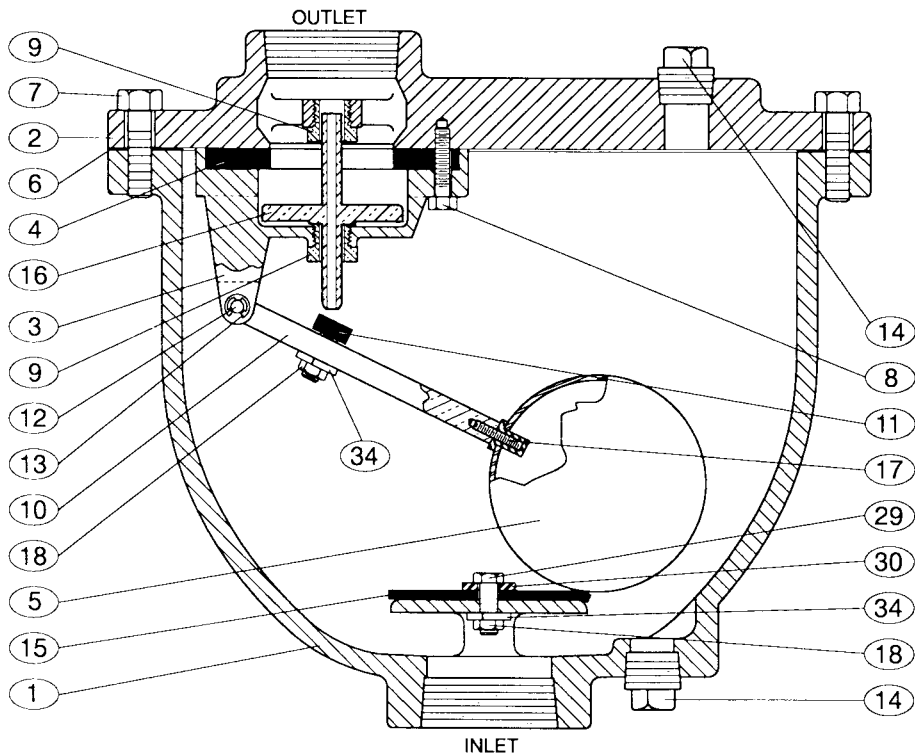

FIGURE 6. 1"-4" COMBINATION AIR VALVE

MAINTENANCE

The Combination Air Valve requires no scheduled lubrication or maintenance.

INSPECTION: Periodic inspection to verify operation can be performed. A manual drain valve can be installed in the lower drain plug to perform this operation as shown in Figure 7.

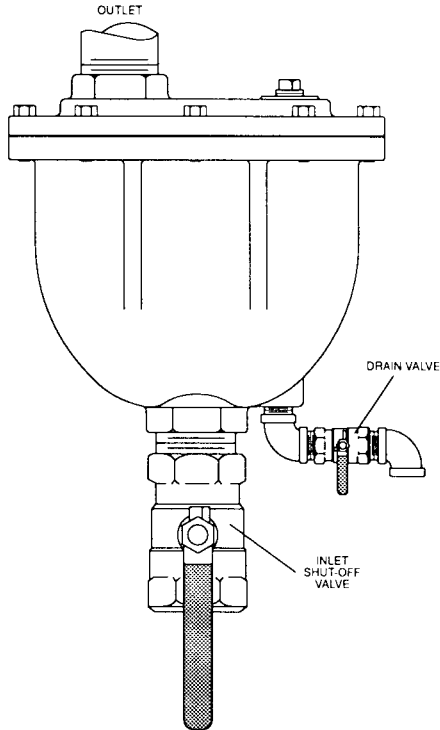

FIGURE 7. INSPECTION PIPING

1. With the inlet shut-off valve open, partially open the drain valve until flow can be heard. If the air valve is working properly, water should be exhausted from the drain valve. If air is exhausted, follow steps 2-6.
2. Close the inlet shut-off valve.
3. Slowly open the drain valve to allow the fluid in the valve to drain. If draining is difficult, the valve may be clogged (valve requires service).
4. Close the drain valve.
5. Slowly open the inlet shut-off valve to fill the valve with water. Observe the seating action and verify that the valve closes without leakage.

6. If leakage occurs, the valve should be removed and inspected for wear or possible damage from foreign matter.

TROUBLESHOOTING

Several problems and solutions are presented below to assist you in troubleshooting the valve assembly in an efficient manner.

- **Leakage at Bottom Connection:** Tighten valve threaded connection. If leak persists, remove valve and seal threads with pipe sealant or tape.
- **Leakage at Cover:** Tighten bolts per Table 2, replace gasket.
- **Valve Leaks when Closed:** Flush valve to remove debris. Disassemble and inspect seat, orifice button and float. NOTE: Many floats contain sand for weight but if water is detected, replace float.
- **Valve not Venting Air:** Check that operating pressure does not exceed Working Pressure on nameplate. Perform inspection steps 2-6 and disassemble valve if problem persists.

DISASSEMBLY

The valve can be disassembled without removing it from the pipeline. Or for convenience, the valve can be removed from the line. All work on the valve should be performed by a skilled mechanic with proper tools. No special tools are required.

WARNING: The valve must be drained before removing the cover or pressure may be released causing injury.

1. Close inlet shut-off valve. Slowly open drain valve or remove drain plug. Remove the cover bolts (7) on the top cover.
2. Pry cover (2) loose and lift off valve body.
3. Remove the retainer ring (13) and pivot pin (12) that pass through the float arm (10).
4. To remove baffle (3), remove fasteners (8).
5. Remove locknut (18) and orifice button (11).

DISASSEMBLY (Cont'd)

6. Clean and inspect parts. Note: some floats contain sand for extra weight; if water is detected, replace float. Replace worn parts as necessary and lubricate parts with FDA grease such as Lubriko #CW-606. Remove all foreign matter from body and cover.

REASSEMBLY

All parts must be cleaned and gasket surfaces should be cleaned with a stiff wire brush in the direction of the serrations or machine marks. Worn parts, gaskets and seals should be replaced during reassembly. Refer to Figure 6 on page 3.

1. Apply Loctite Primer and 680 Compound to float threads and assemble to arm (10). Apply Loctite to bushing (9) and install into baffle (3).
2. Lay cover on flat surface with outlet faced down. Lay seat (4), plug (16), and baffle (3) over cover with screws (8) loosely engaged. Verify that plug moves up and down freely. Lift plug and drop into seat until baffle is positioned and plug contacts seat smoothly; tighten screws to 5-10 ft-lbs.
3. Screw new orifice button (11) into arm (10) with lockwasher (34) and locknut (18). Do not tighten nut at this time.
4. Connect arm (10) to baffle (3) with pivot pin (12) and retaining rings (13).
5. Adjust orifice button so that when it is in light contact with the plug stem, the arm (10) slopes away from the cover about 1/16". Lock orifice button with lock nut (18).
6. Install new cushion (15) with fastener items (29, 30, 34, & 18).
7. Lay new cover gasket on clean surface and apply a gasket compound such as Permatex #80065 to both surfaces. Assemble gasket (6) and cover (2) over bolt holes in body (1).
8. Insert lubricated bolts (7) and tighten to the torques listed in Table 2.

9. Place valve back in service. Refer to the Installation instructions on page 2. Slowly open inlet isolation valve.

<u>BOLT SIZE</u>	<u>TORQUE (FT-LBS)</u>
7/16"-14	30
1/2"-13	45
5/8"-11	93
3/4"-10	150
7/8"-9	200

TABLE 2. VALVE COVER BOLT TORQUES

PARTS AND SERVICE

Parts and service are available from your local representative or the factory. Make note of the valve Model No. and Working Pressure located on the valve nameplate and contact:

Val-Matic Valve and Mfg. Corp.
905 Riverside Drive
Elmhurst, IL 60126
PH: 630/941-7600
FAX: 630/941-8042

A sales representative will quote prices for parts or arrange for service as needed.

LIMITED WARRANTY

All products are warranted to be free of defects in material and workmanship for a period of one year from the date of shipment, subject to the limitations below.

If the purchaser believes a product is defective, the purchaser shall: (a) Notify the manufacturer, state the alleged defect and request permission to return the product; (b) if permission is given, return the product with transportation prepaid. If the product is accepted for return and found to be defective, the manufacturer will, at his discretion, either repair or replace the product, f.o.b. factory, within 60 days of receipt, or refund the purchase price. Other than to repair, replace or refund as described above, purchaser agrees that manufacturer shall not be liable for any loss, costs, expenses or damages of any kind arising out of the product, its use, installation or replacement, labeling, instructions, information or technical data of any kind, description of product use, sample or model, warnings or lack of any of the foregoing. NO OTHER WARRANTIES, WRITTEN OR ORAL, EXPRESS OR IMPLIED, INCLUDING THE WARRANTIES OF FITNESS FOR A PARTICULAR PURPOSE AND MERCHANTABILITY, ARE MADE OR AUTHORIZED. NO AFFIRMATION OF FACT, PROMISE, DESCRIPTION OF PRODUCT OF USE OR SAMPLE OR MODEL SHALL CREATE ANY WARRANTY FROM MANUFACTURER, UNLESS SIGNED BY THE PRESIDENT OF THE MANUFACTURER. These products are not manufactured, sold or intended for personal, family or household purposes.



VAL-MATIC VALVE AND MANUFACTURING CORP.

905 RIVERSIDE DRIVE ■ ELMHURST, IL 60126
PHONE (630)941-7600 ■ FAX (630)941-8042