

# Air Release Valve

## (Simple Lever Type)

### Operation, Maintenance and Installation Manual

|                                |   |
|--------------------------------|---|
| INTRODUCTION .....             | 1 |
| RECEIVING AND STORAGE .....    | 1 |
| DESCRIPTION OF OPERATION ..... | 1 |
| INSTALLATION .....             | 2 |
| VALVE CONSTRUCTION .....       | 2 |
| MAINTENANCE .....              | 3 |
| TROUBLESHOOTING .....          | 3 |
| DISASSEMBLY .....              | 3 |
| REASSEMBLY .....               | 4 |
| PARTS AND SERVICE .....        | 4 |
| WARRANTY .....                 | 5 |



VAL-MATIC® VALVE AND MANUFACTURING CORP.

905 RIVERSIDE DRIVE ELMHURST, IL. 60126  
TEL. 630/941-7600 FAX. 630/941-8042

# VAL-MATIC'S AIR RELEASE VALVE (Simple Lever Type) OPERATION, MAINTENANCE AND INSTALLATION

## INTRODUCTION

This manual will provide you with the information to properly install and maintain the valve to ensure a long service life. The Air Release Valve has been designed with stainless steel trim to give years of trouble-free operation. The Air Release Valve is typically mounted at the high points in a piping system to automatically remove pockets of air as they accumulate. The valve can also be used to slowly release air in tanks and pump casings.

Note: This valve is not intended for fluids containing suspended solids such as wastewater. For wastewater and other high turbidity applications, use Val-Matic Series 48 & 49 Sewage Air Release Valves.

**CAUTION:** This valve is not intended for fuel service or fluids containing suspended solids.

The valve is a float-operated, resilient-seated valve designed to handle clean fluids. The Maximum Working Pressure and Model No. are stamped on the nameplate for reference.

## RECEIVING AND STORAGE

Inspect valves upon receipt for damage in shipment. Handle all valves carefully without dropping. Valves should remain boxed, clean and dry until installed to prevent weather related damage. For long term storage greater than six months, the valve must remain in the box and stored indoors. Do not expose valve to sunlight or ozone for any extended period.

## DESCRIPTION OF OPERATION

The Air Release Valve is designed to automatically remove air pockets at the high points in a piping system. The valve, as shipped, is a normally open valve and will slowly vent air through the top orifice. As fluid enters the valve, the float will rise, closing the orifice. As air accumulates in the piping system and enters the valve, the float drops allowing the venting orifice to open.

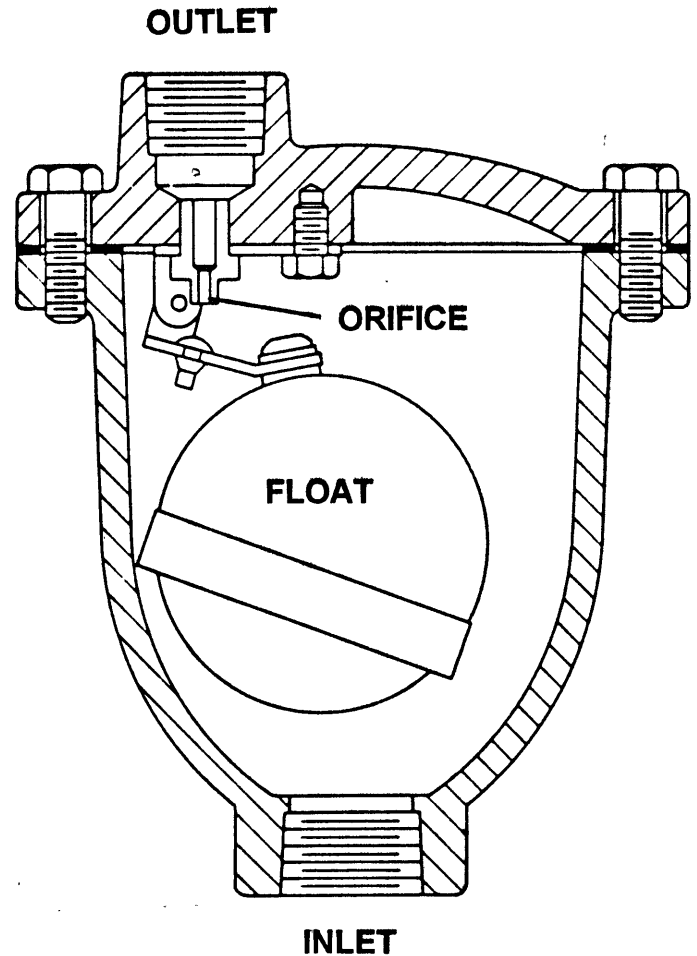

FIGURE 1. Simple Lever AIR RELEASE VALVE

The lever mechanism provides mechanical advantage for the float. During system operation, the pipeline pressure exerts a strong upward force on the sealing component, the orifice button. The lever mechanism magnifies the weight of the float so that the orifice will open under high pipeline pressures. Additional ports are provided for flushing, testing and draining purposes.

## INSTALLATION

The installation of the valve is important for its proper operation. Valves must be installed at the system high points in the vertical position with the inlet down. For pipeline service, a vault with freeze protection, adequate screened venting, and drainage should be provided. During closure, some fluid discharge will occur so vent lines should extend to an open drain area in plant service. A shut-off valve should be installed below the valve in the event servicing is required.

**CAUTION:** Install valve with "INLET" port down or leakage will occur.

## VALVE CONSTRUCTION

The standard Air Release Valve body and cover are cast iron. See the specific Materials List submitted for the order if other than standard cast iron construction. All internal components are stainless steel with the exception of the orifice button which is resilient. The general details of construction are illustrated in Figure 2. The body (1) is threaded for connection to the pipeline. The seat (4) is threaded into the cast cover (2).

| ITEM | DESCRIPTION     | MATERIAL        |
|------|-----------------|-----------------|
| 1    | Body            | Cast Iron       |
| 2    | Cover           | Cast Iron       |
| 3    | Lever Frame*    | Stainless Steel |
| 4    | Seat*           | Stainless Steel |
| 5    | Float*          | Stainless Steel |
| 6    | Gasket*         | Non-Asbestos    |
| 7    | Cover Bolt      | Alloy Steel     |
| 10   | Float Arm*      | Stainless Steel |
| 11   | Orifice Button* | Buna-N          |
| 12   | Pivot Pin*      | Stainless Steel |
| 13   | Pin Retainer*   | Stainless Steel |
| 14   | Pipe Plug       | Iron            |
| 17   | Float Retainer* | Stainless Steel |
| 21   | Locator*        | Stainless Steel |
| 34   | Lock Washer*    | Stainless Steel |

\*RECOMMENDED REPAIR PART KIT

TABLE 1. AIR RELEASE VALVE PARTS LIST

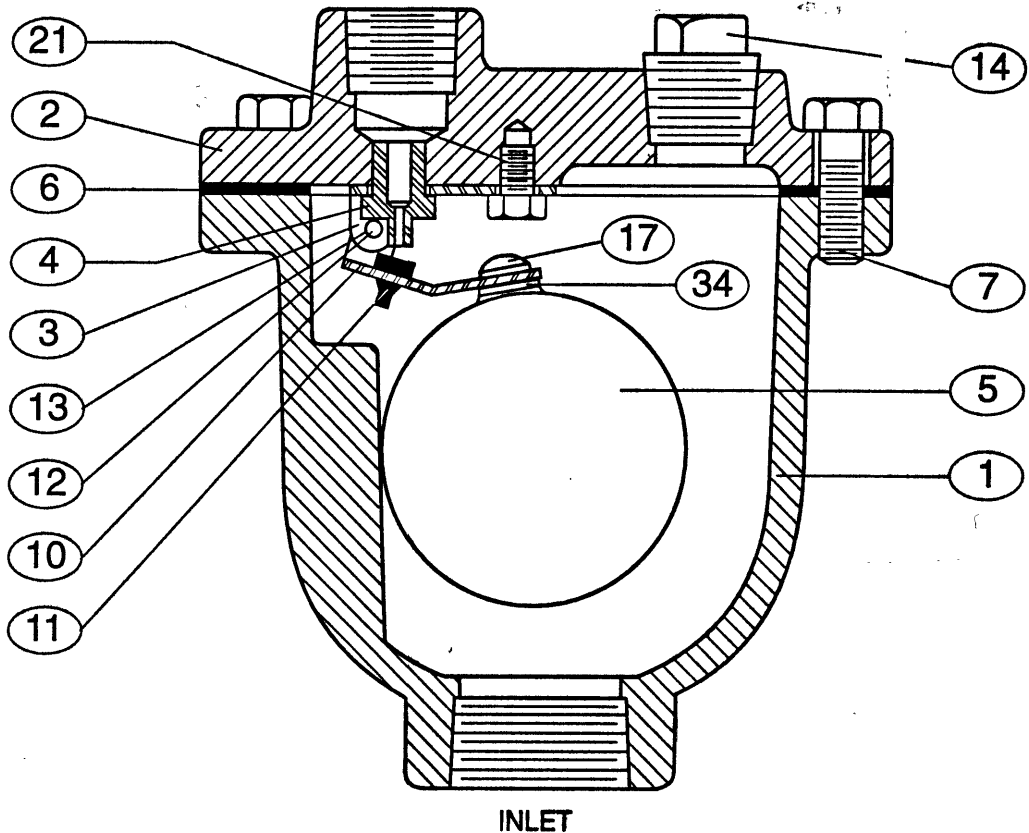

FIGURE 2. SIMPLE LEVER AIR RELEASE VALVE

## MAINTENANCE

The Air Release Valve requires no scheduled lubrication or maintenance.

**INSPECTION:** Periodic inspection to verify operation can be performed. A manual drain valve can be installed in the lower drain plug to perform this operation as shown in Figure 3.

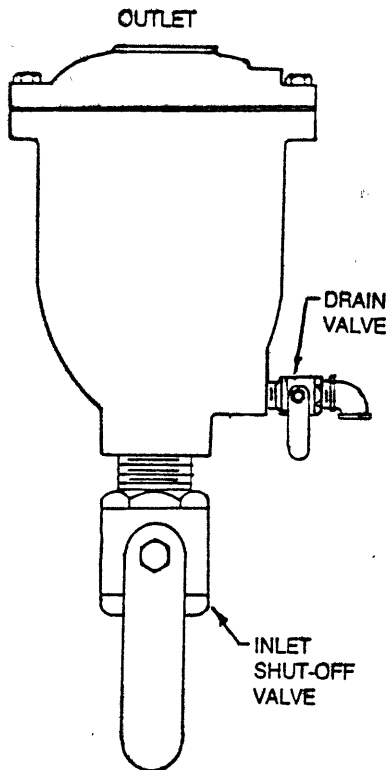

FIGURE 3. INSPECTION PIPING

1. With the inlet shut-off valve open, partially open the drain valve until flow can be heard. If the Air Valve is working properly, water should be exhausted from the drain valve. If air is exhausted, follow steps 2-6.
2. Close the inlet shut-off valve.
3. Slowly open the drain valve to allow the fluid in the valve to drain. If draining is difficult, the orifice may be clogged (valve requires service).
4. Close the drain valve.
5. Slowly crack open the inlet shut-off valve to fill the valve with water. Observe the seating action and verify that the valve closes without leakage.

6. If leakage occurs, the valve should be removed and inspected for wear or possible damage from foreign matter.

## TROUBLESHOOTING

Several problems and solutions are presented below to assist you in troubleshooting the valve assembly in an efficient manner.

● **Leakage at Bottom Connection:** Tighten valve threaded connection. If leak persists, remove valve and seal threads with Teflon\* sealant.

● **Leakage at Cover:** Tighten bolts per Table 2, replace gasket.

● **Valve Leaks when Closed:** Flush valve to remove debris. Disassemble and inspect seat, orifice button, and float. NOTE: Many floats contain sand for weight but if water is detected, replace float.

● **Valve not Venting Air:** Check that operating pressure does not exceed Working Pressure on nameplate. Perform inspection steps 2-6 and disassemble valve if problem persists.

\*Du Pont registered trademark.

## DISASSEMBLY

The valve can be disassembled without removing it from the pipeline. Or for convenience, the valve can be removed from the line. All work on the valve should be performed by a skilled mechanic with proper tools. No special tools are required.

**WARNING:** The valve must be drained before removing the cover or pressure may be released causing injury.

1. Close inlet shut-off valve. Open drain valve or remove drain plug. Remove the cover bolts (7) on the top cover.
2. Pry cover (2) loose and lift off valve body.
3. Remove the 2 retainer rings (13) and pivot pin (12) that pass through the lever frame (3). The float (5) and float arm (10) will be free from the cover. Disconnect float from float arm (10).

## **DISASSEMBLY (Cont'd)**

4. To remove lever frame (3), remove hex-head locator (21). Rotate seat (4) counter-clockwise to remove.
5. Remove orifice button (11) from float arm (10).
6. Clean and inspect parts. Note: some floats contain sand for extra weight; if water is detected, replace float. Replace worn parts as necessary and lubricate parts with FDA grease such as Lubriko #CW-606.

## **REASSEMBLY**

All parts must be cleaned and gasket surfaces should be cleaned with a stiff wire brush in the direction of the serrations or machine marks. Worn parts, gaskets and seals should be replaced during reassembly. Refer to Figure 2 on page 2.

1. Assemble lever frame (3) to cover. Secure with bolt (21) and washers (30).
2. Apply Loctite PST No. 565 thread sealant to seat (4) and assemble to cover with maximum torque of 20 ft-lbs; DO NOT OVER-TORQUE.
3. Install new orifice button (11) flush to arm (10).
4. Connect arm (10) to float (5) with retainer bolt (17) and lockwasher (34). Install pivot pin (12) and retaining rings (13); rings should snap over pins.
5. Float should move freely pressing the orifice button (11) against the seat (4) when pushed upward. Verify that all retainer rings (13) are properly secured.
6. Lay new cover gasket over body (1) and install cover (2) over bolt holes in body (1).
7. Insert lubricated bolts (7) and tighten to 10-20 ft-lbs.
8. Place valve back in service. Refer to the Installation instructions on page 2. Slowly open inlet isolation valve.

## **PARTS AND SERVICE**

Parts and service are available from your local representative or the factory. Make note of the valve Model No and Working Pressure located on the valve nameplate and contact:

Val-Matic Valve and Mfg. Corp.  
905 Riverside Drive  
Elmhurst, IL 60126  
PH: 630/941-7600  
FAX: 630/941-8042

A sales representative will quote prices for parts or arrange for service as needed.

#### LIMITED WARRANTY

All products are warranted to be free of defects in material and workmanship for a period of one year from the date of shipment, subject to the limitations below.

If the purchaser believes a product is defective, the purchaser shall: (a) Notify the manufacturer, state the alleged defect and request permission to return the product; (b) if permission is given, return the product with transportation prepaid. If the product is accepted for return and found to be defective, the manufacturer will, at his discretion, either repair or replace the product, f.o.b. factory, within 60 days of receipt, or refund the purchase price. Other than to repair, replace or refund as described above, purchaser agrees that manufacturer shall not be liable for any loss, costs, expenses or damages of any kind arising out of the product, its use, installation or replacement, labeling, instructions, information or technical data of any kind, description of product use, sample or model, warnings or lack of any of the foregoing. NO OTHER WARRANTIES, WRITTEN OR ORAL, EXPRESS OR IMPLIED, INCLUDING THE WARRANTIES OF FITNESS FOR A PARTICULAR PURPOSE AND MERCHANTABILITY, ARE MADE OR AUTHORIZED. NO AFFIRMATION OF FACT, PROMISE, DESCRIPTION OF PRODUCT OF USE OR SAMPLE OR MODEL SHALL CREATE ANY WARRANTY FROM MANUFACTURER, UNLESS SIGNED BY THE PRESIDENT OF THE MANUFACTURER. These products are not manufactured, sold or intended for personal, family or household purposes.

**VAL-MATIC®**

**VAL-MATIC® VALVE AND MANUFACTURING CORP.**

905 RIVERSIDE DR. ELMHURST, IL. 60126  
TEL. 630/941-7600 FAX. 630/941-8042