

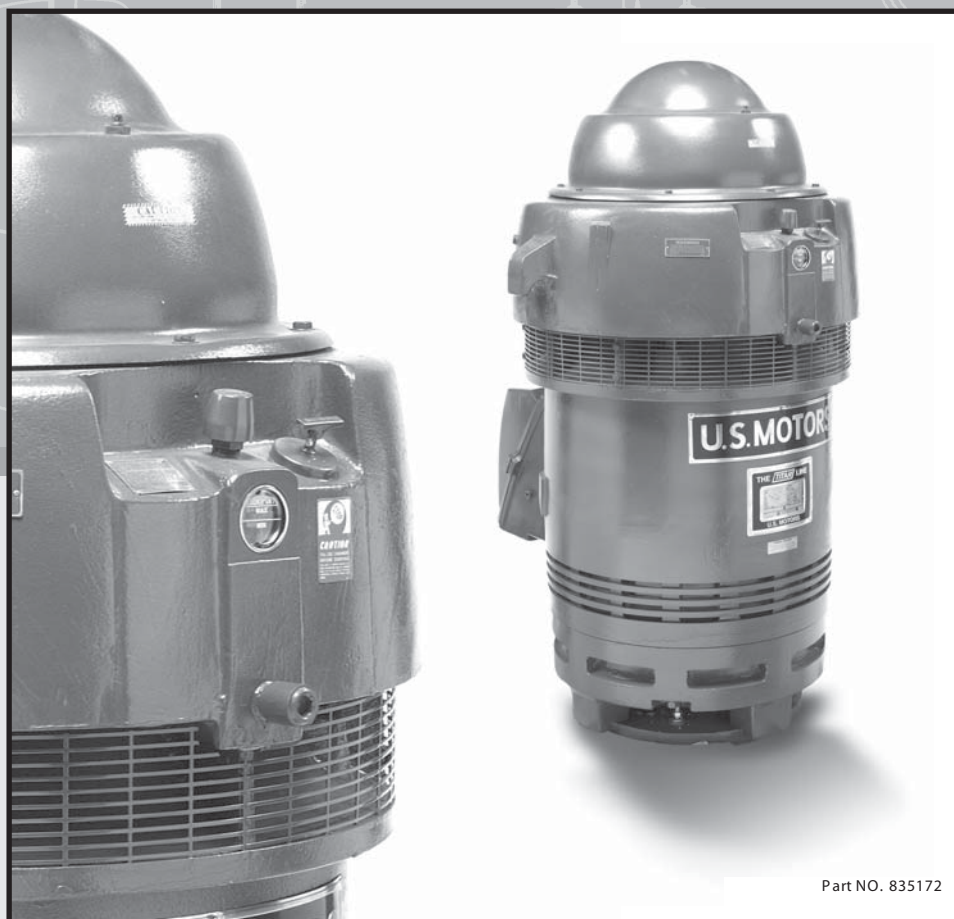

Vertical High Thrust Motors



Installation, Operation, and Maintenance



EMERSON. CONSIDER IT SOLVED.™

©Emerson Motor Company, 2003; All Rights Reserved



SAFETY FIRST!

High voltage and rotating parts can cause serious injury or loss of life. Installation, operation, and maintenance must be performed by qualified personnel. Familiarization with and adherence to NEMA MG2, the National Electrical Code, and local codes is recommended. It is important to observe safety precautions to protect personnel from possible injury. Personnel should be instructed to:

1. Disconnect all power to motor and accessories prior to initiating any installation, maintenance, or repairs. Also ensure that driven equipment connected to the motor shaft will not cause the motor to rotate (windmilling of fans, water flowing back through pump, etc.).
2. Avoid contact with rotating parts.
3. Act with care in accordance with this manual's prescribed procedures in handling and installing this equipment.
4. Be sure unit and accessories are electrically grounded and proper electrical installation wiring and controls are used in accordance with local and national electrical codes. Refer to "National Electrical Code Handbook" - NFPA No. 70. Employ qualified electricians.
5. Be sure equipment is properly enclosed to prevent access by children or other unauthorized personnel in order to prevent possible accidents.
6. Be sure shaft key is fully captive before unit is energized.
7. Provide proper safeguards for personnel against rotating parts and applications involving high inertia loads which can cause overspeed.
8. Avoid extended exposure to equipment with high noise levels.
9. Observe good safety habits at all times and use care to avoid injury to yourself or damage to equipment.
10. Be familiar with the equipment and read all instructions thoroughly before installing or working on equipment.
11. Observe all special instructions attached to the equipment. Remove shipping fixtures if so equipped before energizing unit.
12. Check motor and driven equipment for proper rotation and phase sequence prior to coupling. Also check if a unidirectional motor is supplied and note proper rotation.
13. Electric motors can retain a lethal charge even after being shut off. Certain accessories (space heaters, etc.) are normally energized when the motor is turned off. Other accessories such as power factor correction capacitors, surge capacitors, etc. can retain an electrical charge after being shut off and disconnected.
14. Do not apply power correction capacitors to motors rated for operation with variable frequency drives. Serious damage to the drive will result if capacitors are placed between the motor and drive. Consult drive supplier for further information.



I. SHIPMENT 1

II. HANDLING 1

III. STORAGE 1

IV. INSTALLATION LOCATION 5

V. INITIAL INSTALLATION 6

VI. NORMAL OPERATION 10

VII. NON-REVERSE RATCHET 11

VIII. END PLAY ADJUSTMENT 11

IX. LUBRICATION 14

X. TROUBLESHOOTING 18

XI. SPARE PARTS 20

XII. NAMEPLATE & INSTALLATION RECORD 35

APPENDICES

APPENDIX A "EFFECTS OF UNBALANCED LINE VOLTAGE" 37

APPENDIX B "MOTORS APPLIED TO VARIABLE FREQUENCY DRIVES" 38

APPENDIX C "ELECTRIC MOTOR LOAD TEST USING THE WATT-HOUR METER" 39



I. SHIPMENT

Prior to shipment, all motors undergo extensive mechanical and electrical testing, and are thoroughly inspected. Upon receipt of the motor, carefully inspect the unit for any signs of damage that may have occurred during shipment. Should such damage be evident, unpack the motor at once in the presence of a claims adjuster and immediately report all damage and breakage to the transportation company.

When contacting Emerson Motor Co. concerning the motor, be sure to include the complete motor identification number, frame, and type which appear on the nameplate.

II. HANDLING

The equipment needed to handle the motor includes a hoist and spreader bar arrangement (see Figure 1) of sufficient strength to lift the motor safely. The spreader bar should have the lifting rings or hooks positioned to equal the span of the lifting lugs or eyebolts. The lifting lugs or eyebolts are intended to lift the motor weight only.

▲ WARNING

Lifting the motor by other means may result in damage to the motor or injury to personnel.

▲ CAUTION

Do not move motor with oil sumps filled. Sloshing action of oil in sumps can result in oil leaks and motor damage.

FIGURE 1

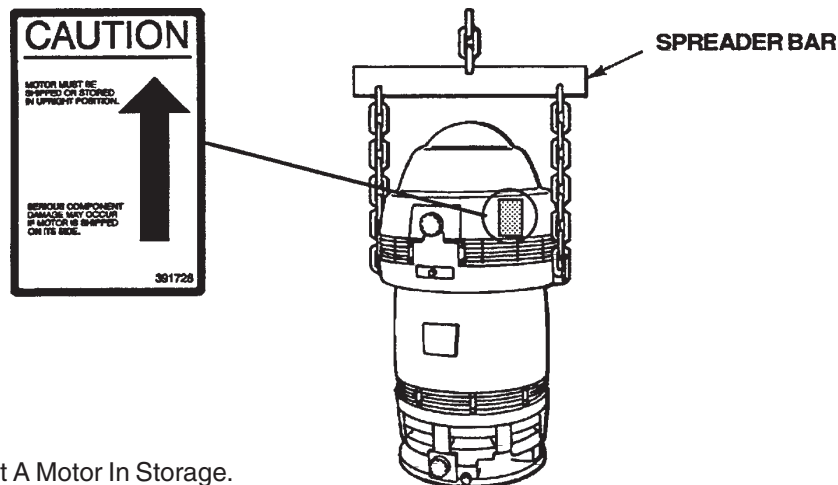

III. STORAGE

1. When To Put A Motor In Storage.

If a motor is not put into immediate service (one month or less), or if it is taken out of service for a prolonged period, special storage precautions should be taken to prevent damage. The following schedule is recommended as a guide to determine storage needs.



- A. Out of service or in storage less than one month - no special precautions except that space heaters, if supplied, must be energized at any time the motor is not running.
 - B. Out of service or in storage for more than one month but less than six months - store per items 2A, B, C, D, E, F(2), and G, items 3A, B, and C, and item 4.
 - C. Out of service or in storage for six months or more - all recommendations.
2. Storage Preparation.

- A. Where possible, motors should be stored indoors in a clean, dry area.
- B. When indoor storage is not possible, the motors must be covered with a tarpaulin. This cover should extend to the ground; however, it should not tightly wrap the motor. This will allow the captive air space to breathe, minimizing formation of condensation. Care must also be taken to protect the motor from flooding or from harmful chemical vapors.

▲ CAUTION

Immediately remove any shrink wrap used during shipping. Never wrap any motor in plastic for storage. This can turn the motor into a moisture trap causing severe, non-warranty damage.

- C. Whether indoors or out, the area of storage should be free from excessive ambient vibration which can cause bearing damage.
- D. Precautions should be taken to prevent rodents, snakes, birds, or other small animals from nesting inside the motors. In areas where they are prevalent, precautions must be taken to prevent insects, such as dauber wasps, from gaining access to the interior of the motor.
- E. Inspect the rust preventative coating on all external machined surfaces, including shaft extensions. If necessary, re-coat the surfaces with a rust preventative material, such as Rust Veto No. 342 (manufactured by E.F. Houghton Co.) or an equivalent. The condition of the coating should be checked periodically and surfaces re-coated as needed.
- F. Bearings:
 - (1) When storage time is 6 months or more, grease lubricated cavities must be completely filled with lubricant. Remove the drain plug and fill cavity with grease until grease begins to purge from drain opening. Refer to section IX. "LUBRICATION" and/or review motor's lubrication nameplate for correct lubricant.

▲ CAUTION

Do not re-grease bearings with drain closed or with unit running.

- (2) Oil lubricated motors are shipped without oil. When storage time exceeds one (1) month, the oil sumps must be filled to the maximum capacity as indicated on the oil chamber sight gauge window. Refer to motor lubrication nameplate or Section IX "Lubrication" for proper oil.



NOTE: Motor must not be moved with oil in reservoir. Drain oil before moving to prevent sloshing and possible damage. With a clean cloth, wipe any excess oil from the threads of the drain plug and the inside of the drain hole. Apply Gasoila P/N SS08 or equivalent thread sealant to the threads of the drain plug and replace the plug in the oil drain hole. Refill oil when motor has been moved to the new location.

G. To prevent moisture accumulation, some form of heating must be utilized. This heating should maintain the winding temperature at a minimum of 5° above ambient. If space heaters are supplied, they should be energized. If none are available, single phase or "trickle" heating may be utilized by energizing one phase of the motor's winding with a low voltage. Request the required voltage and transformer capacity from Emerson Motor Co. A third option is to use an auxiliary heat source and keep the winding warm by either convection or blowing filtered warm air into the motor.

3. Periodic Maintenance.

A. Oil should be inspected monthly for evidence of moisture or oxidation. The oil must be replaced whenever contamination is noted or every twelve months; whichever occurs first. It is important to wipe excess oil from the threads of the drain plug and the drain hole and to coat the plug threads with Gasoila P/N SS08 or equivalent thread sealant before replacing the drain plug.

B. Grease lubricated bearings must be inspected once a month for moisture and oxidation by purging a small quantity of grease through the drain. If any contamination is present, the grease must be completely removed and replaced.

C. All motors must have the shaft rotated once a month to maintain a lubricant film on the bearing races and journals.

D. Insulation History:

The only accurate way to evaluate the condition of the winding insulation is to maintain a history of the insulation readings. Over a period of months or years these readings will tend to indicate a trend. If a downward trend develops, or if the resistance drops too low, thoroughly clean and dry the windings, retreating if necessary, by an authorized electrical apparatus service shop.

The recommended insulation resistance test is as follows:

(1) Using a megohm meter, with winding at ambient temperature, apply DC voltage (noted below) for sixty seconds and take reading.

Rated Motor Voltage
Up to 600 (inclusive)
601 to 1000 (inclusive)
1001 and up

Recommended DC Test Voltage
500 VDC
500 to 1000 VDC
500 to 2500 VDC
(2500 VDC optimum)



(2) For comparison, the reading should be corrected to a 40°C base temperature. This may be done by utilizing the following formula:

$$R_{40C} = K_t \times R_t$$

Where:

R_{40C} = insulation resistance (in megohms) corrected to 40°C

R_t = measured insulation resistance (in megohms)

K_t = temperature coefficient (from Graph 1)

GRAPH 1

WINDING TEMPERATURE (°C)

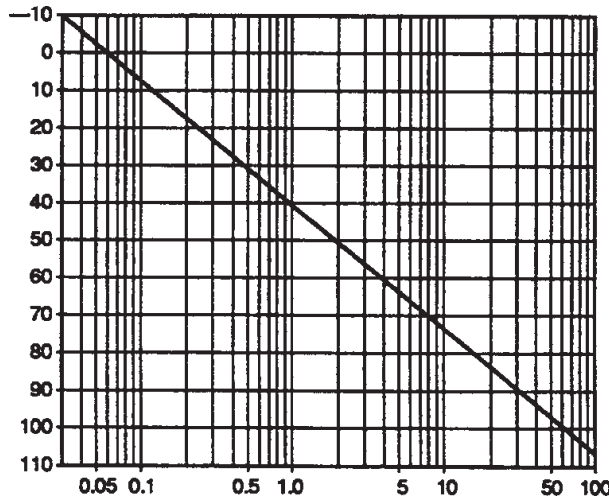

(Adapted from IEEE 43)

INSULATION RESISTANCE TEMPERATURE COEFFICIENT (K_t)

(3) Insulation resistance readings must not drop below the value indicated by the following formula:

$$R_m = K_v + 1$$

Where:

R_m = minimum insulation (in megohms) at 40°C

K_v = rated motor voltage in kilovolts

(4) Dielectric absorption ratio:

In addition to the individual test reading, a dielectric absorption ratio may be required. The dielectric absorption ratio is obtained by taking megohm meter readings at a one minute and ten minute interval, or when hand powered megohm meters are used, at a thirty second and sixty second interval. The voltage should be the same as outlined in part 1 of this procedure.

The ratio is obtained by dividing the second reading by the first reading and is based on a good insulation system increasing its resistance when subjected to a test voltage for a period of time.



10 Minute: 1 Minute

Dangerous = Less than 1.0
Poor = 1.0 to 1.4
Questionable = 1.5 to 1.9
Fair = 2.0 to 2.9
Good = 3.0 to 4.0
Excellent = Over 4.0

60 Second: 30 Second

Poor = Less than 1.1
Questionable = 1.1 to 1.24
Fair = 1.25 to 1.3
Good = 1.4 to 1.6
Excellent = Over 1.6

If a low insulation resistance reading is obtained in either the individual test or dielectric absorption ratio test, thoroughly clean and dry the windings. Recheck insulation resistance and dielectric absorption ratio.

NOTE: Slightly lower dielectric absorption ratios may be acceptable when high initial insulation resistance readings are obtained (1000 + megohms). Refer any questions to Emerson Motor Co. Product Service Department.

For additional information on insulation testing, refer to IEEE Transaction No. 43.

4. Start-up Preparations After Storage.

- A. Motor should be thoroughly inspected and cleaned to restore to an "As Shipped" condition.
- B. Motors which have been subjected to vibration must be disassembled and each bearing inspected for damage.
- C. When storage time has been six (6) months or more, oil and/or grease must be completely changed using lubricants and methods recommended on the motor's lubrication plate, or in Section **IX - "LUBRICATION."**
- D. The winding must be tested to obtain insulation resistance and dielectric absorption ratio as described in Section **III., item 3.**
- E. Contact Emerson Motor Co. Product Service Department prior to start-up if storage time has exceeded one year.

IV. INSTALLATION LOCATION

When selecting a location for the motor and driven unit, keep the following items in mind:

1. The location should be clean, dry, well ventilated, properly drained, and provide accessibility for inspection, lubrication, and maintenance. Outdoor installations on open dripproof motors require protection from the elements.
2. The location should provide adequate space for motor removal without shifting the driven unit.
3. Temperature rise of a standard motor is based upon operation at an altitude not exceeding 3300 feet (1000 meters) above sea level unless specified otherwise on nameplate.



4. To avoid condensation inside the motor, it should not be stored or operated in areas subject to rapid temperature changes unless it is energized or protected by space heaters.
5. The motor should not be installed in close proximity to any combustible material or where flammable gases may be present, unless it is specifically built for that environment and is U.L. labeled accordingly.
6. Oil lubricated motors must be mounted within one degree of true vertical. Failure to do so will result in oil leakage and possibly bearing failure.

V. INITIAL INSTALLATION

1. General

Reliable, trouble free operation of a motor and driven unit depends on a properly designed foundation and base plus good alignment. If the motor and driven unit are not installed properly, the following may result:

- * Noisy operation
- * Excessive vibration
- * Bearing damage or failure
- * Motor failure

2. Shaft Alignment

On Holloshaft motors, the pump shaft and motor coupling must be aligned within .003" TIR. On Solidshaft motors, the motor and pump shafts must be aligned within .002" TIR.

3. Pump Shaft Adjustment (Holloshaft motors only)

To facilitate axial pump shaft adjustment, a locking feature is provided to lock the motor shaft against rotation. The two types of locking features are as follows:

- A. Locking arm (Figure 2) -The locking arm is bolted to a stationary part and is pinned (for best results use arm in tension) or interferes with a rotating part (when locking arm is not in use it should be moved out of the way and bolted in place). A non-reverse ratchet functions as a locking device. Motors supplied with non-reverse ratchets are not equipped with a locking arm.
- B. Pinning through mating holes-Holes are provided in both a stationary and rotating part which line up allowing insertion of a pin.

FIGURE 2

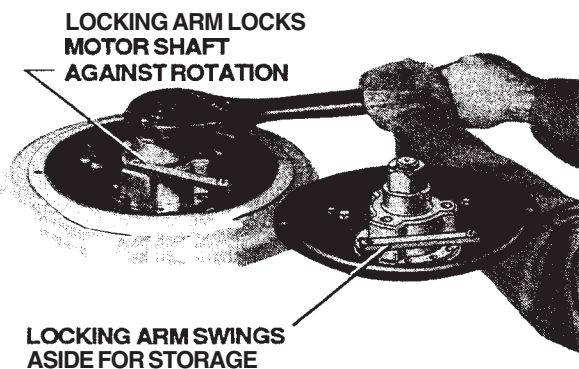

▲ WARNING

Locking device must be disengaged prior to starting motor or motor damage and/or injury to personnel may result.



⚠ CAUTION

Care should be exercised when lowering the motor over the pump shaft so that the oil retaining tube in the lower bracket is not damaged (applies only to motors with oil lubricated lower bearing).

4. Drive Coupling (Holloshaft units only).

The drive coupling may be utilized in one of two ways:

- A. Bolted type (Figure 3) - Hold down bolts are installed (some motors require removal of driving pins to allow installation of hold down bolts) in the drive coupling to prevent upward movement of the pump shaft. This will allow momentary upthrust from the pump to be taken by the motor's guide bearing.

⚠ WARNING

Failure to tighten coupling and non-reverse ratchet bolts to required torque values may cause bolts to break, resulting in equipment damage or injury to personnel.

**BOLTED COUPLING
FIGURE 3**

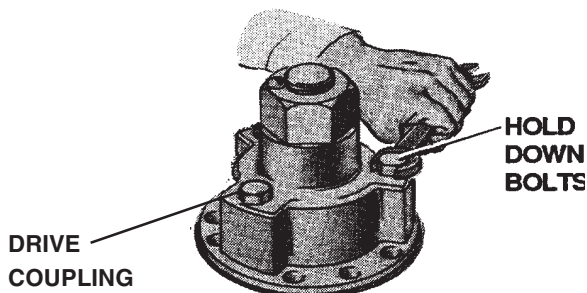

**SELF RELEASE COUPLING
FIGURE 4**

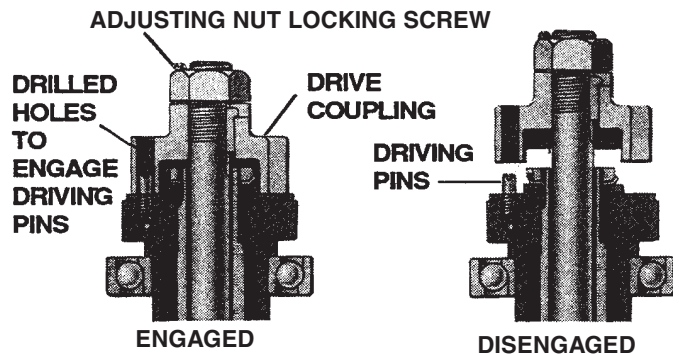

- B. Self-release type (Figure 4) - Driving pins are used to engage the drive coupling with the rotor. A power reversal may unscrew the joints of the pump shafting, causing the shafting to lengthen and buckle or break if the shafting is restrained. The self-release coupling will lift out of engagement with partial unscrewing of the shafting, thus stopping further rotation of the pump. The following items must be followed for proper functioning of the self-release coupling:

- The pump shaft adjusting nut must be properly secured to the drive coupling with a locking screw.
- The drive coupling should not bind on the driving pins.
- The drive coupling must not be bolted down.
- The pump shaft must be concentric to the motor shaft to prevent rubbing of the pump shaft inside the motor shaft.
- There must be no potential for upthrust in the application.
- Do not use the self-release feature in conjunction with a lower steady bushing, as friction between the parts can damage the line shafting and/or bushing.
- Due to the possibility of sparking as the parts separate, the self-release feature must not be used in an environment where explosive gases or dust may be present.



▲ WARNING

Should a motor supplied with a self-release coupling become uncoupled, the motor and pump must be stationary and all power locked out before manually re-coupling.

5. Water Cooling For Bearing Oil Reservoir.

If the motor is equipped with cooling coils in the oil reservoir, a minimum water supply of 4 GPM must be maintained at a maximum of 125 PSI with a 32°C (90°F) maximum inlet temperature. External water connections must be self draining to prevent cooling coil rupture at freezing temperatures. Use clean, noncorrosive water only. If corrosive conditions exist and are specified at time of motor order, special corrosion resistant fittings can be supplied.

6. Electrical Connection.

Refer to the motor nameplate for power supply requirements and to the connection diagram on the motor. Be sure connections are tight. Check carefully and assure that they agree with the connection diagram, then carefully tape all connections with electrical tape to be sure that they will not short against each other or to ground. Be sure the motor is grounded to guard against possible electrical shock. Refer to the National Electrical Code Handbook (NFPA No. 70) and to local electrical codes for proper wiring, protection, and wire sizing. Be sure proper starting equipment and protective devices are used for every motor. For assistance contact the local sales office of the motor starter manufacturer for the particular brand of equipment you are using.

Part Winding Starters: Part winding starters used with part winding start motors should have the timer set at a minimum time consistent with the power company requirements. The recommended maximum time on part winding is two seconds. Setting the timer for longer periods can cause permanent damage to the motor and may void the warranty. Note that motor may or may not start on part winding start connection.

7. Direction Of Rotation.

As a standard, motors that are equipped with a non-reverse ratchet are designed to operate in a counter-clockwise direction as viewed from the top of the motor. Also, some high speed motors have unidirectional ventilating fans. When the motor has a unidirectional ventilating fan, the direction of rotation is indicated by an arrow mounted on the motor and by a warning plate mounted near the main nameplate.

▲ CAUTION

Apply power momentarily to observe the direction of rotation for which the leads are connected. Motor damage may occur if power is applied for more than ten seconds while rotation is locked against the non-reverse ratchet. The motor should be uncoupled from the driven equipment during this procedure to assure driven equipment is not damaged by reverse rotation. Couplings (if installed) should be properly secured.

For a 3 phase motor, to reverse the direction of rotation (if the motor is not operating in the correct direction), interchange any two of the three power leads on the motor. For a 1 phase motor, if the motor is not operating in the correct direction, follow the instructions on the connection plate attached to the motor in order to reverse the direction of rotation. For both 1 and 3 phase motors, be sure that the power is off and steps are taken to prevent accidental starting of the motor before attempting to change electrical connection.



8. Spring-Preloaded Thrust Bearings.

Motors built with spherical roller thrust bearings (bearing number 29xxx) at any speed or tandem angular contact thrust bearings (bearing number 7xxx) on large 3600 or 3000 RPM (2-pole) motors have preload springs which maintain a minimum thrust load at all times to prevent bearing skidding. These motors require a minimum external thrust load sufficient to compress the springs to properly seat the thrust bearing and to relieve the lower guide bearing of axial spring thrust. Refer to motor's minimum thrust nameplate for required thrust.

⚠ CAUTION

Do not run a motor which has bearing preload springs without thrust load for more than fifteen (15) minutes as bearing damage may result.

9. Initial Start.

After installation is completed, but before motor is put into regular service, make an initial start as follows:

- A. Ensure that motor and control device connections agree with wiring diagrams.
- B. Ensure that voltage, phase, and frequency of line circuit (power supply) agree with motor nameplate.
- C. Check insulation resistance according to Section III "STORAGE" item 3.
- D. Check all foundation, base, non-reverse ratchet (if applicable), and coupling bolts (if applicable) to ensure they are tight.
- E. If motor has been in storage, either before or after installation, refer to Section III "STORAGE" item 4 for preparations.
- F. Check oil lubricated units to be certain that bearing housings have been filled to between the "MAX" and "MIN" levels on the sight gauge windows with the correct lubricant. Refer to Section IX "LUBRICATION" for proper oils.
- G. Check for proper or desired rotation. See item 7 of this section for details.
- H. Ensure that all protective devices are connected and operating properly, and that all outlet accessory, and access covers have been returned to their original intended position.
- I. Start motor at lowest possible load and monitor to be sure that no unusual condition develops.

⚠ WARNING

All loosened or removed parts must be reassembled and tightened to original specifications. Keep all tools, chains, equipment, etc. clear of unit before energizing motor.

- J. When checks are satisfactory to this point, increase load slowly up to rated load and monitor unit for satisfactory operation.



VI. NORMAL OPERATION

Start the motor in accordance with standard instructions for the starting equipment used.

1. General Maintenance.

Regular, routine maintenance is the best assurance of trouble-free, long-life motor operation. It prevents costly shutdown and repairs. Major elements of a controlled maintenance program are:

- A. Trained personnel who have a working knowledge of rotational equipment and have read this manual.
- B. Systematic records which contain at least the following:
 - 1. Complete nameplate data.
 - 2. Prints (wiring diagrams, certified outline dimensions).
 - 3. Alignment data.
 - 4. Results of regular inspection, including vibration and bearing temperature data, as applicable.
 - 5. Documentation of any repairs.
 - 6. Lubrication data:
 - Method of application
 - Types of lubricants for wet, dry, hot, or adverse locations
 - Maintenance cycle by location (some require more frequent lubrication)

2. Inspection and Cleaning

Stop the motor before cleaning. **CAUTION: Assure against accidental starting of the motor.** Clean the motor inside and out regularly. The frequency of cleaning depends upon actual conditions existing around the motor. Use the following procedures as they apply:

- A. Wipe off dirt, dust, oil, water, or other liquids from external surfaces of motor. These materials can work into or be carried into the motor windings and may cause overheating or insulation breakdown.
- B. Remove dirt, dust, or debris from ventilating air inlets. Never allow dirt to accumulate near air inlets. Never operate motor with air passages blocked.
- C. Clean motors internally by blowing with clean, dry, compressed air at 40 to 60 PSI. If conditions warrant, use a vacuum cleaner.

▲ CAUTION

When using compressed air, always use proper eye protection to prevent accidental eye injury.

- D. When dirt and dust are solidly packed, or windings are coated with oil or greasy grime, disassemble the motor and clean with solvent. Use only high-flash naphtha, mineral spirits, or Stoddard solvent. Wipe with solvent dampened cloth, or use suitable soft bristled brush. **DO NOT SOAK.** Oven dry (150 – 175°F) solvent cleaned windings thoroughly before reassembly.
- E. After cleaning and drying the windings, check the insulation resistance per Section III, Item 3.



VII. NON-REVERSE RATCHET

Units featuring non-reverse ratchets are refine-balanced by attaching weights to the rotating ratchet. If the ratchet is removed it should be marked and reassembled in the same position to retain proper balance.

VIII. ENDPLAY ADJUSTMENT

The term *endplay* is defined as the total axial float of the rotor. Should the motor be disassembled for any reason, the rotor endplay must be adjusted. Care must be taken to ensure that end play is within the proper range. Use one of the following procedures, depending upon the type of thrust bearing to set end play:

▲ CAUTION

Excessive endplay can allow the thrust bearing to separate when units are run with zero thrust or momentary up thrust, resulting in thrust bearing failure. Insufficient endplay may cause the bearings to load against each other, resulting in extreme heat and rapid failure of both the guide and thrust bearings.

1. Spherical Roller Thrust Bearings and Angular Contact Bearings (With Springs).

Setting the correct end play on units with spring-preloaded spherical roller or angular contact thrust bearings requires a controlled assembly method, due to various deflections internal to the motor and friction of locknut threads from spring force. An end play setting of .005 to .008 inches is required to allow the lower guide bearing to return to an unloaded position when external thrust is applied to the motor (see Figure 5). End play can be properly adjusted by the following recommended procedure:

- A. Place spring retainer (without springs) and lower thrust washer of bearing into upper bearing bore.
- B. Using a depth micrometer, measure the distance between the top of the lower thrust washer and the faced surface on top of the bearing housing (see Figure 5). Record dimension to three decimals.
- C. Add .005 to .008 inches to the recorded dimension to obtain the correct endplay range for the unit.
- D. Reassemble bearing with springs. Motor is now ready to set end play. Several acceptable methods for setting endplay are following.

NOTE: Certain motor builds require removal of the fabricated steel or cast aluminum oil baffle to provide access for depth micrometer measurements.

FIGURE 5

SPHERICAL ROLLER THRUST BEARING

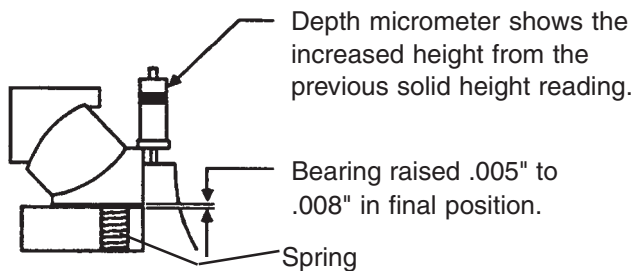

ANGULAR CONTACT BEARING

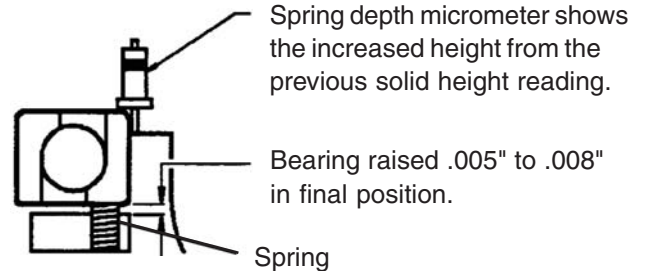



2. Angular Contact Ball Bearings (Without Springs)

- A. No preliminary measurements are required to set end play. End play may be set by any of the following methods described in this section.
- B. To correctly adjust the endplay setting, a dial indicator should be positioned to read the shaft axial movement. (See figure 7 for location of dial indicator). The rotor adjusting lock nut should be turned until no further upward movement of the shaft is indicated. The locknut is then loosened until .005 to .008" endplay is obtained. Lock the locknut with lock washer.

▲ CAUTION

Care should be taken to ensure that the locknut is not over-tightened, as this can lead to an erroneous end play setting (due to deflection of parts) and bearing damage may result.

- C. Motors that have two opposed angular contact bearings that are locked for up and downthrust do not require endplay adjustment. The shaft, however, must be set to the original 'AH' (shaft extension length) to prevent the guide bearing from taking thrust.

ENDPLAY ADJUSTMENT METHODS

1. Method 1 (refer to Figures 6 & 7)

This method requires the user to install a bolted chain from the bearing mount back to a lifting lug. Rotate the locknut with a spanner wrench (and bar extension) until dial indicator shows no movement on end of shaft. The locknut should then be loosened until proper endplay is obtained, lock the locknut with lock washer. (See figure 7 for location of dial indicator.)

NOTE: This is the lowest cost of the three methods and requires the least amount of equipment. This method, however, may be less desirable than Method 2 as considerable locknut torque may be encountered on units with bearing preload springs.

- Special equipment required:
- Locking bolts
 - Dial indicator
 - 3/4" chain
 - Depth micrometer
 - Spanner wrench with extension

FIGURE 6 (METHOD 1)

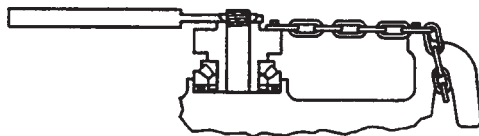

MOUNTING SPRINGS ARE COMPRESSED AND ROTOR IS LIFTED BY LOCKNUT

FIGURE 7 (METHOD 1 & 3)

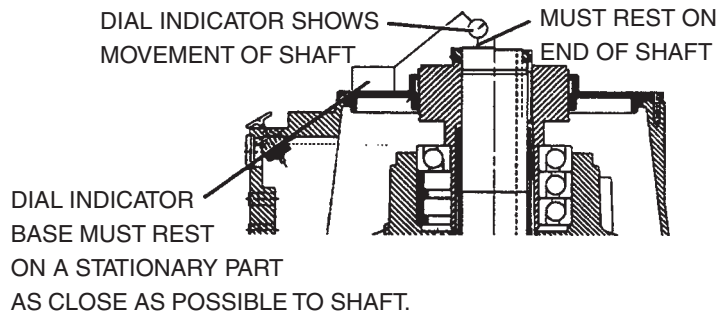



2. Method 2 (refer to Figure 8 - Utilized on Spring Loaded Bearings Only)

This method utilizes a spreader bar and chains to wrap around lifting lugs, a hydraulic jack (five ton), and crane to lift the spreader bar. The hydraulic jack is supported by two steel blocks of equal thickness on top of the bearing mounting with the jack pushing against the spreader bar. On large motors, the rotor can be lifted by placing a second jack below the motor shaft to allow the locknut to be turned easily.

NOTE: This method utilizes typical shop equipment and tools. Endplay settings can be checked quickly on larger vertical motor products. The locknut lifts rotor weight only.

Equipment required:

- Large spreader bar with chains and locking bolts
- Overhead crane
- Metal blocks
- Depth micrometer
- 5-ton hydraulic jack
- Spanner wrench
- Dial indicator

FIGURE 8 (METHOD 2)

MOUNTING SPRINGS ARE COMPRESSED – ONLY THE ROTOR IS LIFTED BY THE LOCKNUT.

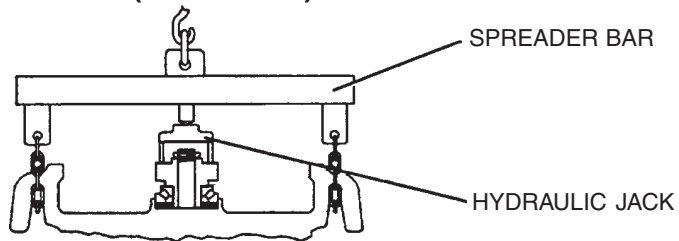

3. Method 3 (refer to Figure 9)

This method uses a one inch thick steel disc with a center hole for the shaft end bolt and two threaded hydraulic jacks connected to a single pump. Apply load to hydraulic jacks until dial indicator shows no movement on end of shaft. (See figure 7 for location of dial indicator). The shaft locknut should be positioned and the pressure from hydraulic jack relieved until proper endplay is obtained.

▲ CAUTION

Use of excessive hydraulic pressure can damage bearings.

NOTE: This method is directly usable on solid shaft motors and can be used on most HOLLOWSHAFT motors with the use of a long threaded rod and plate. It is easy to apply and settings can be checked quickly, especially in field service. The locknut does not see any force and can be turned easily.

Equipment required:

- Fixture with hydraulic jacks
- Dial indicator
- Spanner wrench

MOUNTING SPRINGS ARE COMPRESSED AND ROTOR IS LIFTED BY THE FIXTURE. THE LOCKNUT IS TURNED FOR ADJUSTMENT.

FIGURE 9 (METHOD 3)

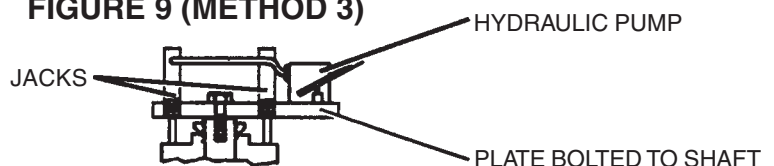

▲ CAUTION

After setting endplay, run unit for three to five minutes, then stop and verify the endplay setting. Readjust as necessary. All loosened or removed parts must be reassembled and tightened to original specifications. Keep all tools, chains, equipment, etc. clear of unit before energizing motor.



IX. LUBRICATION

Motor must be at rest and electrical controls should be locked open to prevent energizing while being serviced. If motor is being taken out of storage refer to Section III “STORAGE”, item 4 for instructions.

1. Oil Lubricated Bearings.

Change oil once per year with normal service conditions. Frequent starting and stopping, damp or dusty environment, extreme temperature, or any other severe service conditions will warrant more frequent oil changes. If there is any question, consult Emerson Motor Co. Product Service Department for recommended oil change intervals regarding your particular situation.

Determine required oil ISO Viscosity Grade (VG) and base oil type from Table 3, then see Table 4 for approved oils. Add oil into oil fill hole at each bearing housing until the oil level reaches between minimum and maximum marks located on the sight gauge window. It is important to wipe excess oil from the threads of the drain hole and to coat the plug threads with Gasoila P/N SS08, manufactured by Federal Process Corporation or equivalent thread sealant before replacing the drain plug. Plug should be tightened to a minimum of 20 lb.-ft. using a torque wrench. See the motor nameplate or Table 5 for the approximate quantity of oil required.

2. Grease Lubricated Bearings.

A. Relubrication of Units in Service

Grease lubricated bearings are pre-lubricated at the factory and normally do not require initial lubrication. Relubricating interval depends upon speed, type of bearing and service. Refer to Table 1 for suggested regreasing intervals and quantities. Note that operating environment and application may dictate more frequent lubrication.

To relubricate bearings, remove the drain plug. Inspect grease drain and remove any blockage (caked grease or foreign particles) with a mechanical probe, taking care not to damage bearing.

▲ WARNING

Under NO circumstances should a mechanical probe be used while the motor is in operation.

Add new grease at the grease inlet. New grease must be compatible with the grease already in the motor (refer to table 2 for compatible greases).

▲ CAUTION

Greases of different bases (lithium, polyurea, clay, etc.) may not be compatible when mixed. Mixing such greases can result in reduced lubricant life and premature bearing failure. Prevent such inter-mixing by disassembling motor, removing all old grease and repacking with new grease per item B of this section. Refer to Table 2 for recommended greases.

Run the motor for 15 to 30 minutes with the drain plug removed to allow purging of any excess grease. Shut off unit and replace the drain plug. Return motor to service.

▲ CAUTION

Overgreasing can cause excessive bearing temperatures, premature lubricant breakdown and bearing failure. Care should be exercised against overgreasing.



B. Change of Lubricant

Motor must be disassembled as necessary to gain full access to bearing housing(s).

Remove all old grease from bearings and housings (including all grease fill and drain holes). Inspect and replace damaged bearings. Fill bearing housings both inboard and outboard of bearing approximately 30 percent full of new grease. Grease fill ports must be completely charged with new grease. Inject new grease into bearing between rolling elements to fill bearing. Remove excess grease extending beyond the edges of the bearing races and retainers.

**Table 1
Recommended Grease Replenishment Quantities & Lubrication Intervals**

Bearing Number		Grease Replenishment Quantity (Fl. Oz.)	Lubrication Interval		
62xx, 72xx	63xx, 73xx		1801 thru 3600 RPM	1201 thru 1800 RPM	1200 RPM and slower
03 thru 07	03 thru 06	0.2	1 Year	2 Years	2 Years
08 thru 12	07 thru 09	0.4	6 Months	1 Year	1 Year
13 thru 15	10 thru 11	0.6	6 Months	1 Year	1 Year
16 thru 20	12 thru 15	1.0	3 Months	6 Months	6 Months
21 thru 28	16 thru 20	1.8	3 Months	6 Months	6 Months

Refer to motor nameplate for bearings provided on a specific motor.

For bearings not listed in Table 1, the amount of grease required may be calculated by the formula:

$$G = 0.11 \times D \times B$$

Where: G = Quantity of grease in fluid ounces.
D = Outside diameter of bearing in inches.
B = Width of bearing in inches.

**Table 2
Recommended Greases**

Motor Frame Size	Motor Enclosure	Grease Manufacturer	Grease (NLGI Grade 2)
All Thru 447	All	Chevron USA, Inc. Exxon Mobil	Grease No. 83343 SRI No. 2 Polyrex-EM
449 and Up	Open Dripproof		
449 and Up	TEFC and Explosionproof	Exxon Mobil	Grease No. 974420 Mobilith SHC-100

The above greases are interchangeable with the grease provided in units supplied from the factory (unless stated otherwise on motor lubrication nameplate).



**Table 3
Emerson Motor Co. Recommended Oil Viscosities**

Angular Contact Thrust Bearing (7XXX Series)					
Motor Enclosure	Frame Size	Speed (RPM)	Ambient Temperature	ISO VG	Base Oil Type
Open Dripproof or Weather Protected	324 and Larger	All	-15C thru 40C (5-104F)	32	Mineral or Synthetic
			41C thru 50C (105-122F)	68	Synthetic Only
404 thru 447	-15C thru 40C (5-104F)		32	Mineral or Synthetic	
	41C thru 50C (105-122F)		68	Synthetic Only	
Totally Enclosed or Explosionproof	449 thru 5811	1801 - 3600	-15C thru 40C (104F)	32	Synthetic Only
		1800 & Below		68	Synthetic Only
		All	41C thru 50C (105-122F)	Refer to Office	

Spherical Roller Thrust Bearing (29XXX Series)					
Motor Enclosure	Frame Size	Speed (RPM)	Ambient Temperature	ISO VG	Base Oil Type
Open Dripproof or Weather Protected	444 and Larger	1800 and Below	-15C thru 25C (5-77F)	68	Mineral or Synthetic
			6C thru 40C (42-104F)	150	
			41C thru 50C (105-122F)		68
Totally Enclosed or Explosionproof	449 and Larger		-15C thru 25C (5-77F)	150	Synthetic Only
			6C thru 40C (42-104F)	Refer to Office	
			41C thru 50C (105-122F)		

Notes:

1. If lower guide bearing is oil lubricated, it should use the same oil as the thrust bearing.
2. If lower guide bearing is grease-lubricated, refer to TABLE 2 for recommended greases.
3. Refer to Emerson Motor Co. for ambient temperatures other than those listed.

**Table 4
Emerson Motor Co. Approved Oil Specifications For Use With Anti-Friction Bearings**

Oil Manufacturer	ISO VG 32		ISO VG 68		ISO VG 150	
	Viscosity: 130-165 SSU @ 100F		Viscosity: 284-347 SSU @ 100F		Viscosity: 620-765 SSU @ 100F	
	Mineral Base Oil	Synthetic Base Oil	Mineral Base Oil	Synthetic Base Oil	Mineral Base Oil	Synthetic Base Oil
Chevron USA, Inc	GST Turbine Oil 32	Tegra 32	GST Turbine Oil 68	Tegra 68	R&O Machine Oil 150	Tegra 150
Conoco Oil Co.	Hydroclear Turbine Oil 32	Syncon 32	Hydroclear Turbine Oil 68	Syncon 68	Hydroclear AW Hyd. Fluid 150	N/A
ExxonMobil	Teresstic 32	Synnestic 32	Teresstic 68	Synnestic 68	Teresstic 150	Synnestic 150
ExxonMobil	DTE Oil Light	SHC 624	DTE Oil Heavy Medium	SHC 626	DTE Oil Extra Heavy	SHC 629
Pennzoil Co., Inc	Pennzbell TO 32	Pennzbell SHD 32	Pennzbell TO 68	Pennzbell SHD 68	Pennzbell TO 150	Pennzbell SHD 150
Phillips Petroleum Co.	Magnus 32	Syndustrial "E" 32	Magnus 68	Syndustrial "E" 68	Magnus 150	N/A
Shell Oil Co.	Tellus 32	Tellus HD Oil AW SHF 32	Tellus 68	Tellus HD Oil AW SHF 68	Tellus 150	N/A
Texaco Lubricants Co.	Regal 32	Cetus PAO 32	Regal 68	Cetus PAO 68	Regal 150	N/A



**Table 5
Approximate Oil Sump Capacities**

Frame Size	Motor Type Designation (See Motor Nameplate)	Oil Capacity (Quarts)	
		Upper Bearing	Lower Bearing
180 - 280	AU, AV-4	Grease	Grease
180 - 280	AV		
320 - 440	RV		
320 - 360	RV-4, RU	3	
400	RV-4, RU	5	
440	RV-4 (2 pole)	17	
	RV-4, RU (4 pole & slower, w/ ang contact thrust brg.)	6	
	(4 pole & slower, w/ spherical thrust brg.)	4	
180 - 440	TV-9, TV, LV-9, LV	Grease	
180 -360	TV-4, TU, LV-4, LU		
400	TV-4, TU, LV-4, LU	6	
440	TV-4, TU, LV-4, LU	5	
449	JU, JV-4	22	
	HU, HV-4	12	
	JV-3, JV, HV	Grease	
5000	HV, EV, JV, RV	Grease	
	RU, RV-4	30	
	HU, HV-4 (4 pole & slower)	12	
	HV-4 (2 pole only)	20	
	EU, JU, EV-4, JV-4	22	5
5800	HU, HV-4	24	3
	EU, JU, EV-4, JV-4	37	4
6800	HU, HV-4	70	3
	HV (Bow Thruster)	Grease	Grease
	HV (Other Than Bow Thruster)	70	3
8000	RU, RV-4	70	6
	RV	Grease	Grease
9600	RU, RV-4	64	13
	RV	Grease	Grease



X. FUNDAMENTAL TROUBLESHOOTING - PROBLEM ANALYSIS

This chart can reduce work and time spent on motor analysis. Always check the chart first before starting motor disassembly, as what appears to be a motor problem may often be located elsewhere. For additional information, consult our website at www.usmotors.com.

SYMPTOM	PROBABLE CAUSE	ANALYSIS
Motor fails to start	Defective power supply	Check voltage across all phases above disconnect switch.
	Blown or defective primary fuses	
	Blown or defective secondary fuses	Check voltage below fuses (all phases) with disconnect closed.
	Open control circuit	Push reset button.
	Overload trips are open	
	Defective holding coil in magnetic switch	Push start button and allow sufficient time for operation of time delay, if used, then check voltage across magnetic holding coil. If correct voltage is measured, coil is defective. If no voltage is measured, control circuit is open.
	Loose or poor connections in control circuits.	Make visual inspection of all connections in control switch.
	Magnetic switch closes	Open manual disconnect switch, close magnetic by hand, and examine contractors and springs.
	Poor switch contact	
	Open circuit in control panel	Check voltage at T1, T2, & T3
Open circuit in leads to motor	Check voltage at leads in outlet box	
Leads improperly connected	Check lead numbers and connections.	
Motor fails to come up to speed	Low or incorrect voltage	Check voltage at T1, T2, & T3 in control panel and at motor leads in outlet box.
	Incorrect connection at motor	Check for proper lead connections at motor and compare with connection diagram on motor.
	Overload - mechanical	Check impeller setting. Check for a tight or locked shaft.
	Overload - hydraulic	Check impeller setting. Check GPM against pump capacity and head.
Motor Vibrates	Headshaft misaligned	Remove top drive coupling and check alignment of motor to pump.
	Worn line shaft bearings or bent line shaft	Disconnect motor from pump and run motor only to determine source of vibration.
	Hydraulic disturbance in discharge piping	Check isolation joint in discharge piping near pump head.
	Ambient Vibration	Check base vibration level with motor stopped.
	System Natural Frequency (Resonance)	Revise rigidity of support structure.
Motor noisy	Worn thrust bearing	Remove dust cover, rotate rotor by hand, and make visual examination of balls and races. Bearing noise is commonly accompanied by a high frequency vibration and/or increased temp.
	Electrical noise	Most motors are electrically noisy during the starting period. This noise should diminish as motor reaches full speed.



SYMPTOM	PROBABLE CAUSE	ANALYSIS
<p>Motor overheating (Check with thermocouple or by resistance methods. Do not depend on hand.)</p>	Overload	Measure load and compare to nameplate rating. Check for excessive friction in motor or in complete drive. Reduce load or replace motor with greater capacity motor. Refer to Appendix C.
	Motor intake or exhaust blocked or clogged.	Clean motor intake and exhaust areas. Clean filters or screens if motor is so equipped.
	Unbalanced voltage	Check voltage to all phases. Refer to Appendix A.
	Open stator windings	Disconnect motor from load. Check idle amps for balance in all three phases. Check stator resistance in all three phases.
	Over / Under Voltage	Check voltage and compare to nameplate voltage.
	Ground	Locate with test lamp or insulation tester and repair.
	Improper Connections.	Recheck connections.
<p>Bearing Overheating</p> <p>Generally, bearing temperatures (as measured by a tipsensitive RTD or thermocouple touching the bearing outer race) should not exceed 90°C when using mineral-based lubricants or 120°C when using synthetic-based lubricants.</p>	Misalignment	Check alignment.
	Incorrect oil, or oil level too high or too low.	Refill with proper oil. Verify oil level is correct.
	Excessive thrust.	Reduce thrust from driven machine.
	Bearing over-greased.	Relieve bearing cavity of grease to level specified in lubrication section.
	Motor overloaded	Measure load and compare to nameplate rating. Check for excessive friction in motor or in complete drive. Reduce load or replace motor with greater capacity motor. Refer to Appendix C.
	Motor intake or exhaust blocked or clogged.	Clean motor intake and exhaust areas. Clean filters or screens if motor is so equipped.
<p>Bearing oil leaking around the drain plug.</p>	Insufficient sealant applied to drain plug threads.	Remove drain plug and drain existing oil from sump. With a clean cloth, wipe excess oil from the plug threads and the threads in the drain hole. Apply Gasoil Thread Sealant P/N SS08 to the threads of the plug and replace. Fill sump with new oil to the proper level.



XI. SPARE PARTS

A parts list is available for your unit and will be furnished upon request. Parts may be obtained from local Emerson Motor Co. distributors and authorized service shops, or through Emerson Motor Co. distribution center.

Emerson Motor Co.
710 Venture Drive
Suite 100
Southaven, MS 38672
Phone (662) 342-6910
Fax (662) 342-7350

Drawings for many standard designs are supplied on the following pages. Most of the parts should be easy to identify. If however, there is some deviation from your machine, consult the factory for assistance.



INSTALLATION AND MAINTENANCE

Spare Parts

250 and 280 Frames
Type AU HIGH THRUST

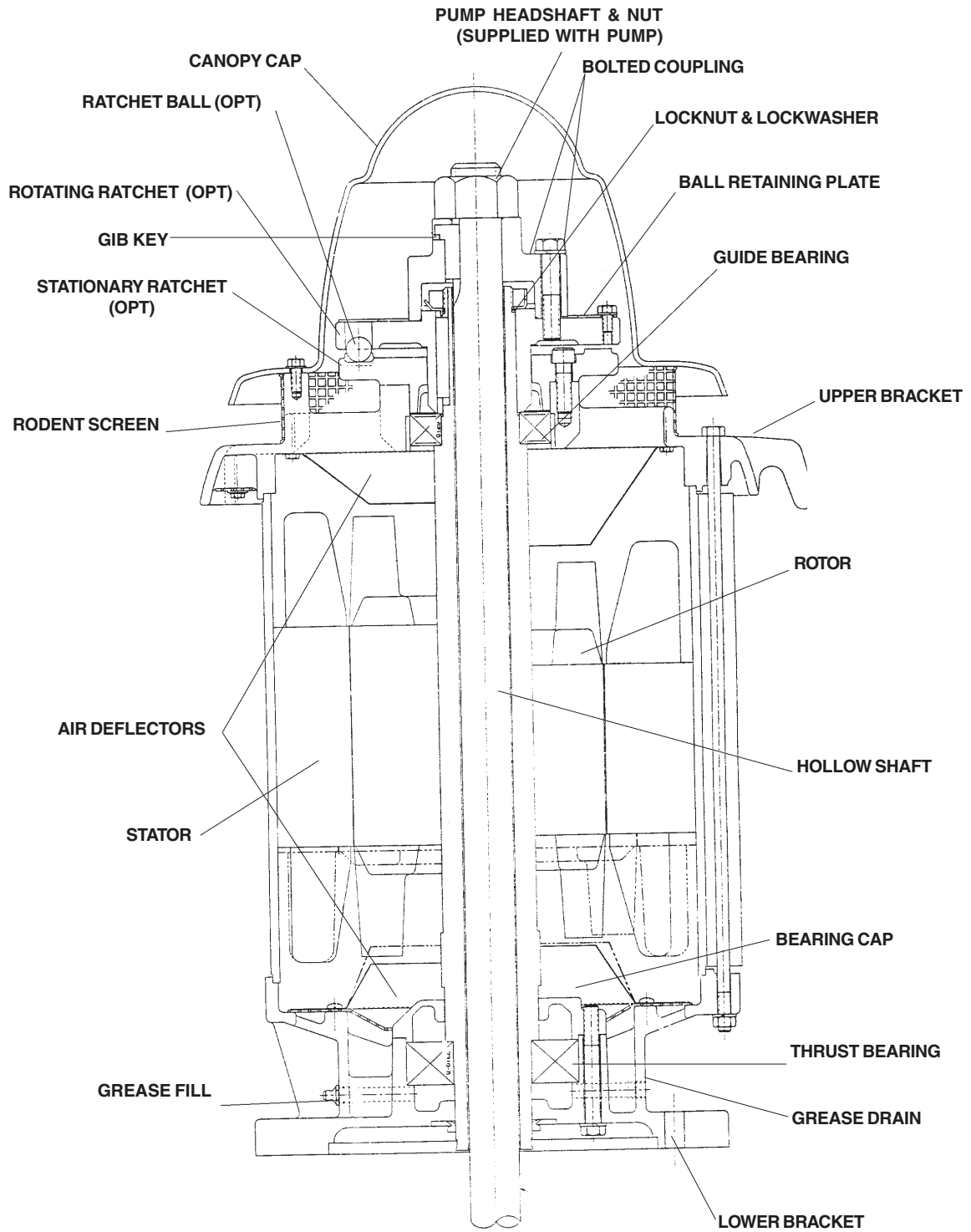



INSTALLATION AND MAINTENANCE

Spare Parts 320 Thru 440 Frame Type RU - High Thrust

PUMP SHAFT ADJUSTING NUT AND LOCKING SCREWS
ARE FURNISHED BY CUSTOMER

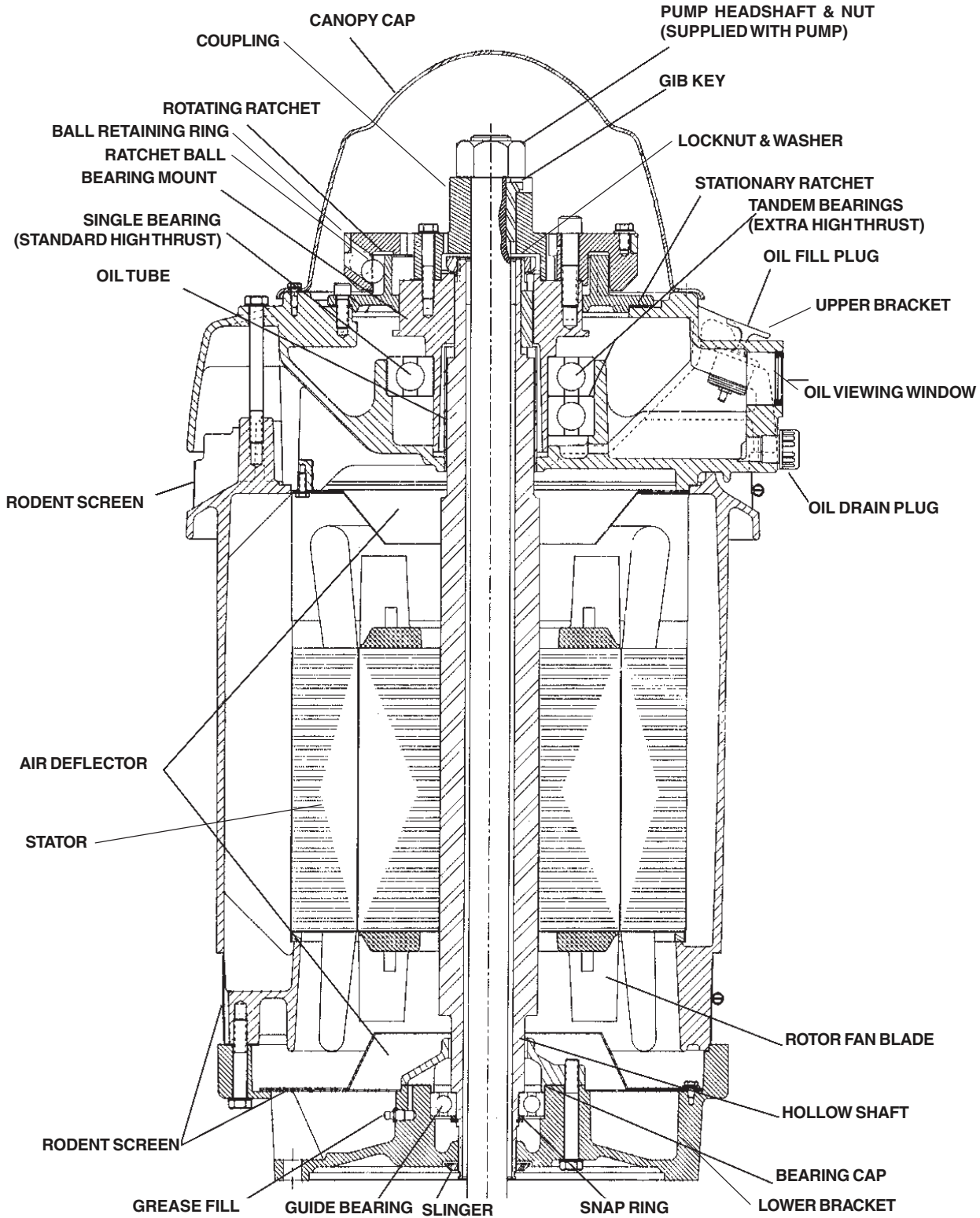



INSTALLATION AND MAINTENANCE

Spare Parts 440 Frame, Type RV-4 (2 Pole)

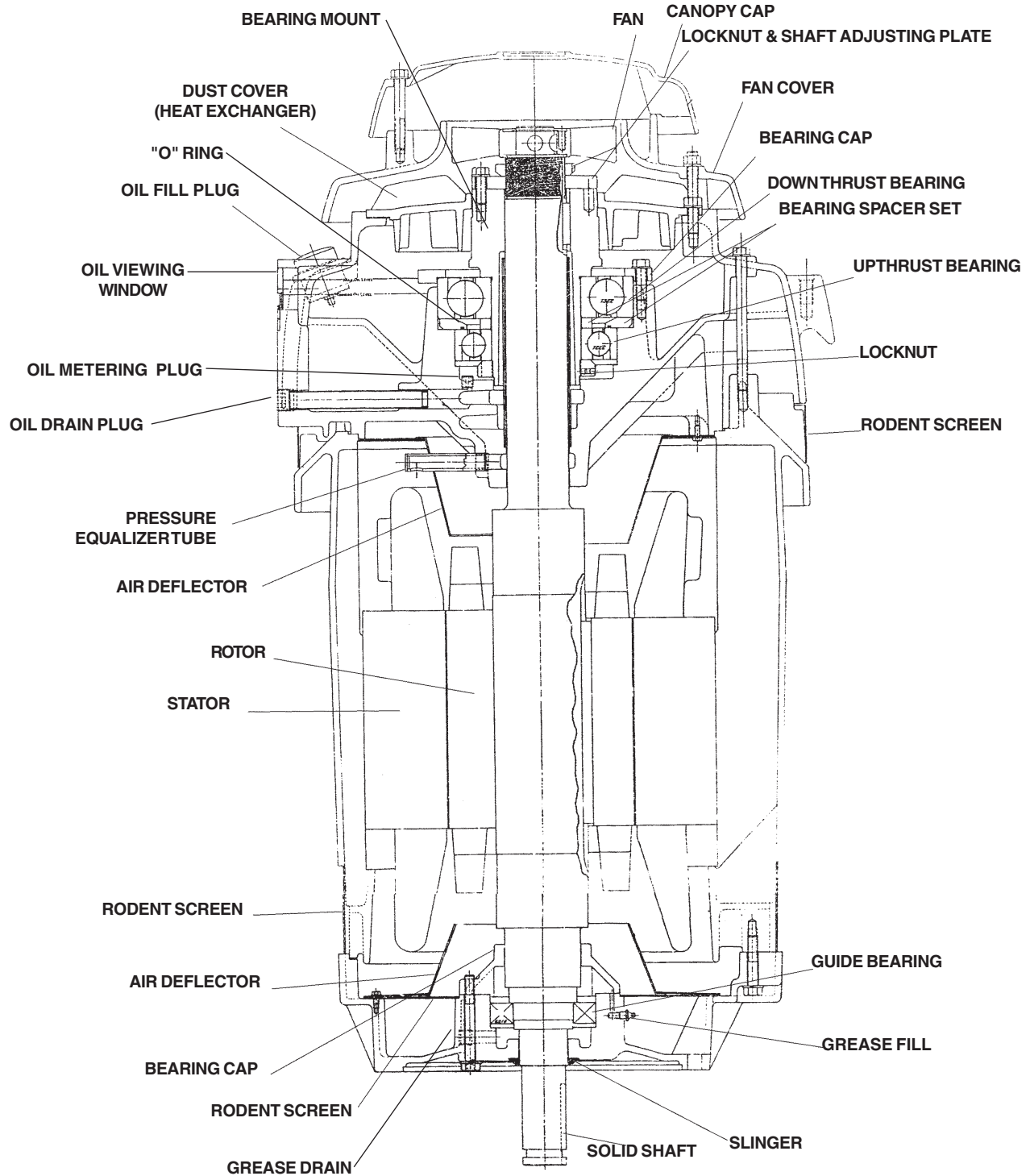



INSTALLATION AND MAINTENANCE

Spare Parts

280, 320, 360 FRAMES, TYPE LU
320, 360 FRAMES TYPE TU

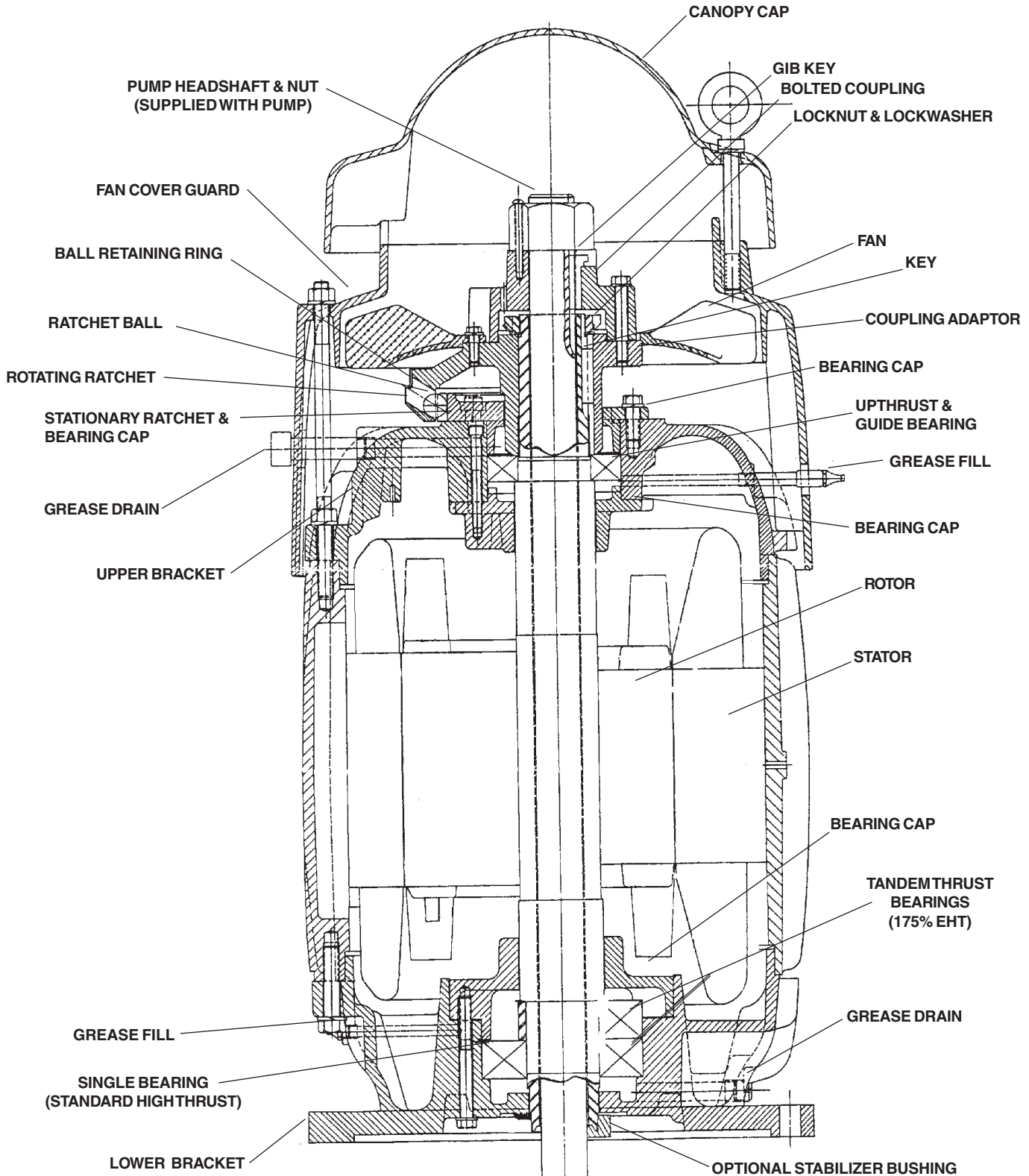



INSTALLATION AND MAINTENANCE

Spare Parts

400 Thru 440 Frame
Types TU, LU, TV-4 and LV-4
High Thrust

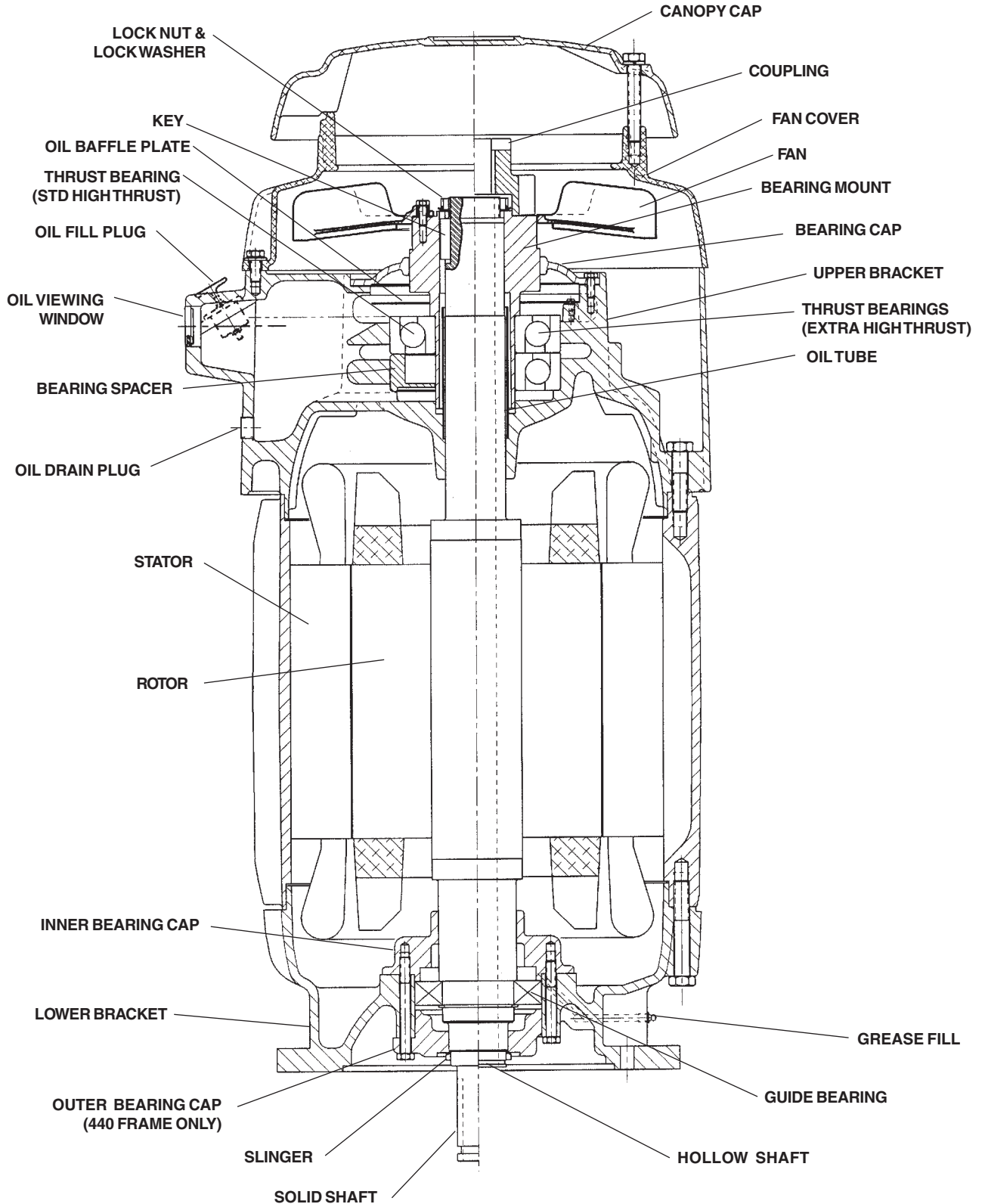

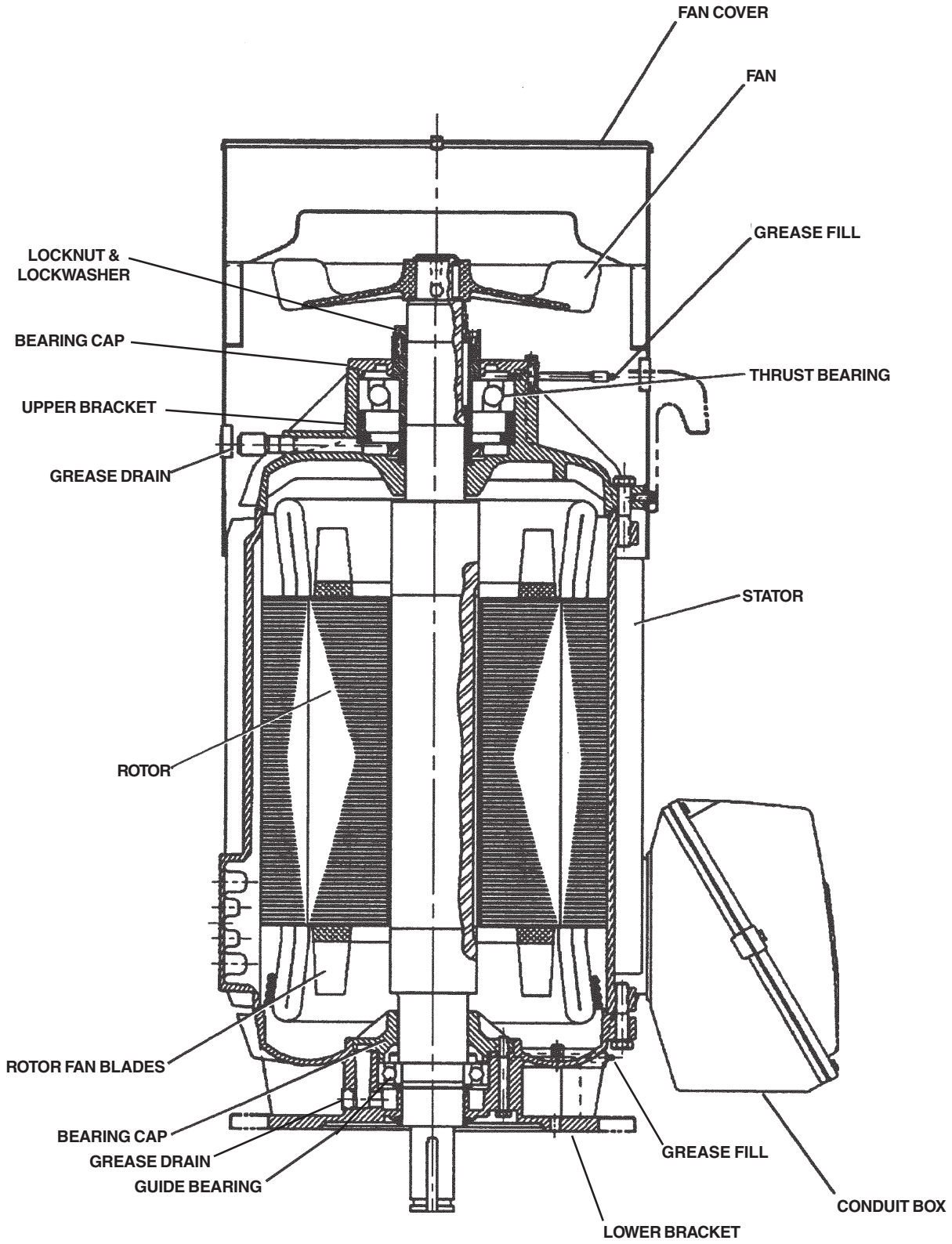



INSTALLATION AND MAINTENANCE

Spare Parts 449 Frame Type JV-4 (2 Pole)

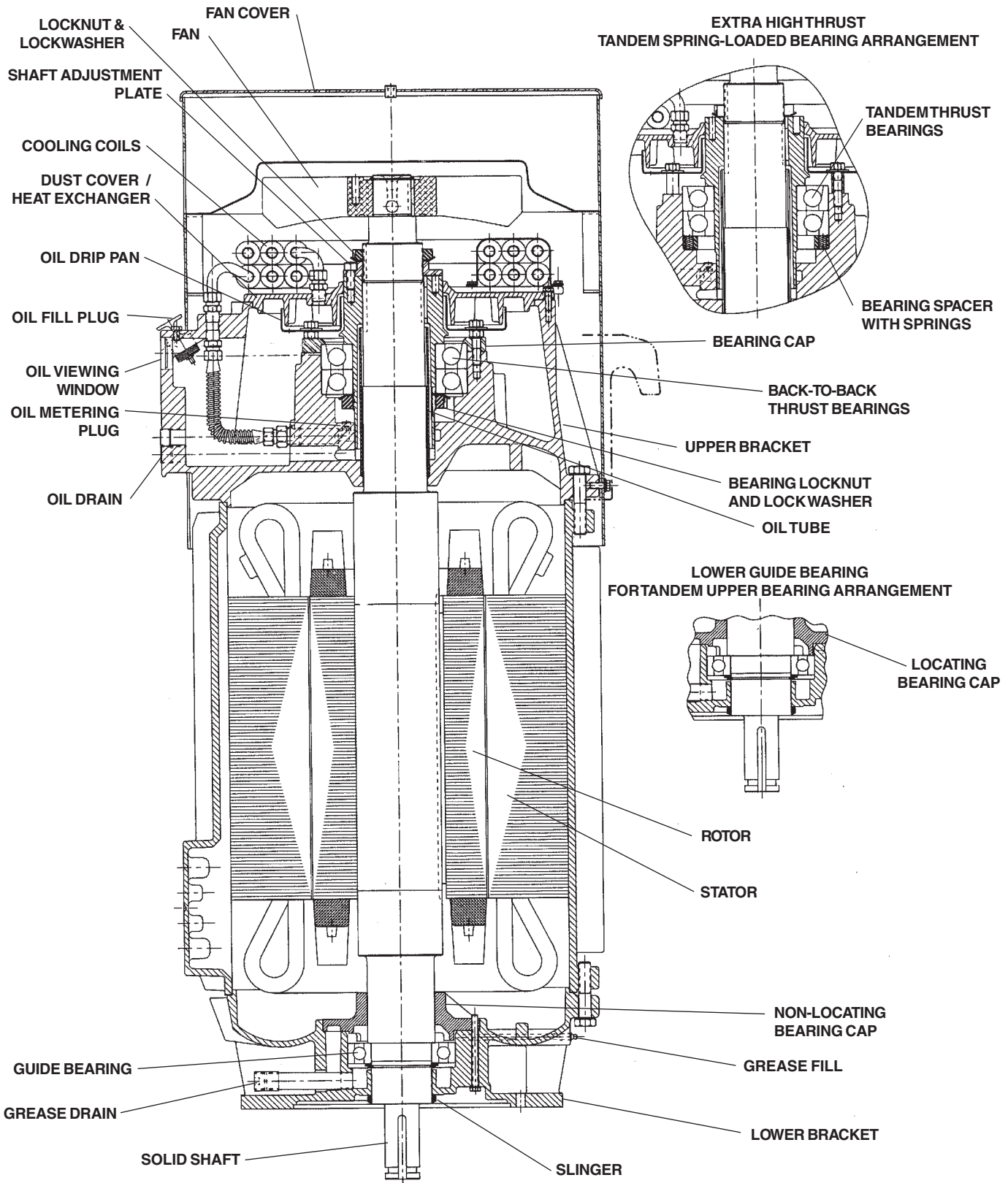



INSTALLATION AND MAINTENANCE

Spare Parts

449 Frame
Types JU and JV-4
(4 Pole & Slower)

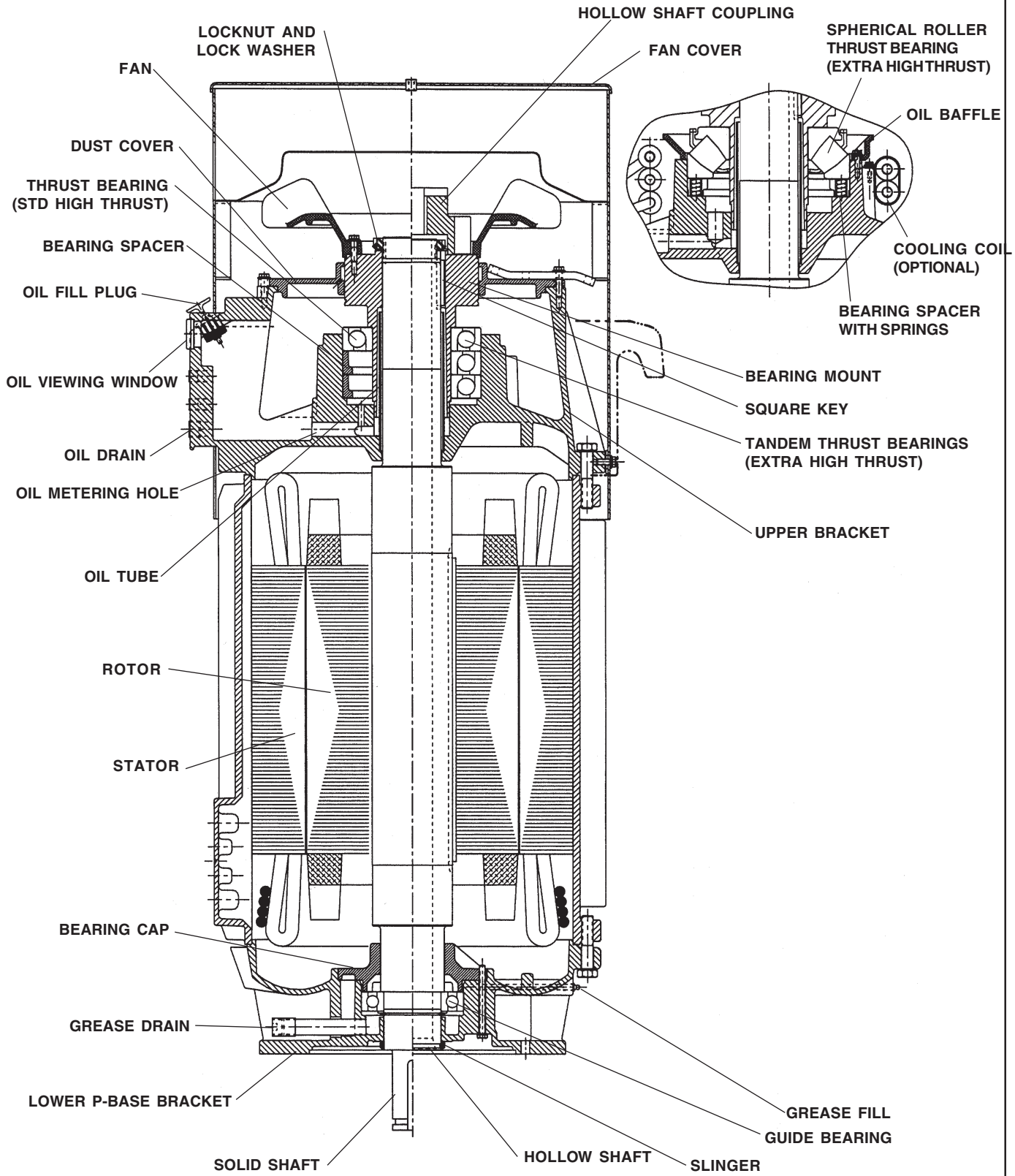



INSTALLATION AND MAINTENANCE

Spare Parts 5800 Frame Type JV-4 & EV-4 (2 Pole)

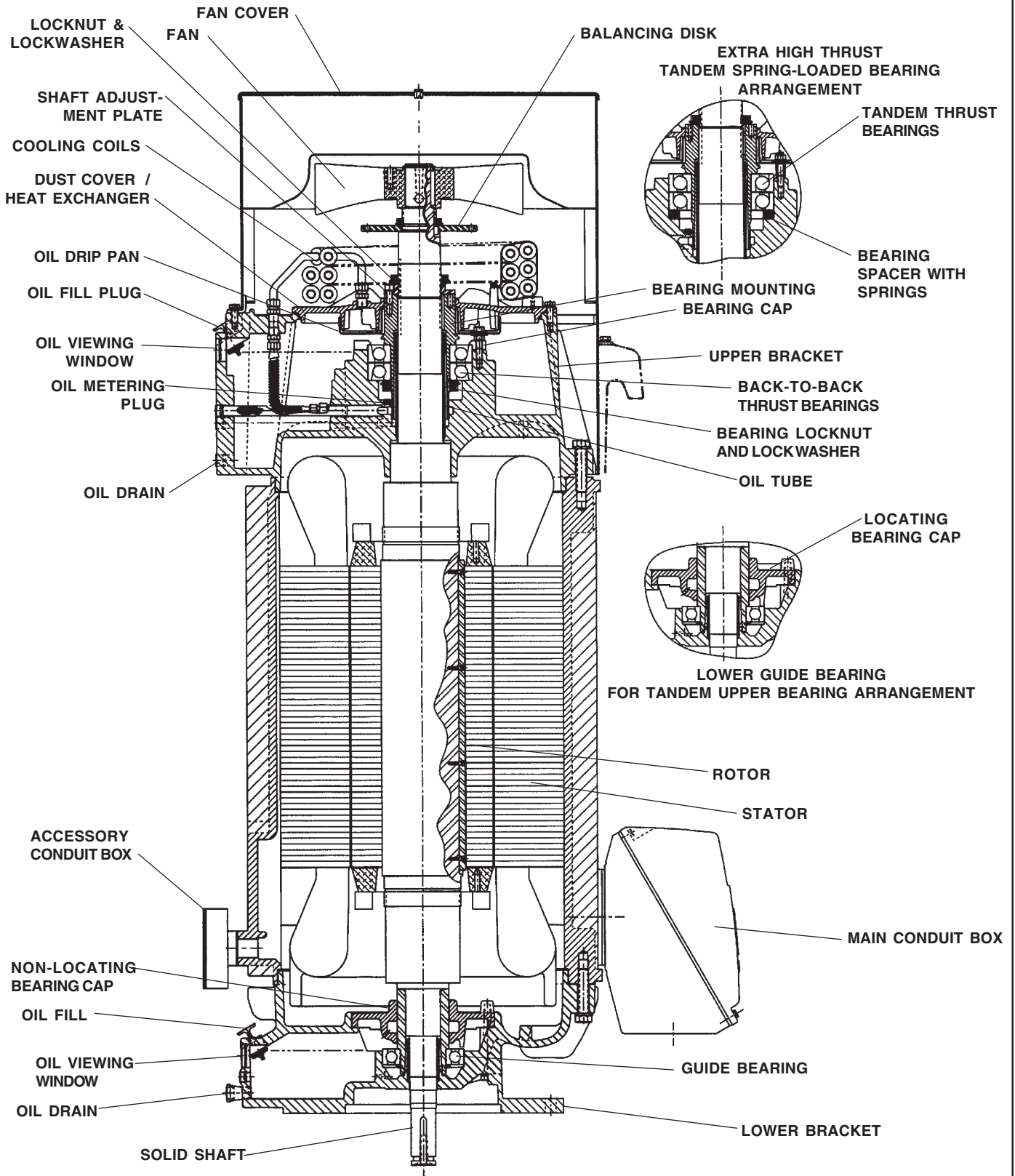



INSTALLATION AND MAINTENANCE

Spare Parts

5800 Frame
Types JU, JV-4, EU, EV-4
(4 Pole & Slower)

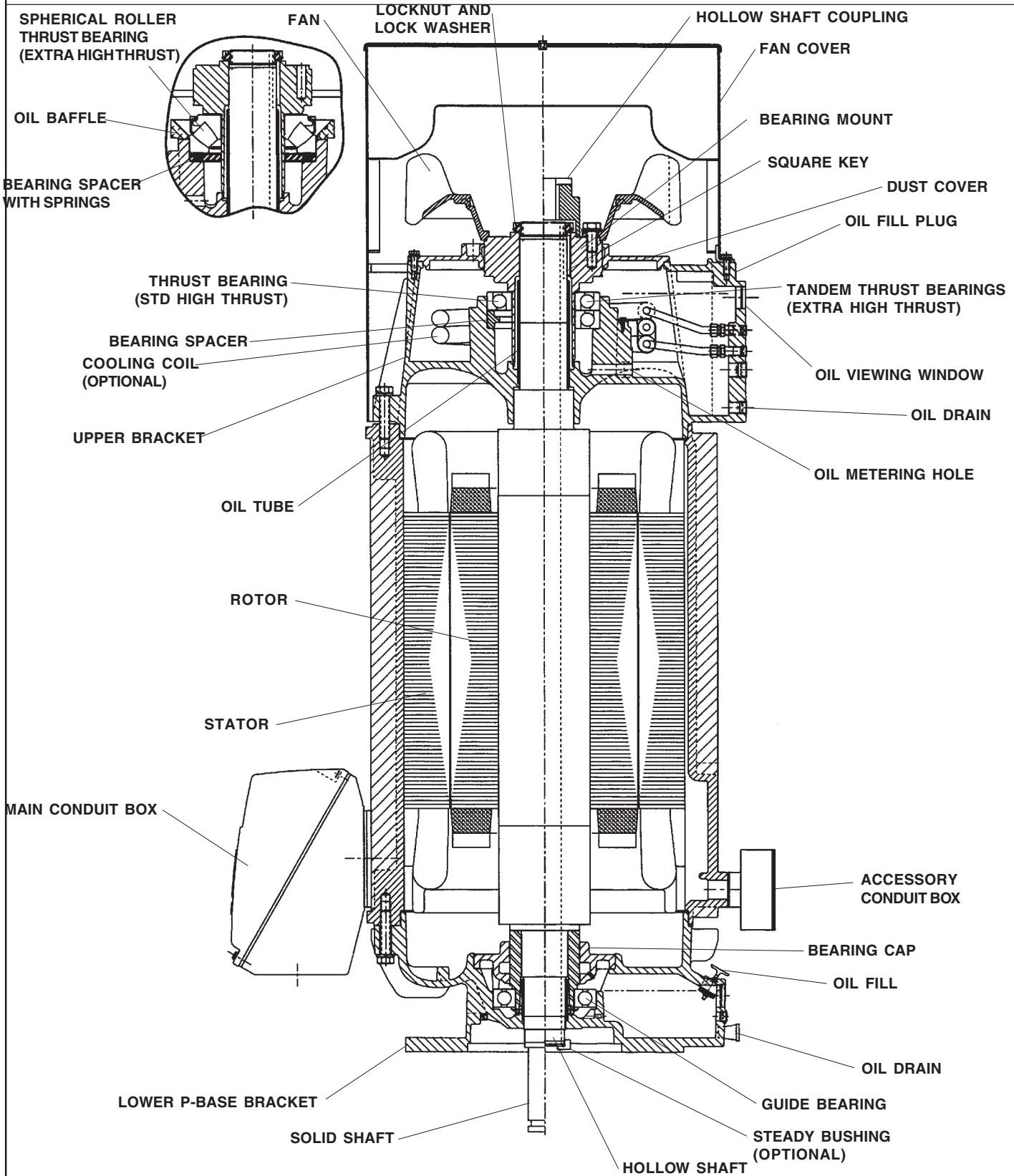



INSTALLATION AND MAINTENANCE

Spare Parts

5000-6800 Frame, Types HU&HV4
8000 Frame, Types RU&RV4
(4-Pole and Slower)

PUMP SHAFT, ADJUSTING NUT, AND LOCKING SCREWS
ARE FURNISHED BY CUSTOMER

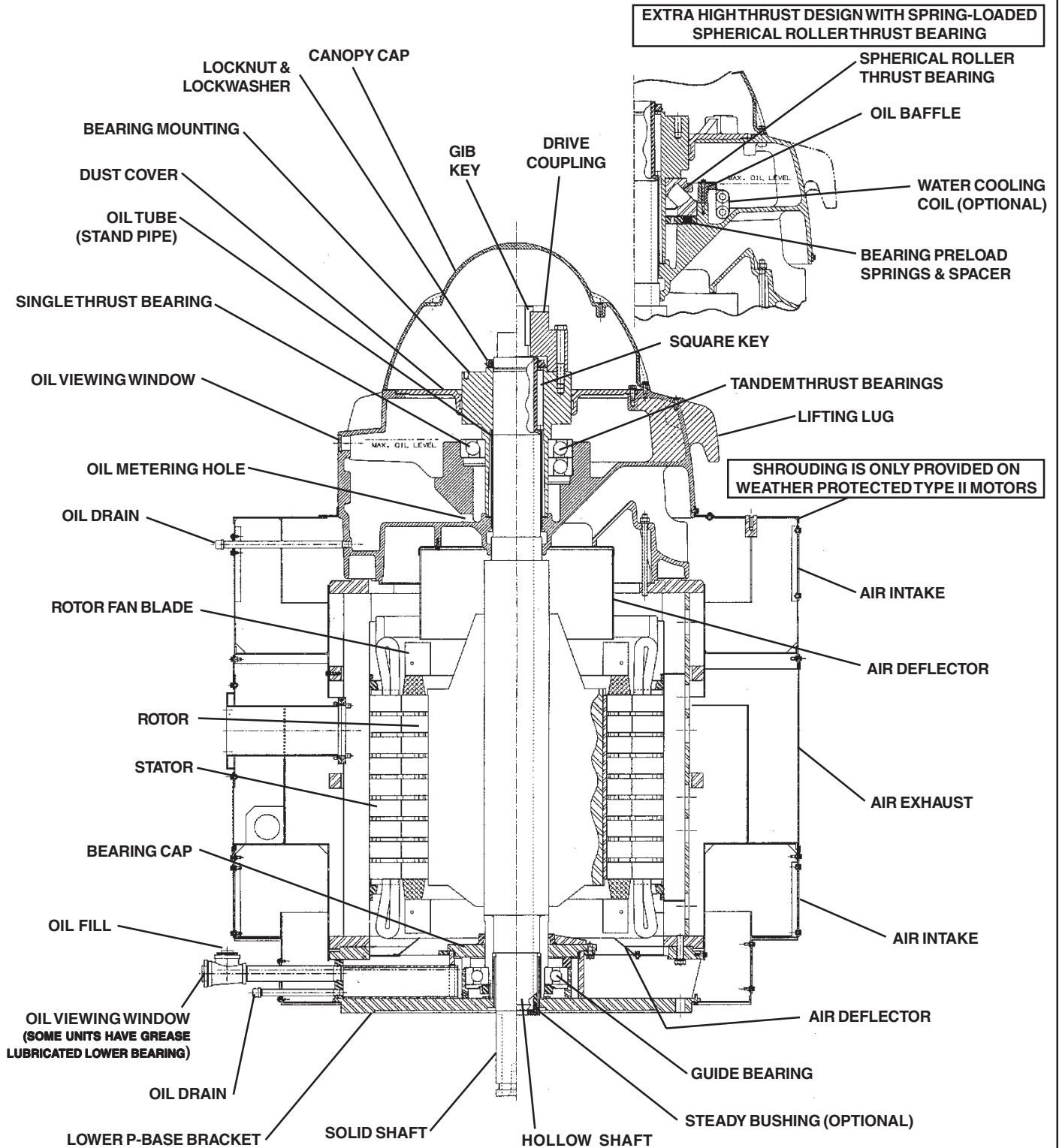



INSTALLATION AND MAINTENANCE

Spare Parts

5000 Frame
Types RU and RV-4

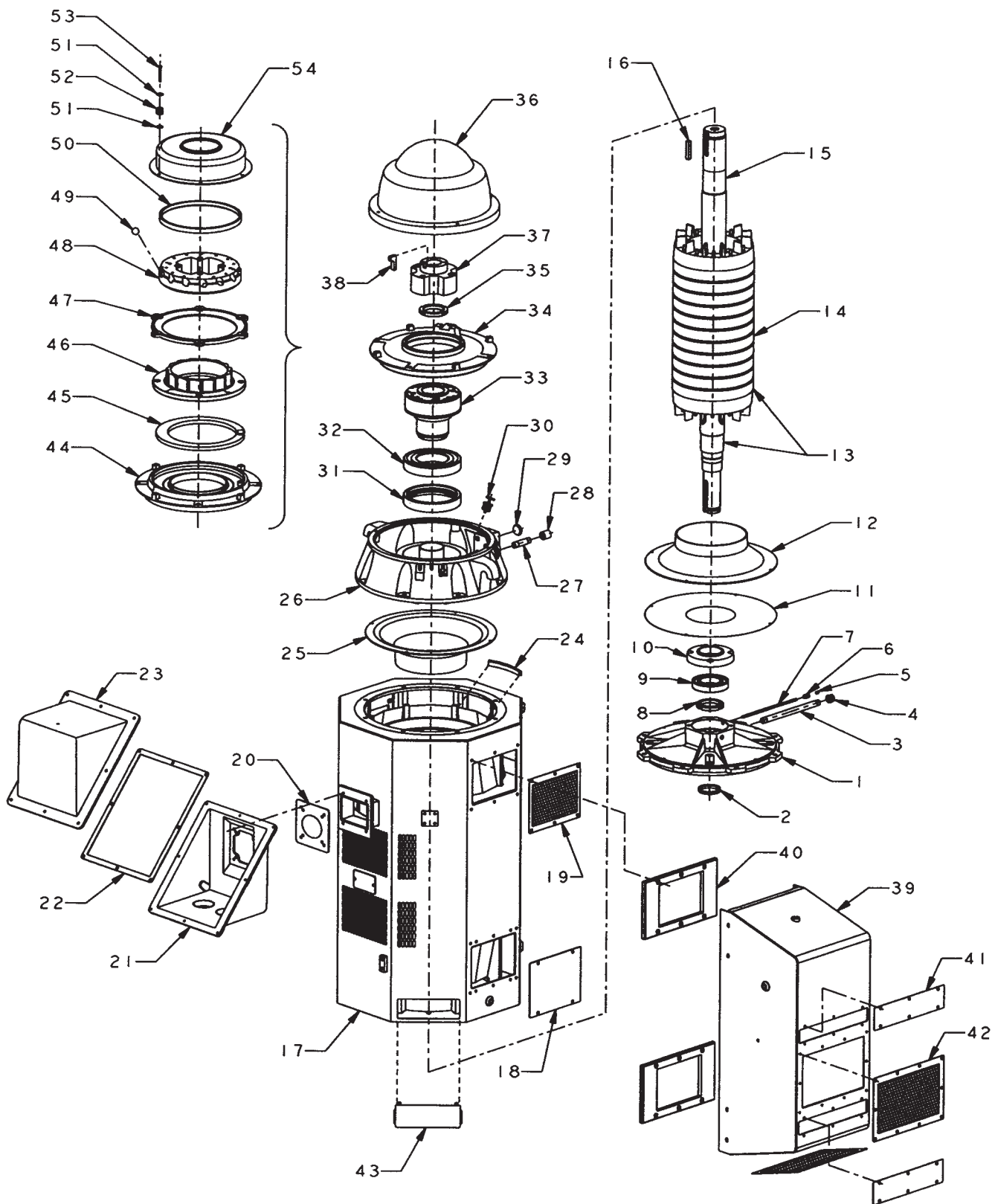



INSTALLATION AND MAINTENANCE

Spare Parts

5000 Frame
Types RU and RV-4

Item No.	Quantity	Name of Part	Remarks / Limitations
1	1	Lower Bracket	All Motors
2	1	Shaft Water Slinger	All Motors
3	1	Pipe Nipple (Lower Grease Drain)	All Motors
4	1	Pipe Cap (Lower Grease Drain)	All Motors
5	1	Grease Zerk Fitting	All Motors
6	1	Pipe Coupling (Lower Grease Fill)	All Motors
7	1	Pipe Nipple (Lower Grease Fill)	All Motors
8	1	Locknut and Lockwasher (Lower Bearing)	All Motors
9	1	Lower Bearing	All Motors
10	1	Lower Bearing Cap	All Motors
11	1	Lower Intake Screen	Only on WP-1
12	1	Lower Air Deflector	All Motors
13	1	Rotor Assembly	All Motors
14	1	Rotor Core	All Motors
15	1	Rotor Shaft	All Motors
16	1	Square Key (Bearing Mounting to Shaft)	All Motors
17	1	Stator Assembly	All Motors
18	2	Lower Air Intake Cover	Only on WP-1
19	2	Upper Air Intake Screen	Only on WP-1
20	1	Gasket (Outlet Box Base to Stator)	All Motors
21	1	Outlet Box Base	All Motors
22	1	Gasket (Outlet Box Cover to Base)	All Motors
23	1	Outlet Box Cover	All Motors
24	16	Grommet (Air Deflector to Frame Baffle)	All Motors - 8 on each end
25	1	Upper Air Deflector	All Motors
26	1	Upper Bracket	All Motors
27	1	Pipe Nipple (Oil Drain)	All Motors
28	1	Pipe Cap (Oil Drain)	All Motors
29	1	Oil Sight Gauge Window	All Motors
30	1	Oil Fill Plug (Expanding)	All Motors
31	1	Bearing Spacer (or Tandem Thrust Bearing)	All Motors
32	1	Upper Thrust Bearing	All Motors
33	1	Bearing Mounting	All Motors
34	1	Dust Cover	Only on Units Without Ratchet
35	1	Locknut and Lockwasher (Brg Mtg to Shaft)	All Motors
36	1	Canopy Cap	All Motors
37	1	Thrust Coupling	Only on Hollowshaft
38	1	Gib Key	Only on Hollowshaft
39	2	WP2 Intake Box	Only on WP-2
40	4	Adapter Flange	Only on WP-2
41	4	Filter Access Cover	Only on WP-2
42	4	Intake Screen	Only on WP-2
43	4	Cover (Flange Access)	Only on WP-2
44	1	Ratchet Adaptor	Only on Units With Ratchet
45	1	Connection Spring	Only on Units With Ratchet
46	1	Stationary Ratchet	Only on Units With Ratchet
47	1	Pressure Plate	Only on Units With Ratchet
48	1	Rotating Ratchet	Only on Units With Ratchet
49	12 (5008), 14 (5012)	Ratchet Ball	Only on Units With Ratchet
50	1	Ball Retaining Ring	Only on Units With Ratchet
51	4 (5008), 12 (5012)	Plain Washer	Only on Units With Ratchet
52	4 (5008), 6 (5012)	Die Spring	Only on Units With Ratchet
53	4 (5008), 6 (5012)	Screw	Only on Units With Ratchet
54	1	Pressurization Baffle	All Motors



INSTALLATION AND MAINTENANCE

Spare Parts 9600 Frame Types RU and RV-4

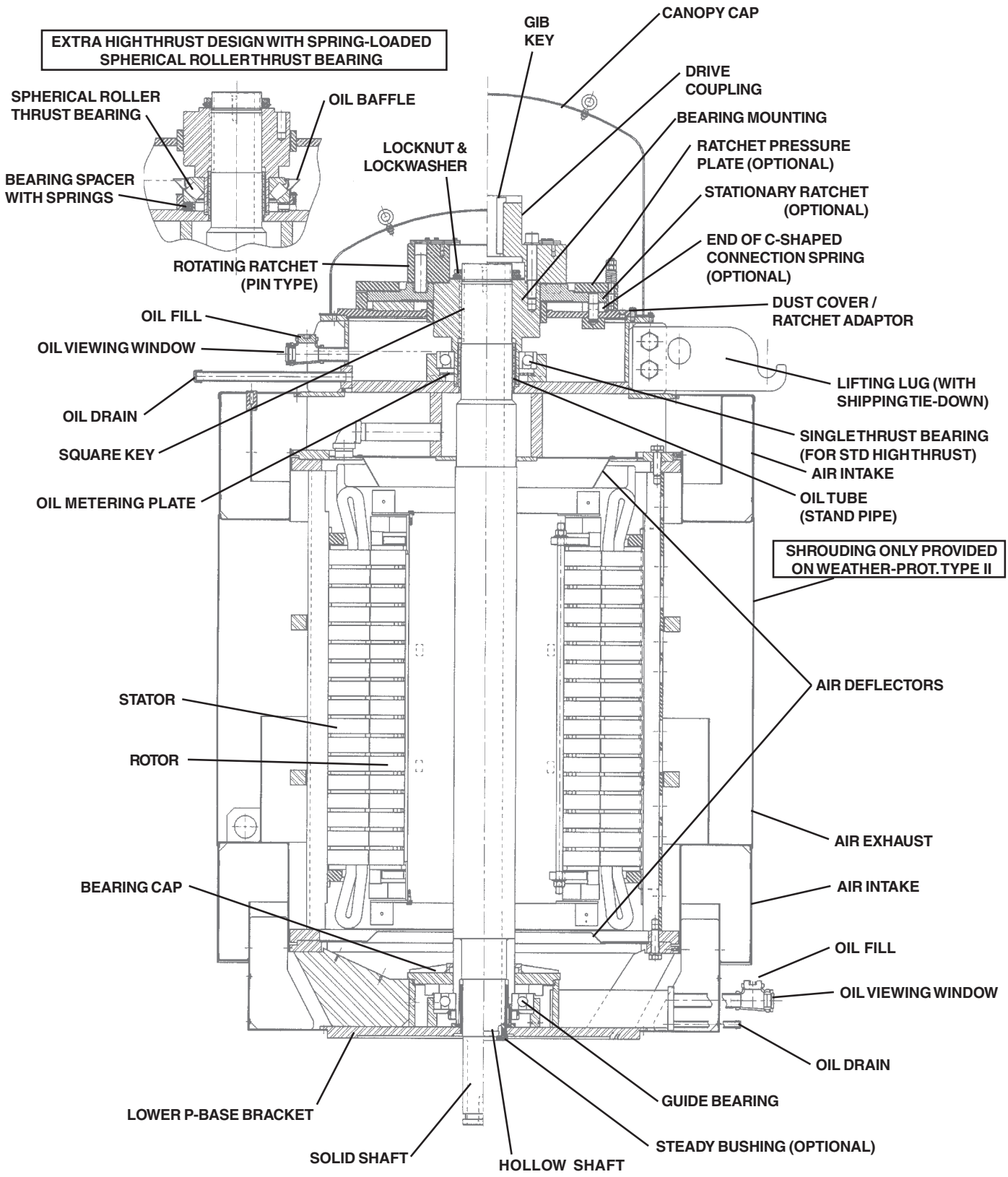



Table 6 Threaded Fastener Torque Requirements

All threaded fasteners used for rigid joints (cast iron and low carbon steel) in products of Emerson Motor Co., are to be tightened to the torque values listed in the following tabulation. Values are based upon dry assembly.

Table with 4 columns: Diameter of Fastener, Number of Threads Per Inch, Grade 5 Fasteners, and Grade 2 Fasteners. It lists torque requirements for various fastener sizes and thread counts.

The above torque limits are not to be used when a drawing or specification lists a specific torque.



Effects of Unbalanced Line Voltage.

A potential cause of premature motor failure is unbalanced line (supply) voltage. Three phase motors produce useful work when they efficiently convert electrical energy into mechanical energy. This is accomplished when each phase of the supply voltage is of equal strength and works in harmony to produce a rotating magnetic field within the motor.

When the value of supply voltage leg to leg is not equal (e.g. 460-460-460), the risk of unbalanced line voltage is present. If this voltage unbalance exceeds about 1%, excessive temperature rise will result. Unless the motor HP capacity is derated to compensate, the motor will run hot resulting in degradation of the insulation system and bearing lubricant.

From NEMA MG-1, 14.36: Derating factors due to unbalanced line voltage

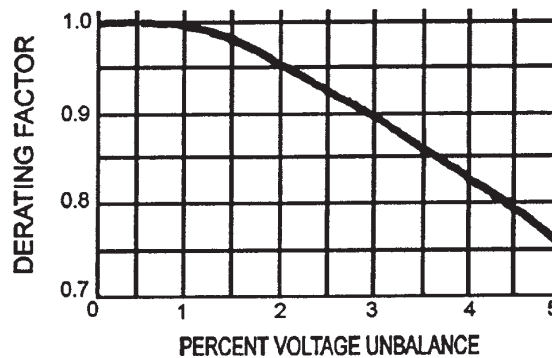

Example: Field ratings of Phase A - 480 v, Phase B = 460 v, Phase C = 450 v

As a rule of thumb, the percentage increase in temperature rise will be about two times the square of the percentage voltage unbalance. In this case the average voltage (480 + 460 + 450) is equal to 463 volts. The maximum deviation between legs is 17 volts (480 - 463 volts).

The Percentage voltage unbalance is determined as follows: $17 / 463 \times 100 = 3.7\%$. The temperature rise will then increase $(3.7)^2 \times 2 = 27\%$. This condition will reduce the typical life of your motor to less than 25% of its design life. Should this condition be present, call your electric utility and resolve your unbalanced supply condition.

Other areas of motor performance will also be effected - e.g., loss of torque capacity, change in full load RPM, greatly unbalanced current draw at normal operating speed. Refer to NEMA MG-1 section 14.36 for details.



Motors Applied to Variable Frequency Drives (VFD's).

Electric motors can be detrimentally affected when applied with variable frequency drives (VFD's). The non-sinusoidal waveforms of VFD's have harmonic content which causes additional motor heating; and high voltage peaks and short rise times, which result in increased insulation stress, especially when long power cable lengths are used. Other affects of VFD's on motor performance include reduced efficiency, increased load current, vibration and noise. Standard motors utilized with VFD's must be limited to those application considerations defined in NEMA MG-1 Part 30.

NEMA MG-1 Part 31 defines performance and application considerations for Definite-Purpose Inverter Fed motors. To insure satisfactory performance and reliability, Emerson Motor Co. offers and recommends nameplated inverter duty motor products which meet the requirements of NEMA MG-1 Part 31. The use of non-inverter duty motors may result in unsatisfactory performance or premature failure, which may not be warrantable under the Terms and Conditions of Sale. Contact your Emerson Motor Co. Field Sales Engineer for technical assistance in motor selection, application and warranty details.



ELECTRIC MOTOR LOAD TEST USING THE WATT HOUR METER

In the analysis of electric motors it is sometimes desirable to conduct an accurate load check on a particular installation to determine whether the motor is operating within the rating and horsepower for which it was designed. Since most pump installations have their own watt hour power meters, accurate readings will permit a load check via the following formula:

K = Disc constant (watts per revolution of disc per hour). This is typically found on the meter face.

R = Revolutions of disc in watt meter within the time of the test.

T = Time of test, in seconds.

Transformer ratio = Stated on meter face. Must be included where current transformers are used with watt meters.

To obtain input kilowatts: Input KW = (K x R x 3.6) / T

To obtain input horsepower: Input HP = (K x R x 4.83 x Transformer Ratio) / T

The watt hour meter measures power consumed over a period of time. It is necessary to establish the rate at which power is being consumed by the work being done. We establish this rate by counting the revolutions of the disc in a given time. Here is a typical example of a load check:

GIVEN

- Pump motor to be load checked is rated 100 HP, 1800 RPM, 3-phase, 60 Hz, 1.15 service factor, 91.0 Percent Efficiency.
• Disc constant (K) found on face of meter = 40.
• Transformer ratio found on face of meter = 3.

DATA FOUND FROM TESTS

With stop watch, disc was observed to revolve 10 times in exactly 49 seconds. Therefore, R = 10; T = 49.

THUS Input HP = (40 x 10 x 4.83 x 3) / 49 = 118.29

Output HP = Input HP x Motor Efficiency
Output HP = 118.29 x 91% = 107.54

CONCLUSION

The output HP (107.54) is greater than output HP shown on nameplate (100 HP), but is well within the 1.15 service factor which applies to this motor.

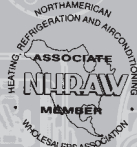

EMERSONTM
Motor Technologies