

MINCO
TT210, TT211, TT710, and TT711
2-wire Temperature Transmitters

Installation and Operating Instructions

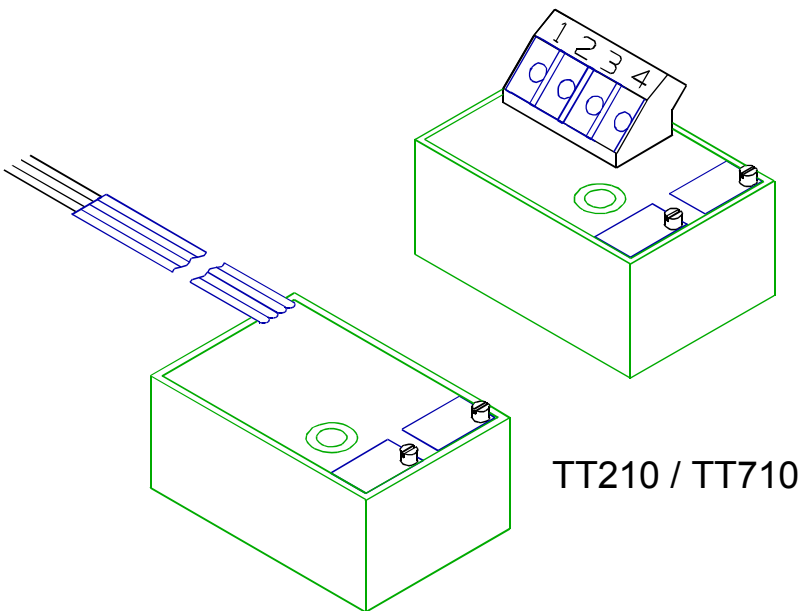

INTRINSICALLY SAFE
NON-INCENDIVE



TT211 / TT711

TT210 / TT710

MINCO PRODUCTS, INC.

7300 Commerce Lane, Minneapolis, MN 55432-3177 U.S.A.
Telephone: (763) 571-3121 / FAX: (763) 571-0927

Description

Models TT210, TT211, TT710, and TT711 are 2-wire temperature transmitters for 2-lead 100 ohm or 1000 ohm platinum RTD's. These transmitters are FM-approved for use in Class I, Divisions 1 & 2, Groups A, B, C, and D hazardous locations and appear in the approval guide as IS/1/1/ABCD and NI/1/2/ABCD. The Temptran™ converts the RTD's (resistance temperature detector's) signal into a current proportional to the RTD's temperature. The current changes according to the range marked on the Temptran: 4 mA at the lowest temperature of the range, rising to 20 mA at the top of the range. The leads that supply power also carry the current signal. Request Minco Application Aid 15 for more information.

Installation

If installing the Temptran in a hazardous location, the installer must adhere to installation requirements as set forth by the National Electrical Code (NEC) and any other applicable codes and standards. See pages 3 - 7 for further information on installing these transmitters in a hazardous location.

Locate the Temptran near the RTD, in an area where the ambient temperature stays between -25 and 85 °C (-13 and 185 °F). Mount with a #6 machine or #8 self-tapping screw.

Connect the Temptran as shown below, observing the +/- polarity of the current loop. Maximum DC supply voltage = 35 VDC. The RTD connections have no polarity. For the RTD, good connections are a must; a few ohms of resistance in the connection can cause an error of several degrees.

The Temptran has been factory-calibrated for its marked temperature range or else for a specific RTD. Do not change its zero and span adjustments.

Wiring Diagram

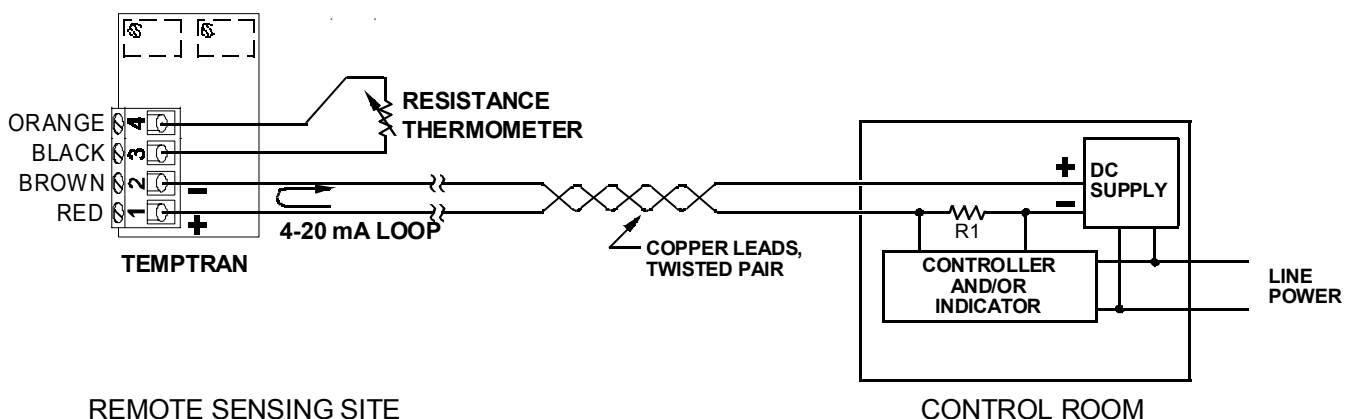

Installation of TT210, TT211, TT710, and TT711 Temptrans™ in Class I, Division 1 or 2, Groups A, B, C, and D hazardous locations.

Read these instructions thoroughly before installing transmitters.

Per Factory Mutual,

- 1) Installation shall be in accord with these instructions and the National Electric Code.
- 2) If installing in a Class I, Division 1 hazardous area, then refer to document INST. 704, "CONTROL DOCUMENT, SYSTEM APPROVALS FOR INTRINSICALLY SAFE TRANSMITTERS" on pages 5-7 of this manual. The Simple Apparatus, referenced in these pages, is the RTD temperature sensor or thermocouple.
- 3) If installing in a Class I, Division 2 hazardous area, then the transmitters must be mounted in a vent-free enclosure, meeting the "Electrical Utilization Enclosure Requirements" stated below with which only the Approved equipment will be installed. All unused openings should be sealed. Terminations of Model TT210 and TT710 transmitter field wiring must be made to a terminal strip, within the protective enclosure, that meets the spacing requirements found within ANSI/ISA Standard S82.01.
- 4) Tampering and replacement with non-factory components may adversely affect the safe use of the system.

Electrical Utilization Enclosure Requirements (Required for Division 2 areas only)

1. Each of the transmitters must be mounted within an enclosure to prevent personal injury resulting from accessibility to live parts. This enclosure must comply with the requirements listed below. Further details of the enclosure requirements may be found in ANSI/ISA Standards S82.01, S82.02, and S82.03.

1.1 Accessibility - The transmitters must be installed within the enclosure so that its circuits are accessible by the use of a tool only. A part is accessible when a) the IEC articulate accessibility probe applied in every possible position to the exterior or exposed surfaces, including the bottom, or b) the IEC rigid accessibility probe applied with a maximum force of 30 Newtons (6.75 lbs force) in every possible position to the exterior or exposed surface, including the bottom, touches the part.

1.2 Protection From Fire - If the enclosure is non-metallic, it shall have the proper flammability rating as detailed within ANSI/ISA Standard S82.01.

1.3 Grounding - A metallic enclosure must have a protective grounding terminal and be marked as such. The size of the ground terminal is to be equivalent to the size of the supply circuit conductor terminals. All accessible non-current conductive parts must be bonded to the protective grounding terminal.

1.4 General Construction - The equipment enclosure, or parts of the enclosure, required to be in place to comply with the requirements for protection from electric shock, personal injury, protection from internal parts and wiring, and external cord and cable assembly strain relief shall comply with the following tests for mechanical strength:

a. Impact Tests - The equipment shall be held firmly against a rigid support and shall be subjected to sets of three blows from a spring-operated impact hammer. The hammer shall be applied to any external part that when broken is likely to expose live parts. A window of an indicating device shall withstand an impact of 0.085 Newton-meter (0.753 pound force-inch) from a hollow steel impact sphere 50.8 mm (2 inches) in diameter and an approximate mass of 113.4 grams (4 ounces).

b. Pressure Tests - A force of 90 Newtons (20 pounds) shall be applied from a metal rod 12.7 mm (.50 inch) in diameter, the end of which is rounded. The force shall be applied for one minute to any point on the overall enclosure except the bottom. The bottom shall sustain a force of 65 Newtons (15 pounds).

c. Tip Stability Test - Equipment having a weight of 11 kilograms (24 pounds) or more shall not tip over when placed at the center of an inclined plane that makes an angle of 10 degrees with the horizontal and then turned to the position (with all doors, drawers and other openable and sliding parts in the least stable position) most likely to cause tip-over.

d. Sharp Edges - An accessible edge, projection, or corner of an enclosure, opening, frame, guard, handle, or the like shall be smooth and well rounded, and shall not cause a cut-type injury during normal use of the equipment.

REVISIONS				
REV.	DESCRIPTION	DATE	ECO	APP.
A	ADDED NOTES 2-8, WAS INST 702(-), ADDED "SIMPLE APPARATUS" NOTES	6/14/93	10344	MWG

INST. 704(A)

Control Document, System Approvals for Intrinsically Safe Transmitters

ANY CHANGES TO THIS
 DRAWING MUST BE
 PREAPPROVED BY FACTORY
 MUTUAL PER INST. 695

The approved entity parameters specified are for Class I, Div. 1 Groups A, B, C, and D hazardous locations.

Models	Models	Models
TT210, TT211	TT176, TT216, TT676	
TT710, TT711	TT190, TT230	TT220, TT221, TT720
Vmax = 35 volts	Vmax = 35 volts	Vmax = 35 volts
I _{max} = 150 Ma	I _{max} = 150 mA	I _{max} = 150 mA
C _i = 0 μF	C _i = 0 μF	C _i = 0 μF
L _i = 0 mH	L _i = 0 mH	L _i = 0 mH

1. The selected associated apparatus and intrinsically safe apparatus must meet the following conditions for single channel operation:

$$\begin{aligned} V_{oc} &\leq V_{max} \\ I_{sc} &\leq I_{max} \\ C_a &\geq C_i \\ L_a &\geq L_i \end{aligned}$$

2. The selected associated apparatus and intrinsically safe apparatus must meet the following conditions for dual channel or multiple single channel operation:

$$\begin{aligned} V_t &\leq V_{max} \\ I_t &\leq I_{max} \\ C_a &\geq C_i \\ L_a &\geq L_i \end{aligned}$$

3. V_{oc} , V_t , I_{sc} , I_t , C_a and L_a are parameters of the associated apparatus where:

V_{oc}, V_t = maximum open circuit voltage
 I_{sc}, I_t = maximum short circuit current
 C_a = maximum allowable connected capacitance
 L_a = maximum allowable connected inductance

4. V_{max} , I_{max} , C_i and L_i are parameters of the intrinsically safe apparatus where:

V_{max} = maximum safe input voltage
 I_{max} = maximum safe input current
 C_i = maximum unprotected internal capacitance
 L_i = maximum unprotected internal inductance

5. Installation must be in accordance with the barrier manufacturers instructions, ANSI/ISA RP12.6 and the National Electrical Code (ANSI/NFPA 70).

6. Control room equipment connected to the associated apparatus must not contain a source of potential with respect to earth in excess of 250 V_{rms} or 250 V_{dc}.

7. Associated apparatus is not required for operation in Division 2 hazardous (classified) locations.

8. For Division 2 installations, the transmitters must be mounted within an enclosure meeting the requirements of ANSI/ISA S82.

DR: <u>TPB</u>	CHK: <u>MWG</u>	APP: <u>DKS</u>
DATE: <u>05/04/93</u>	<u>05/05/93</u>	<u>05/05/93</u>
F:\MOD\TT176\LIT\704.DOC		10/29/01 DKS

ANY OF THE LISTED INTRINSIC SAFETY BARRIERS ARE FACTORY MUTUAL APPROVED UNDER THE SYSTEM CONCEPT (SINGLE BARRIER ONLY) FOR USE WITH ANY OF THE FOLLOWING MINCO TEMPTRAN™ 4-20mA TRANSMITTER MODELS:

TT176, TT190, TT210, TT211, TT216, TT220,
 TT221, TT230, TT676, TT710, TT711, TT720

FOR USE IN CLASS I, DIVISION 1, GROUPS A, B, C, D HAZARDOUS LOCATIONS.

<u>BARRIER MANUFACTURER</u>	<u>BARRIER MODEL</u>	
MTL (MANASSAS, VA 703-361-0111)	702+	
	706+	
	787S+	
	788+	
	2441	
	3041	
	3046B	
	4041	
	R. STAHL (WOBURN, MA 800-782-4357)	9001/01-280-100-10
		9001/51-280-091-14
9001/51-280-110-14		
9002/13-280-110-00		
PEPPERL & FUCHS (TWINSBURG, OH 216-425-3555)	KHD3-ICR/EX130 200	
	KHD3-ICR/EX130 240	
	KHP-103/EX-1A	
	KHP-104/EX-2A	
	KHP-105/EX-2A	
	KHZ-428/EX3	
	KHZ-487/EX3	
	KHZ-907/EX	
	Z130/EX	
	Z428/EX	
	Z479/EX	
Z487/EX		

ANY CHANGES TO THIS
 DRAWING MUST BE
 PREAPPROVED BY FACTORY
 MUTUAL PER INST. 695

HAZARDOUS AREA
 CLASS I, DIVISION 1 OR 2,
 GROUPS A, B, C, AND D

NON-HAZARDOUS AREA

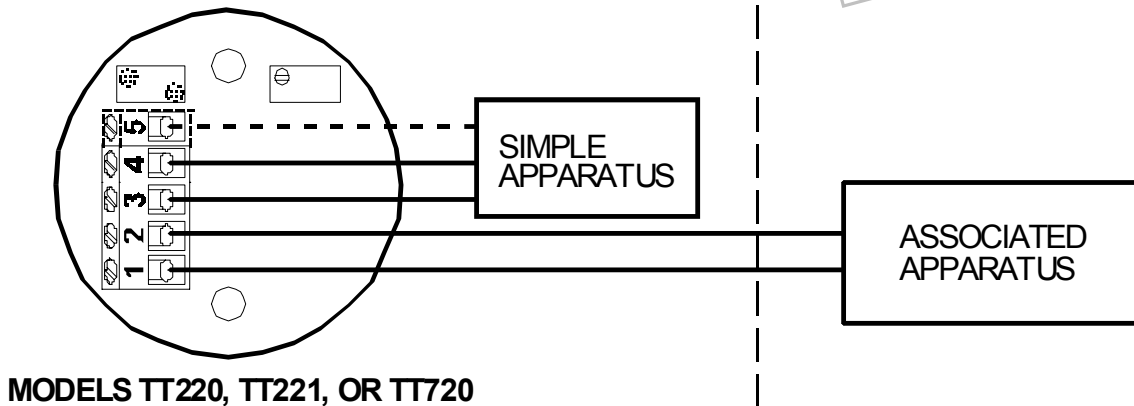
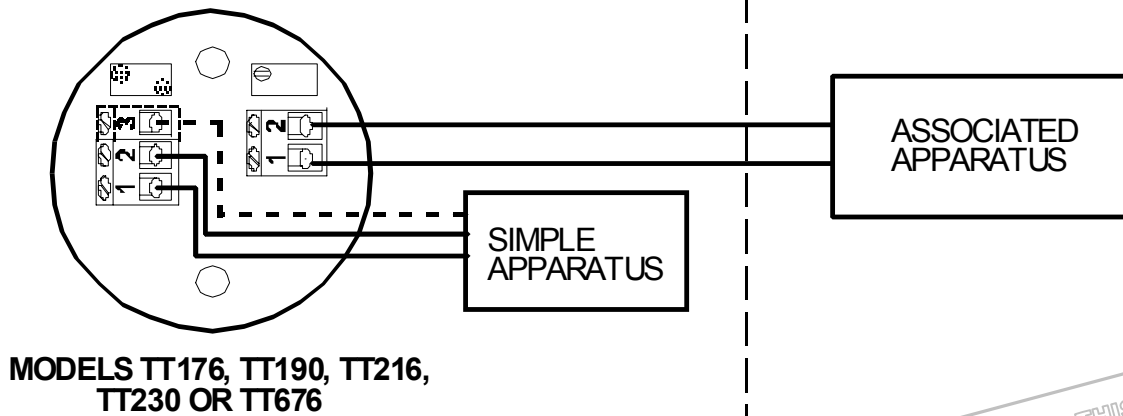
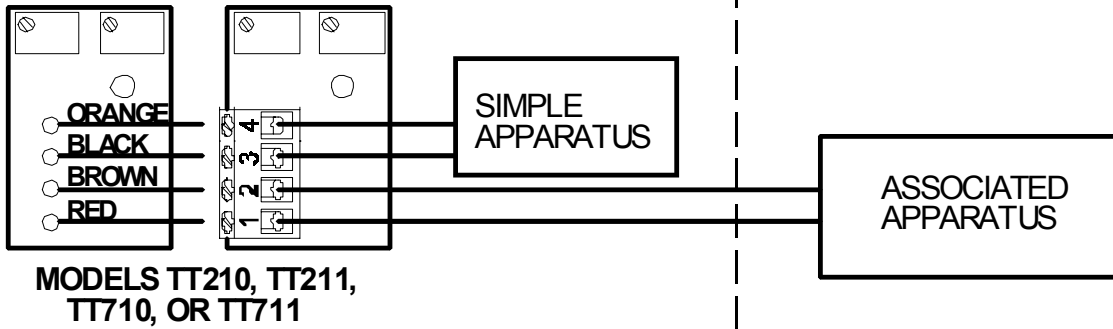

ANY CHANGES TO THIS
 DRAWING MUST BE
 PREAPPROVED BY FACTORY
 MUTUAL PER INST. 695

Calibration

1. Connect a power supply of 24 VDC and a digital milliammeter (5-1/2 digit preferred) as shown in the figure, or use a loop calibrator instead of the DC supply and milliammeter.

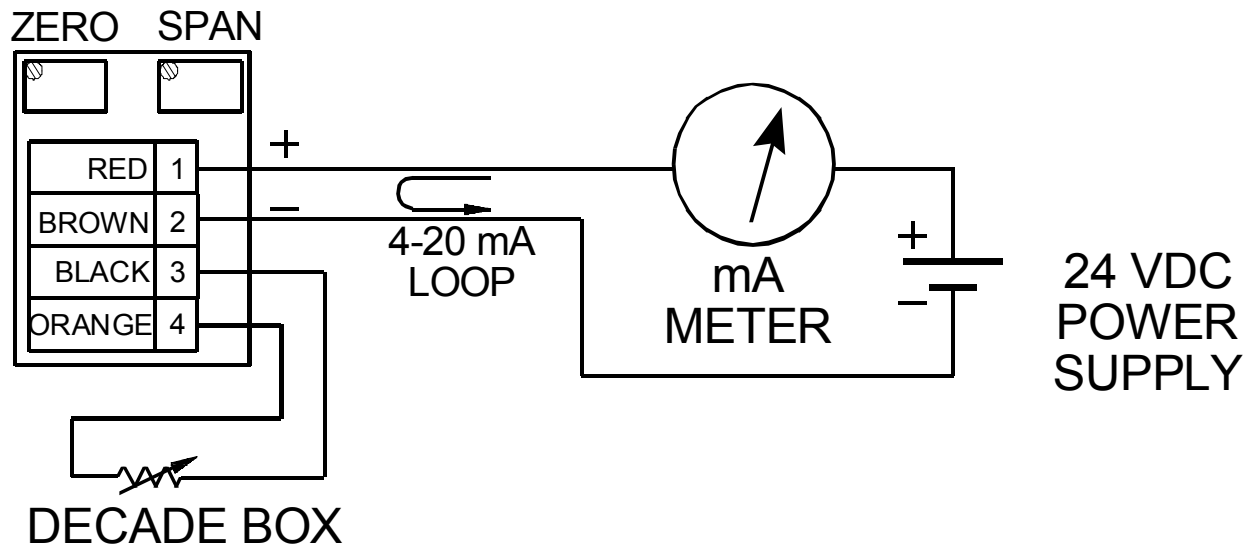

NOTE: Zero and Span resistance values are printed on the transmitter's label.

2. Connect a resistance decade box with a resolution of at least .01 ohms to the input of the transmitter. If unsure or concerned about the decade box's accuracy, measure the zero and span resistance setting, using a known-accurate ohmmeter and record decade box settings before connecting decade box to the transmitter.
3. Set decade box resistance to simulate the 4 mA temperature.
4. Adjust ZERO potentiometer on the transmitter until the meter reads 4 mA.
5. Set decade box resistance to simulate the 20 mA temperature.
6. Adjust SPAN potentiometer on the transmitter until the meter reads 20 mA.
7. Repeat steps 3 - 7 until no further adjustment is necessary.

Warranty

Items returned within one year from the date of sale, transportation prepaid, which Minco Products, Inc. (The "Seller") reasonably determines to be faulty by reason of defective materials or faulty workmanship will be replaced or repaired at the Seller's discretion, free of charge.

This remedy is to be the sole and exclusive remedy available to the buyer in the event of a breach by the Seller. Items that show evidence of mishandling or misapplication may be returned by the Seller at the customer's expense.

Furthermore, the Seller is not to be held responsible for consequential damages caused by its product except as required under Minnesota Statutes, Section 336.1-719 (3).

This warranty is expressly in lieu of any other expressed warranty or implied warranty of merchantability or fitness for a particular purpose, and of any other obligations or liability on the part of the Seller or its employees or agents.

Specifications

Input: 100 Ω or 1000 Ω platinum 2-lead RTD.

Output: 4 to 20 mA DC over specified range.

Accuracy: +/- 0.1% of span.

Linearity: +/- 0.1% of span.

Adjustments: Zero and Span, +/- 5% of span.

Ambient Temperature:

Operating: -25 to 85 $^{\circ}\text{C}$ (-13 to 185 $^{\circ}\text{F}$).

Storage: -55 to 100 $^{\circ}\text{C}$ (-67 to 212 $^{\circ}\text{F}$).

Ambient Temperature Effects:

+/- 0.007% of span/ $^{\circ}\text{F}$ (+/- 0.013% of span/ $^{\circ}\text{C}$).

+/- 0.014% of span/ $^{\circ}\text{F}$ for spans less than 20 Ω .

Warmup Drift: +/- 0.1% of span max., assuming $V_{\text{supply}} = 24 \text{ VDC}$ and $R_{\text{loop}} = 250 \text{ ohms}$. Stable within 30 minutes.

Supply Voltage: 8.5 to 35 volts DC with no load. Reverse polarity protected.

Voltage effect: +/- 0.001% of span per volt.

Maximum Load Resistance: The maximum allowable resistance of the signal-carrying loop is given by this formula: $R_{\text{loop max}} = (V_{\text{supply}} - 10) / .02 \text{ amps}$.

Maximum Output Current: 27 mA.

Connections:

TT210/TT710: Four AWG 22 leads, 5" long.

TT211/TT711: Terminal blocks for wires from AWG 22 to AWG 14.

Physical: Epoxy potted for moisture resistance.

Weight: 1.1 oz. (30 grams).

Model Number Coding:

TT210 PD 1 C . . . Sample part number

Temperature Range: Use one of the over 175 range codes in the MINCO Temptran sales bulletin. Note: A range that is available for a particular Temptran model is not automatically available for the TT210/TT211/TT710/TT711; there may be a nominal charge.

Output: 1 = 4 to 20 mA DC.

Calibrated to match RTD Element Code:

PA = 100 ohm platinum (.00392)

PB = 100 ohm platinum (.00391)

PD = 100 ohm platinum (.00385, meets DIN 43760, Class B)

PE = 100 ohm platinum (.00385)

PF = 1000 ohm platinum (.00385)

PW = 1000 ohm platinum (.00375)

Model Number: TT210, TT211 RTD Temptran
TT710, TT711 Temptran Calibrated to a specific RTD

This page intentionally left blank.

This page intentionally left blank.

When quality and performance are as important as price, call...

MINCO PRODUCTS, INC.

7300 Commerce Lane, Mpls., MN 55432-3177
Telephone: (763) 571-3121 FAX: (763) 571-0927

Stock No. 360-00052
Minco Form# 960212

©2001 MINCO PRODUCTS, INC.
G:\MOD\TT210\Lit\509.doc
10/29/01 DKS