

ABB industrial drives

Hardware manual

ACS880-07 drives

(45 to 710 kW, 50 to 700 hp)



List of related manuals

Drive hardware manuals and guides

Code (English)

<i>ACS880-07 hardware manual</i>	3AUA0000105718
<i>ACS-AP-X assistant control panels user's manual</i>	3AUA0000085685
<i>ACS880-07 lifting device user's manual</i>	3AUA0000131337

Drive firmware manuals and guides

<i>ACS880 primary control program firmware manual</i>	3AUA0000085967
<i>Quick start-up guide for ACS880 drives with primary control program</i>	3AUA0000098062

Option manuals and guides

<i>Drive composer start-up and maintenance PC tool user's manual</i>	3AUA0000094606
<i>FSO-12 safety functions module user's manual</i>	3AXD50000015612
<i>User's manual for Prevention of unexpected start-up (+Q950) for ACS880-07/17/37 drives</i>	3AUA0000145922
<i>User's manual for Emergency stop, stop category 0 (+Q951) for ACS880-07/17/37 drives</i>	3AUA0000119895
<i>User's manual for Emergency stop, stop category 1 (+Q952) for ACS880-07/17/37 drives</i>	3AUA0000119896
<i>User's manual for Prevention of unexpected start-up (+Q957) for ACS880-07/17/37 drives</i>	3AUA0000119910
<i>User's manual for Emergency stop, stop category 0 (+Q963) for ACS880-07/17/37 drives</i>	3AUA0000119908
<i>User's manual for Emergency stop, stop category 1 (+Q964) for ACS880-07/17/37 drives</i>	3AUA0000119909
<i>User's manual for Emergency stop, configurable stop category 0 or 1 (+Q978) for ACS880-07/17/37 drives</i>	3AUA0000145920
<i>User's manual for Emergency stop, configurable stop category 0 or 1 (+Q979) for ACS880-07/17/37 drives</i>	3AUA0000145921

You can find manuals and other product documents in PDF format on the Internet. See section [Document library on the Internet](#) on the inside of the back cover. For manuals not available in the Document library, contact your local ABB representative.

The code below opens an online listing of the manuals applicable to this product.



[ACS880-07 manuals](#)

Hardware manual

ACS880-07 drives
(45 to 710 kW, 50 to 700 hp)





Table of contents	
1. Safety instructions	
4. Mechanical installation	
6. Electrical installation	
10. Start-up	

Table of contents

1. Safety instructions

Contents of this chapter	13
Use of warnings	13
General safety in installation, start-up and maintenance	14
Electrical safety in installation, start-up and maintenance	16
Precautions before electrical work	16
Additional instructions and notes	17
Grounding	18
Additional instructions for permanent magnet motor drives	19
Safety in installation, start-up and maintenance	19

2. Introduction to the manual

Contents of this chapter	21
Target audience	21
Contents of the manual	21
Related manuals	22
Categorization by frame size and option code	22
Quick installation, start-up and operating flowchart	22
Terms and abbreviations	23

3. Operation principle and hardware description

Contents of this chapter	25
Product overview	25
Single-line circuit diagram of the drive	26
Block diagram of the brake and DC options (+D150, +D151 and +H356)	27
General information on the cabinet layout	28
Cabinet layout of frames R6 to R8	29
Cabinet layout of frames R6 to R8 with option +C129	30
Cabinet layout of frames R6 to R8 with options +C129 and +F289	31
Cabinet layout of frame R9	33
Cabinet layout of frame R9 with options +C129 and +F289	35
Cabinet layout of frames R10 and R11 – bottom entry and exit of cables	37
Cabinet layout of frames R10 and R11 – top entry and exit of cables (option +C129)	39
Overview of power and control connections	40
Door switches and lights	42
Main switch-disconnector Q1	42
Control panel	43
Control by PC tools	43
Descriptions of cabinet options	43
Degree of protection	43
Definitions	43
IP22 and UL Type 1 (standard)	43
IP42 and UL Type 1 Filtered (option +B054)	44
IP54 and UL Type 12 (option +B055)	44
Channeled air inlet through bottom (option +C128)	44



Channeled air outlet (option +C130)	44
Marine construction (option +C121)	44
UL listed (option +C129)	45
CSA approved (option +C134)	45
Plinth height (options +C164 and +C179)	45
Seismic design (option +C180)	45
Resistor braking (options +D150 and +D151)	45
EMC filters (options + E200, +E201, +E202, +E210)	45
du/dt filter (option +E205)	45
Sine filter (option +E206)	46
Common mode filter (option +E208)	46
Cabinet heater with external supply (option +G300)	46
Terminals for external uninterruptible control voltage (option +G307)	46
Output for motor space heater (option +G313)	47
Additional wire markings (options +G340 and +G342)	47
US/UK gland/conduit plate (option +H358)	47
Additional terminal block X504 (option +L504)	47
Thermistor relays (options +L505, +2L505)	48
Pt100 relays (options +3L506, +5L506, +8L506)	48
What the option contains	48
Description	48
Type designation label	49
Type designation key	49

4. Mechanical installation

Contents of this chapter	55
Examining the installation site	55
Necessary tools	56
Moving and unpacking the drive	57
Unpacking the transport package	58
Checking the delivery	58
Moving the drive cabinet	58
Installing the IP54 roof	59
Frames R6 to R8	59
Frame R9	60
Frames R10 and R11	61
Lifting the drive cabinet	62
Moving the cabinet on rollers	63
Final placement of the cabinet	63
Fastening the cabinet to the floor and wall or roof (non-marine units)	64
General rules	64
Fastening methods	65
Alternative 1 – Clamping	65
Alternative 2 – Using the holes inside the cabinet	65
Fastening the cabinet to the floor and roof/wall (marine units)	66
Miscellaneous	67
Cable duct in the floor below the cabinet	67
Air inlet through the bottom (option +C128+B055)	67
Air outlet duct on the cabinet roof (option +C130)	68
Calculating the required static pressure difference	68
Arc welding	69

5. Guidelines for planning the electrical installation

Contents of this chapter	71
Limitation of liability	71
Selecting the supply disconnecting device	71
Selecting the main contactor	71
Examining the compatibility of the motor and drive	72
Protecting the motor insulation and bearings	72
Requirements table	73
Additional requirements for explosion-safe (EX) motors	74
Additional requirements for ABB motors of types other than M2_, M3_, M4_, HX_ and AM_	75
Additional requirements for the braking applications	75
Additional requirements for ABB high-output and IP23 motors	75
Additional requirements for non-ABB high-output and IP23 motors	76
Additional data for calculating the rise time and the peak line-to-line voltage	77
Additional note for sine filters	77
Selecting the power cables	78
General rules	78
Typical power cable sizes	79
Alternative power cable types	80
Recommended power cable types	80
Power cable types for limited use	80
Not allowed power cable types	81
Motor cable shield	81
Additional US requirements	81
Conduit	81
Armored cable / shielded power cable	81
Planning the braking system	82
Selecting the control cables	82
Shielding	82
Signals in separate cables	82
Signals allowed to be run in the same cable	82
Relay cable type	82
Control panel cable length and type	82
Routing the cables	83
Separate control cable ducts	83
Continuous motor cable shield or enclosure for equipment on the motor cable	83
Implementing thermal overload and short-circuit protection	84
Protecting the drive and input power cable in short-circuits	84
Protecting the motor and motor cable in short-circuits	84
Protecting the drive and the input power and motor cables against thermal overload	85
Protecting the motor against thermal overload	85
Protecting the drive against ground faults	85
Residual current device compatibility	85
Implementing the emergency stop function	85
Implementing the Safe torque off function	86
Implementing Prevention of unexpected start-up function	86
Implementing the functions provided by the FSO-xx safety functions module (option +Q972 or +Q973)	86
Declaration of Conformity	86
Implementing the Power-loss ride-through function	87
Units with main contactor (option +F250)	87



Supplying power for the auxiliary circuits	87
Using power factor compensation capacitors with the drive	87
Implementing a safety switch between the drive and the motor	88
Using a contactor between the drive and the motor	88
Implementing a bypass connection	89
Example bypass connection	89
Switching the motor power supply from drive to direct-on-line	90
Switching the motor power supply from direct-on-line to drive	90
Protecting the contacts of relay outputs	90
Connecting a motor temperature sensor to the drive I/O	91

6. Electrical installation

Contents of this chapter	93
Warnings	93
Checking the insulation of the assembly	93
Drive	93
Input cable	93
Motor and motor cable	94
Brake resistor assembly	94
Checking the compatibility with IT (ungrounded) systems	94
Attaching the device stickers on the cabinet door	95
Connecting the power cables	96
Connection diagram	96
Layout of the power cable connection terminals and lead-throughs (frames R6 to R8)	97
Layout of the power cable connection terminals and lead-throughs (frames R6 to R8 with option +C129)	98
Layout of the power cable connection terminals and lead-throughs (frames R6 to R8 with options +C129+F277+F289)	99
Layout of the input and motor cable connection terminals (frame R9)	100
Layout of the power cable connection terminals and lead-throughs (frame R9 with option +C129)	101
Layout of the input and motor cable connection terminals (frames R10 and R11)	102
Layout of the input and motor cable connection terminals (frames R10 and R11 with option +C129)	102
Lead-through of external resistor and DC cables	103
Connection procedure (IEC)	103
Connection procedure (US)	106
Grounding the motor cable shield at the motor end	107
DC connection (option +H356)	107
Connecting the control cables	107
Control cable connection procedure	107
Grounding the outer shields of the control cables at the cabinet lead-through	108
Routing the control cables inside the cabinet (frames R6 to R8)	110
Routing the control cables inside the cabinet (frame R9)	111
Routing the control cables inside the cabinet (frames R10 and R11)	112
Connecting the control unit cables	112
Connecting the external 230 V or 115 V uninterruptible control voltage (UPS, option +G307)	114
Connecting the emergency stop push buttons (options +Q951, +Q952, +Q963, +Q964)	114
Wiring the starter for auxiliary motor fan (options +M600...+M605)	114
Wiring the thermistor relay(s) (options +L505 and +2L505)	115



Wiring the Pt100 relays (options +2L506, +3L506, +5L506 and +8L506)	116
Connecting the external power supply cables for the cabinet heater and lighting and motor heater (options +G300, +G301 and +G313)	117
Wiring ground fault monitoring for IT ungrounded systems (option +Q954)	118
Setting the voltage range of the auxiliary control voltage transformer (T21)	118
Connecting a PC	119
Installing option modules	120
Mechanical installation of I/O extension, fieldbus adapter and pulse encoder interface modules	120
Wiring I/O extension, fieldbus adapter and pulse encoder interface modules	120
Installation of safety functions modules (frames R6 to R9)	121
installation of safety functions modules (frames R10 and R11)	122
Case 1: FSO-xx safety functions module on Slot 2	122
Case 2: FSO-xx safety functions module above the control unit	124

7. Control unit of frames R6 to R9

Contents of this chapter	125
Layout	126
Default I/O connection diagram of frames R6 to R9	127
Notes:	128
Jumpers and switches	128
External power supply for the control unit	128
AI1 and AI2 as Pt100, Pt1000, PTC and KTY84 sensor inputs (XAI, XAO)	129
DI6 (XDI:6) as PTC sensor input	130
DIIL input (XD24:1)	130
Drive-to-drive link (XD2D)	130
Safe torque off (XSTO)	131
Safety functions module connection (X12)	131
Technical data	131

8. Control unit of frames R10 and R11

Contents of this chapter	135
Layout	136
Default I/O connection diagram of frames R10 and R11	137
Notes:	138
Drive-to-drive link (XD2D)	138
Ground isolation diagram	140

9. Installation checklist

Contents of this chapter	141
Warnings	141
Checklist	141

10. Start-up

Contents of this chapter	143
Start-up procedure	143
Checks/Settings with no voltage connected	143
Powering up the drive	144
Setting up the drive parameters, and performing the first start	144
On-load checks	144



11. Fault tracing

Contents of this chapter	147
LEDs	147
Warning and fault messages	147

12. Maintenance

Contents of this chapter	149
Maintenance intervals	149
Descriptions of symbols	149
Recommended annual maintenance actions by the user	149
Recommended maintenance intervals after start-up	150
Cleaning the interior of the cabinet	151
Cleaning the air inlet (door) meshes (IP22 / UL Type 1, IP42 / UL Type 1 Filtered) ..	151
Replacing the air filters (IP54 / UL Type 12)	152
Inlet (door) filters (IP54 / UL Type 12)	152
Outlet (roof) filters (IP54 / UL Type 12)	152
Heatsink	153
Fans	153
Replacing the cabinet "door" fans	154
Replacing the cabinet fans (frames R6 to R9)	155
Replacing the drive module main fans (frames R6 to R8)	156
Replacing the auxiliary cooling fan of the drive module (frames R6 to R9)	157
Replacing the drive module main fans (frame R9)	158
Replacing the drive module main fans (frames R10 and R11)	159
Replacing the circuit board compartment cooling fan (frames R10 and R11)	160
Replacing the IP54 (UL type 12) roof fan of frames R6 to R8	161
Replacing the IP54 (UL type 12) roof fan of frame R9	162
Replacing the IP54 (UL type 12) roof fan of frames R10 and R11	163
Replacing the drive module (frames R6 to R8)	164
Replacing the drive module (frame R9)	169
Replacing the drive module (frames R10 and R11)	174
Capacitors	180
Reforming the capacitors	180
Replacing the control panel battery	181
Replacing the control unit battery	181
Memory unit	181
Transferring the memory unit	182

13. Technical data

Contents of this chapter	183
Ratings	183
Definitions	185
Derating	186
Ambient temperature derating	186
Altitude derating	187
Deratings for special settings in the drive control program	187
Ex motor, sine filter, low noise	187
High speed mode	190
Fuses (UL)	193
Dimensions and weights	194
Dimensions and weights of sine filter cabinet (option +E206)	195



Free space requirements	195
Losses, cooling data and noise	196
Cooling data and noise for drives with sine filter (option +E206)	197
Terminal and lead-through data for the power cables	198
IEC	198
US	199
Terminal data for the control cables	205
Electrical power network specification	206
Motor connection data	206
Control unit connection data	206
Efficiency	207
Protection classes	207
Ambient conditions	207
Auxiliary circuit power consumption	207
Materials	208
CE marking	209
Compliance with the European Low Voltage Directive	209
Compliance with the European EMC Directive	209
Compliance with the European Machinery Directive	209
Applicable standards	209
Declaration of Conformity (Safe torque off)	210
Compliance with the EN 61800-3:2004	212
Definitions	212
Category C2	212
Category C3	213
Category C4	213
UL marking	213
UL checklist	214
CSA marking	214
“C-tick” marking	214
EAC marking	214
Cyber security disclaimer	215
Disclaimer	215

14. Dimension drawings

Frames R6 to R8 (IP22, IP42 [+B054], UL Type 1) – standard and options +C129, +H350, +H352	218
Frames R6 to R8 (IP54 / UL Type 12 [+B055]) – standard and options +C129, +H350, +H352	219
Frames R10 and R11 (options +C129+F277+F289)	227

15. Safe torque off function

Contents of this chapter	229
Description	229
Compliance with the European Machinery Directive	230
Wiring	230
Activation switch	230
Cable types and lengths	230
Grounding of protective shields	231
Single drive (internal power supply)	231
Multiple drives (internal power supply)	232
Multiple drives (external power supply)	233



Operation principle	234
Start-up including acceptance test	234
Competence	234
Acceptance test reports	234
Acceptance test procedure	234
Use	235
Maintenance	236
Competence	236
Fault tracing	236
Safety data (SIL, PL)	237
Abbreviations	238

16. Resistor braking

Contents of this chapter	239
Operation principle and hardware description	239
Planning the braking system	239
Selecting the brake circuit components	239
Selecting a custom resistor	240
Selecting and routing the external brake resistor cables	240
Minimizing electromagnetic interference	240
Maximum cable length	241
EMC compliance of the complete installation	241
Placing the brake resistors	241
Protecting the system against thermal overload	241
Protecting the resistor cable against short-circuits	241
Mechanical installation of external brake resistors	242
Electrical installation	242
Checking the insulation of the assembly	242
Connection diagram	242
Connection procedure	242
Start-up	242
Technical data	243
Ratings	243
Degree of protection of SAFUR resistors	244
Terminals and cable lead-through data	244

Further information

Product and service inquiries	245
Product training	245
Providing feedback on ABB Drives manuals	245
Document library on the Internet	245



1

Safety instructions



Contents of this chapter

This chapter contains the safety instructions which you must obey when you install and operate the drive and do maintenance on the drive. If you ignore the safety instructions, injury, death or damage can occur.

Use of warnings

Warnings tell you about conditions which can cause injury or death, or damage to the equipment. They also tell you how to prevent the danger. The manual uses these warning symbols:



Electricity warning tells about hazards from electricity which can cause injury or death, or damage to the equipment.



General warning tells about conditions, other than those caused by electricity, which can cause injury or death, or damage to the equipment.



Electrostatic sensitive devices warning tells you about the risk of electrostatic discharge which can cause damage to the equipment.

General safety in installation, start-up and maintenance

These instructions are for all personnel that install the drive and do maintenance work on it.



WARNING! Obey these instructions. If you ignore them, injury or death, or damage to the equipment can occur.

- Secure the cabinet to the floor (see chapter [Mechanical installation](#)) to prevent it from toppling over when you pull out the module. The drive module is heavy and has a high center of gravity.
- Wear protective gloves and long sleeves. Some parts have sharp edges.
- Handle the drive module carefully:
 - Use safety shoes with a metal toe cap to avoid foot injury.
- For frames R10 and R11:
 - Lift the module with a lifting device only. Use the designated lifting points.

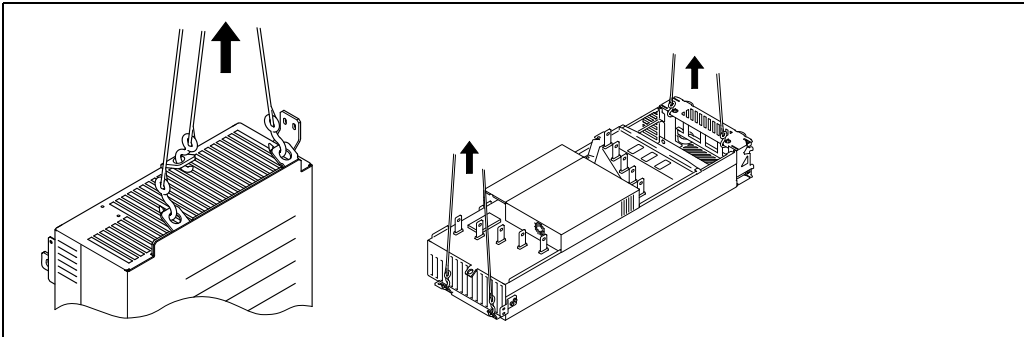

- Make sure that the module does not topple over when you move it on the floor: Extend the support legs by pressing each leg a little down (1, 2) and turning it aside. Whenever possible secure the module also with chains.
- Do not tilt the drive module (A). It is **heavy** and its **center of gravity is high**. The module overturns from a sideways tilt of 5 degrees. Do not leave the module unattended on a sloping floor.

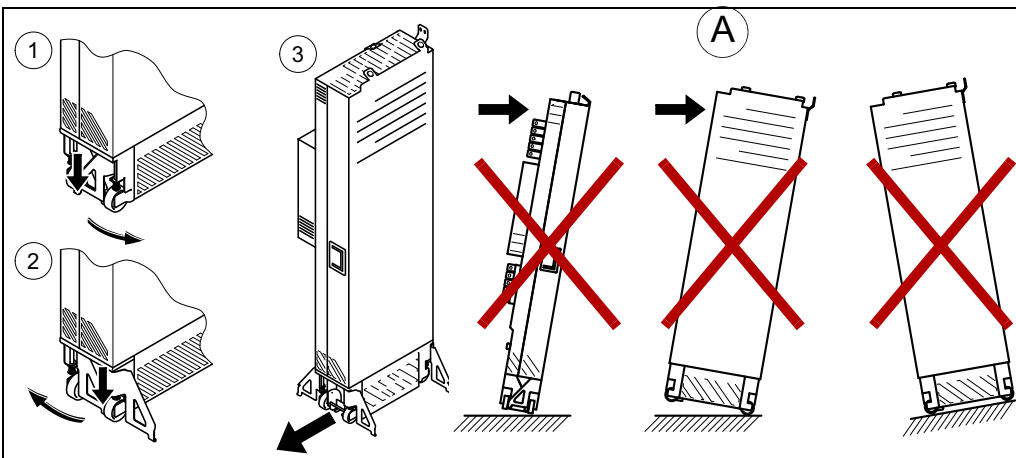

- Do not use the module installation ramp with plinth heights which exceed the maximum height (50 mm [1.97 in]) marked on the ramp.
- Secure the module installation ramp carefully.
- To prevent the drive module from falling, attach its top lifting lugs with chains to the cabinet lifting lug before you push the module into the cabinet and pull it from the cabinet. Work carefully preferably with help from another person as shown below. Keep a constant pressure with one foot on the base of the module to prevent the module from falling on its back.

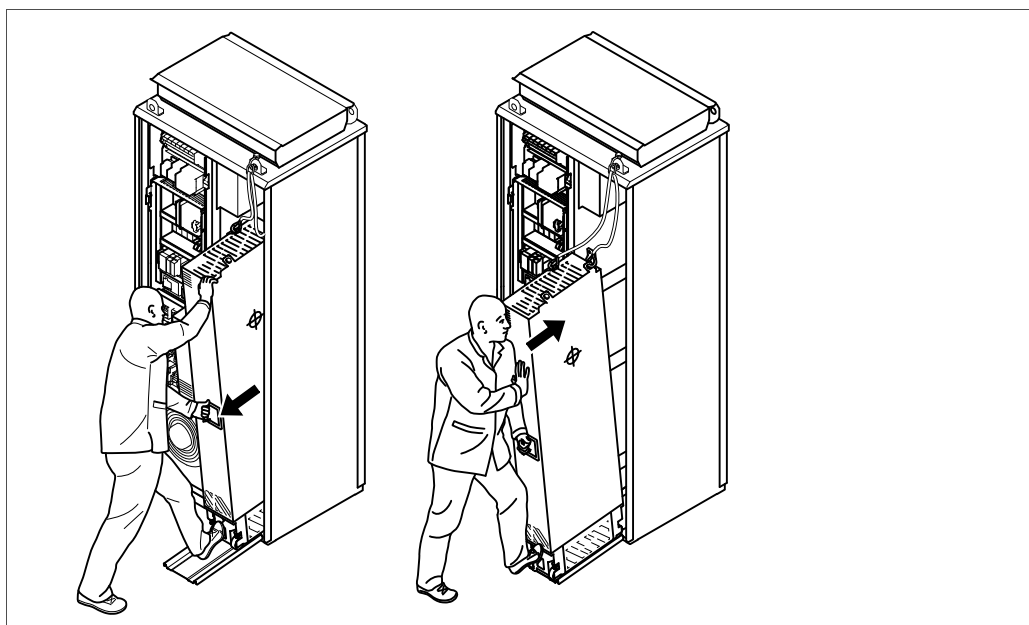

- Beware of hot surfaces. Some parts, such as heatsinks of power semiconductors, remain hot for a while after disconnection of the electrical supply.
- Keep the drive in its package or protect it otherwise from dust and burr from drilling and grinding until you install it. Protect also the installed drive against dust and burr. Electrically conductive debris inside the drive can cause damage or malfunction.
- Vacuum clean the area below the drive before the start-up to prevent the drive cooling fan from drawing the dust inside the drive.
- Make sure that there is sufficient cooling. See section [Examining the installation site](#) on page 55.
- Before you connect voltage to the drive, make sure that the cabinet doors are closed. Keep the doors closed during the operation.
- Before you adjust the drive operation limits, make sure that the motor and all driven equipment can operate throughout the set operation limits.
- Before you activate the automatic fault reset or automatic restart functions of the drive control program, make sure that no dangerous situations can occur. These functions reset the drive automatically and continue operation after a fault or supply break.
- The maximum number of drive power-ups is five in ten minutes. Too frequent power-ups can damage the charging circuit of the DC capacitors.
- Make sure that any safety circuits (for example, emergency stop and Safe torque off) are validated in start-up. For the Safe torque off, see chapter [Safe torque off function](#) on page 229. For other safety functions, see their separate instructions.

Note:

- If you select an external source for start command and it is on, the drive will start immediately after fault reset unless you configure the drive for pulse start. See the firmware manual.
 - When the control location is not set to Local, the stop key on the control panel will not stop the drive.
 - Only authorized persons are allowed to repair a malfunctioning drive.
-

Electrical safety in installation, start-up and maintenance

■ Precautions before electrical work

These warnings are for all personnel who do work on the drive, motor cable or motor.



WARNING! Obey these instructions. If you ignore them, injury or death, or damage to the equipment can occur. If you are not a qualified electrician, do not do installation or maintenance work. Go through these steps before you begin any installation or maintenance work.

- 
1. Clearly identify the work location.
 2. Disconnect all possible voltage sources.
 - Open the main switch-disconnector (Q1) of the drive.
 - Open the disconnector of the supply transformer as the main switch-disconnector (Q1) of the drive does not remove the voltage from the input busbars of the drive.
 - Make sure that reconnection is not possible. Lock the disconnectors to open position and attach a warning notice to them.
 - Disconnect any external power sources from the control circuits before you do work on the control cables.
 - After you disconnect the drive, always wait 5 minutes to let the intermediate circuit capacitors discharge before you continue.
 3. Protect any other energized parts in the work location against contact.
 4. Take special precautions when close to bare conductors.
 5. Measure that the installation is de-energized.
 - Use a multimeter with an impedance of at least 1 Mohm.
 - Make sure that the voltage between the drive input power terminals (L1, L2, L3) and the grounding (PE) busbar is close to 0 V.
 - Make sure that the voltage between the drive module UDC+ and UDC- terminals and the grounding (PE) busbar is close to 0 V.
 6. Install temporary grounding as required by the local regulations.
 7. Ask for a permit to work from the person in control of the electrical installation work.
-

■ Additional instructions and notes



WARNING! Obey these instructions. If you ignore them, injury or death, or damage to the equipment can occur.

- If you are not a qualified electrician, do not do installation or maintenance work.
- Do not install a drive with EMC filter option +E200 or +E202 on an ungrounded power system or a high resistance-grounded (over 30 ohms) power system.
- Do not connect the drive to a voltage higher than what is on the type designation label. If you do, the brake chopper starts to operate which causes the overheating of the brake resistor (if present). Overvoltage can also cause the motor to rush to its maximum speed.
- We do not recommend that you secure the cabinet by arc welding. If you have to, obey the instructions in section [Arc welding](#) on page 69.
- Do not do insulation or voltage withstand tests on the drive or drive modules.

Note:

- The motor cable terminals of the drive are at a dangerous voltage when the input power is on, regardless of whether the motor is running or not.
- The DC bus and brake resistor terminals (UDC+, UDC-, R+ and R-) are at a dangerous voltage.
- External wiring can supply dangerous voltages to the terminals of relay outputs (XRO1, XRO2 and XRO3).
- The Safe torque off function does not remove the voltage from the main and auxiliary circuits. The function is not effective against deliberate sabotage or misuse.



WARNING! Use a grounding wrist band when you handle the printed circuit boards. Do not touch the boards unnecessarily. The boards contain components sensitive to electrostatic discharge.



WARNING! Obey these instructions. If you ignore them, equipment malfunction and damage to the fiber optic cables can occur.

- Handle the fiber optic cables with care.
 - When you unplug the cables, always hold the connector, not the cable itself.
 - Do not touch the ends of the fibers with bare hands as the ends are extremely sensitive to dirt.
 - Do not bend the fiber optic cables too tightly. The minimum allowed bend radius is 35 mm (1.4 in).
-



■ Grounding

These instructions are for all personnel who are responsible for the grounding of the drive.



WARNING! Obey these instructions. If you ignore them, injury or death and equipment malfunction can occur, and electromagnetic interference can increase.

- If you are not a qualified electrician, do not do grounding work.
- Always ground the drive, the motor and adjoining equipment. This is necessary for the personnel safety. Proper grounding also reduces electromagnetic emission and interference.
- Make sure that the conductivity of the grounding conductors is sufficient. See section [Selecting the power cables](#) on page 78. Obey the local regulations.
- Connect the power cable shields to protective earth (PE) of the drive to make sure of personnel safety.
- Make a 360° grounding of the power and control cable shields at the cable entries to suppress electromagnetic disturbances.
- In a multiple-drive installation, connect each drive separately to the protective earth (PE) busbar of the switch board or the transformer.

Note:

- You can use power cable shields as grounding conductors only when their conductivity is sufficient.
 - As the normal touch current of the drive is higher than 3.5 mA AC or 10 mA DC, you must use a fixed protective earth connection. See standard EN 61800-5-1, 4.3.5.5.2.
-



Additional instructions for permanent magnet motor drives

■ Safety in installation, start-up and maintenance

These are additional warnings concerning permanent magnet motor drives. The other safety instructions in this chapter are also valid.



WARNING! Obey these instructions. If you ignore them, injury or death and equipment malfunction can occur.

- Do not do work on the drive when the permanent magnet motor is rotating. A rotating permanent magnet motor energizes the drive including its input power terminals.

Before installation, start-up and maintenance work on the drive:

- Stop the motor.
- Disconnect the motor from the drive with a safety switch or by other means.
- If you cannot disconnect the motor, make sure that the motor cannot rotate during work. Make sure that no other system, like hydraulic crawling drives, can rotate the motor directly or through any mechanical connection like felt, nip, rope, etc.
- Measure that the installation is de-energized.
 - Use a multimeter with an impedance of at least 1 Mohm.
 - Make sure that the voltage between the drive output terminals (U2, V2, W2) and the grounding (PE) busbar is close to 0 V.
 - Make sure that the voltage between the drive input power terminals (L1, L2, L3) and the grounding (PE) busbar is close to 0 V.
 - Make sure that the voltage between the drive module UDC+ and UDC- terminals and the grounding (PE) busbar is close to 0 V.
- Install temporary grounding to the drive output terminals (U2, V2, W2). Connect the output terminals together as well as to the PE.
- Make sure that the operator cannot run the motor over the rated speed. Motor overspeed causes overvoltage can damage or explode the capacitors in the intermediate circuit of the drive.





A large green square with rounded corners, centered on the page, containing the number '2' in a bold, black, sans-serif font.

Introduction to the manual

Contents of this chapter

This chapter describes the manual. It contains a flowchart of steps in checking the delivery, installing and starting up the drive. The flowchart refers to chapters/sections in this manual and to other manuals.

Target audience

This manual is intended for people who plan the installation, install, start up, use and service the drive. Read the manual before you work on the drive. You are expected to know the fundamentals of electricity, wiring, electrical components and electrical schematic symbols.

The manual is written for readers worldwide. Both SI and imperial units are shown.

Contents of the manual

This manual contains the instructions and information for the basic drive configuration. The chapters of the manual are briefly described below.

Safety instructions gives safety instructions for the installation, start-up, operation and maintenance of the drive.

Introduction to the manual gives an introduction to this manual.

Operation principle and hardware description describes the operation principle and constructions of the drive.

Mechanical installation describes how to install the drive mechanically.

Guidelines for planning the electrical installation contains instructions for the motor and cable selection, protections and cable routing.

[Electrical installation](#) gives instructions on wiring the drive.

[Control unit of frames R6 to R9](#) contains the default I/O connection diagram, descriptions of the terminals and technical data for the control unit.

[Control unit of frames R10 and R11](#) contains the default I/O connection diagram and references for the descriptions of the terminals and technical data of the control unit.

[Installation checklist](#) contains a list for checking the mechanical and electrical installation of the drive.

[Start-up](#) describes the start-up procedure of the drive.

[Fault tracing](#) describes the fault tracing possibilities of the drive.

[Maintenance](#) contains preventive maintenance instructions.

[Technical data](#) contains the technical specifications of the drive, eg, the ratings, sizes and technical requirements, provisions for fulfilling the requirements for CE and other markings.

[Dimension drawings](#) contains example dimension drawings of the drive.

[Safe torque off function](#) describes the Safe torque off function of the drive and gives instructions on its implementing.

[Resistor braking](#) describes selection, protection and wiring of optional brake choppers and resistors. The chapter also contains technical data.

Related manuals

See [List of related manuals](#) on the inside of the front cover.

Categorization by frame size and option code

Some instructions, technical data and dimension drawings which concern only certain frame sizes are marked with the symbol of the frame size (R6, R7, R8, R9, R10 or R11) The frame size is marked on the type designation label, see page [49](#).

The instructions, technical data and dimension drawings which concern only certain optional selections are marked with option codes (such as +E205). The options included in the drive can be identified from the option codes visible on the type designation label. The option selections are listed in section [Type designation key](#) on page [49](#).

Quick installation, start-up and operating flowchart

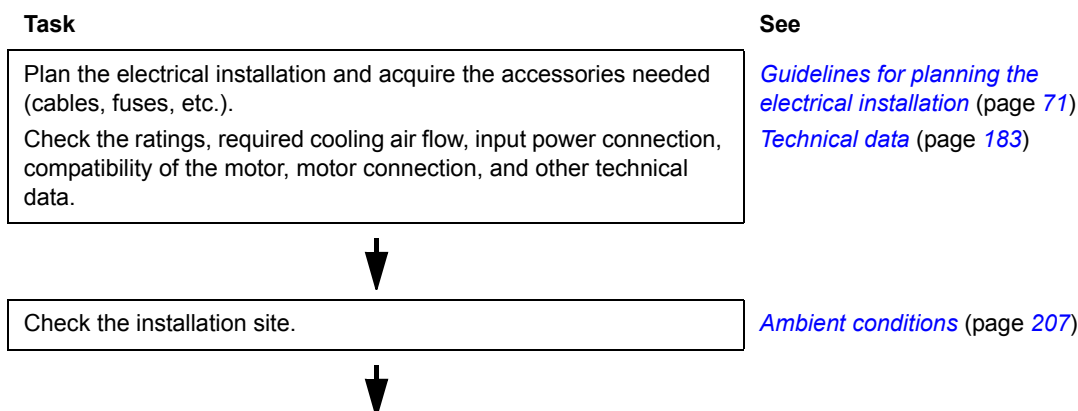

Task	See
Unpack and check the units (only intact units may be started up). Examine that all necessary option modules and equipment are present and correct. Mount the drive.	Mechanical installation (page 55) If the drive has been non-operational for more than one year, the converter DC link capacitors need to be reformed (page 180)
↓	
Route the cables.	Routing the cables (page 83)
↓	
Check the insulation of the supply cable, the motor and the motor cable.	Checking the insulation of the assembly (page 93)
↓	
If the drive is about to be connected to an IT (ungrounded) system, check that the drive is not equipped with EMC filter +E200 or +E202.	Checking the compatibility with IT (ungrounded) systems (page 94)
↓	
Connect the power cables. Connect the control cables.	Connecting the power cables (page 96), Connecting the control cables (page 107),
↓	
Check the installation.	Installation checklist (page 141)
↓	
Start the drive up.	Start-up (page 143)
↓	
Operate the drive: start, stop, speed control etc.	ACS880 quick start-up guide, firmware manual

Terms and abbreviations

Term/ Abbreviation	Explanation
EMC	Electromagnetic compatibility
EMI	Electromagnetic interference
EMT	Electrical metallic tubing
FIO-01	Optional digital I/O extension module
FIO-11	Optional analog I/O extension module
FCAN-01	Optional FCAN-01 CANopen adapter module
FCNA-01	Optional ControlNet™ adapter module
FDCO-01	Optional DDCS communication module with two pairs of 10 Mbit/s DDCS channels
FDNA-01	Optional DeviceNet™ adapter module
FECA-01	Optional EtherCAT adapter module

Term/ Abbreviation	Explanation
FEPL-01	Optional Ethernet POWERLINK adapter module
FENA-11	Optional Ethernet adapter module for EtherNet/IP™, Modbus TCP and PROFINET IO protocols
FENA-21	Optional Ethernet adapter module for EtherNet/IP™, Modbus TCP and PROFINET IO protocols, 2-port
FLON-01	Optional LonWorks® adapter module
FPBA-01	Optional PROFIBUS DP adapter module
FEN-01	Optional TTL incremental encoder interface module
FEN-11	Optional TTL absolute encoder interface module
FEN-21	Optional resolver interface module
FEN-31	Optional HTL incremental encoder interface module
FSO-12, FSO-21	Optional functional safety module
Frame (size)	Physical size of the drive
IGBT	Insulated gate bipolar transistor; a voltage-controlled semiconductor type widely used in drives due to their easy controllability and high switching frequency.
I/O	Input/Output
MCCB	Molded case circuit breaker
ZCU	Drive control unit. As standard, the external I/O control signals are connected to the control unit, or optional I/O extensions mounted on it.
ZGAB	Brake chopper adapter board
ZGAD, BGAD	Gate driver adapter board
ZINT	Main circuit board
ZMU	The memory unit attached to the control unit of the drive
RFI	Radio-frequency interference
R6...R11	Frame size designation of the drive
SAR	Safe acceleration range
SBC	Safe brake control
SLS	Safely-limited speed without encoder
SS1	Safe stop 1
SSE	Safe stop emergency
SSM	Safe speed monitor without encoder
STO	Safe torque off



3

Operation principle and hardware description

Contents of this chapter

This chapter briefly describes the operation principle and construction of the drive.

Product overview

The ACS880-07 is an air-cooled cabinet-installed drive for controlling asynchronous AC induction motors, permanent magnet synchronous motors, AC induction servomotors and ABB synchronous reluctance motors (SynRM motors) with option N7502.

■ Single-line circuit diagram of the drive

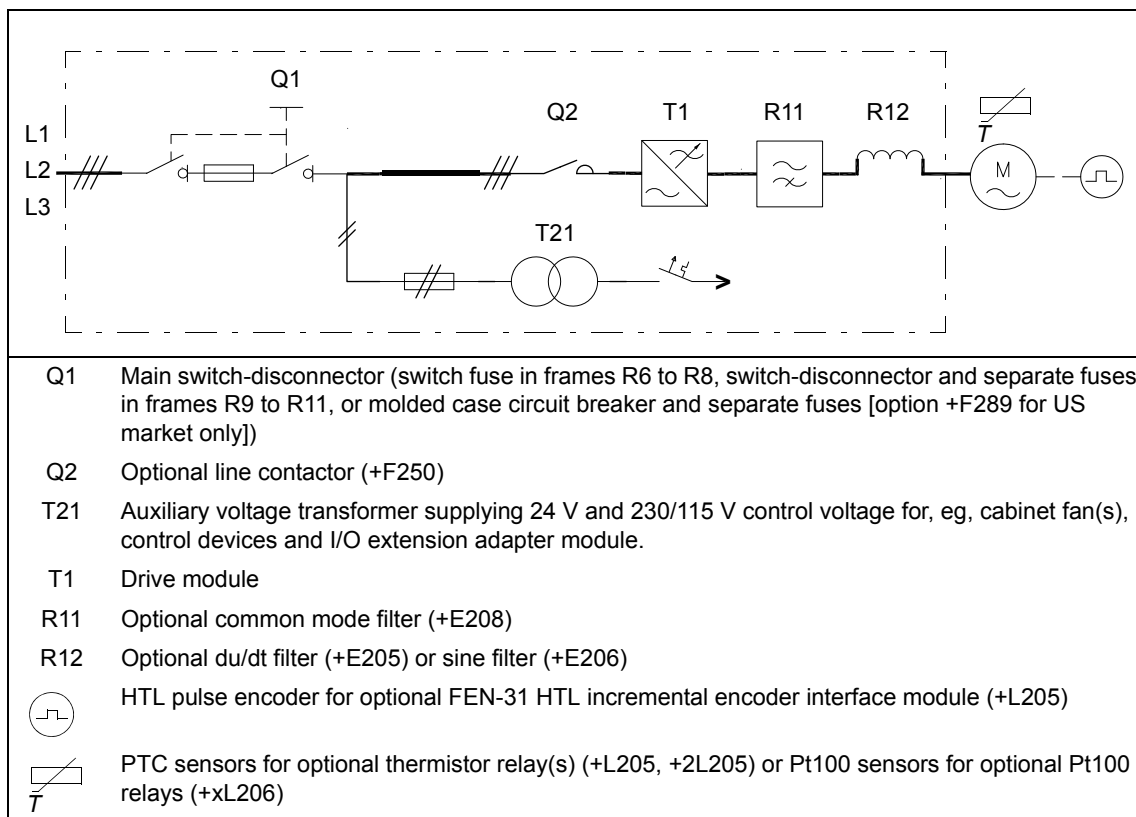

■ **Block diagram of the brake and DC options (+D150, +D151 and +H356)**

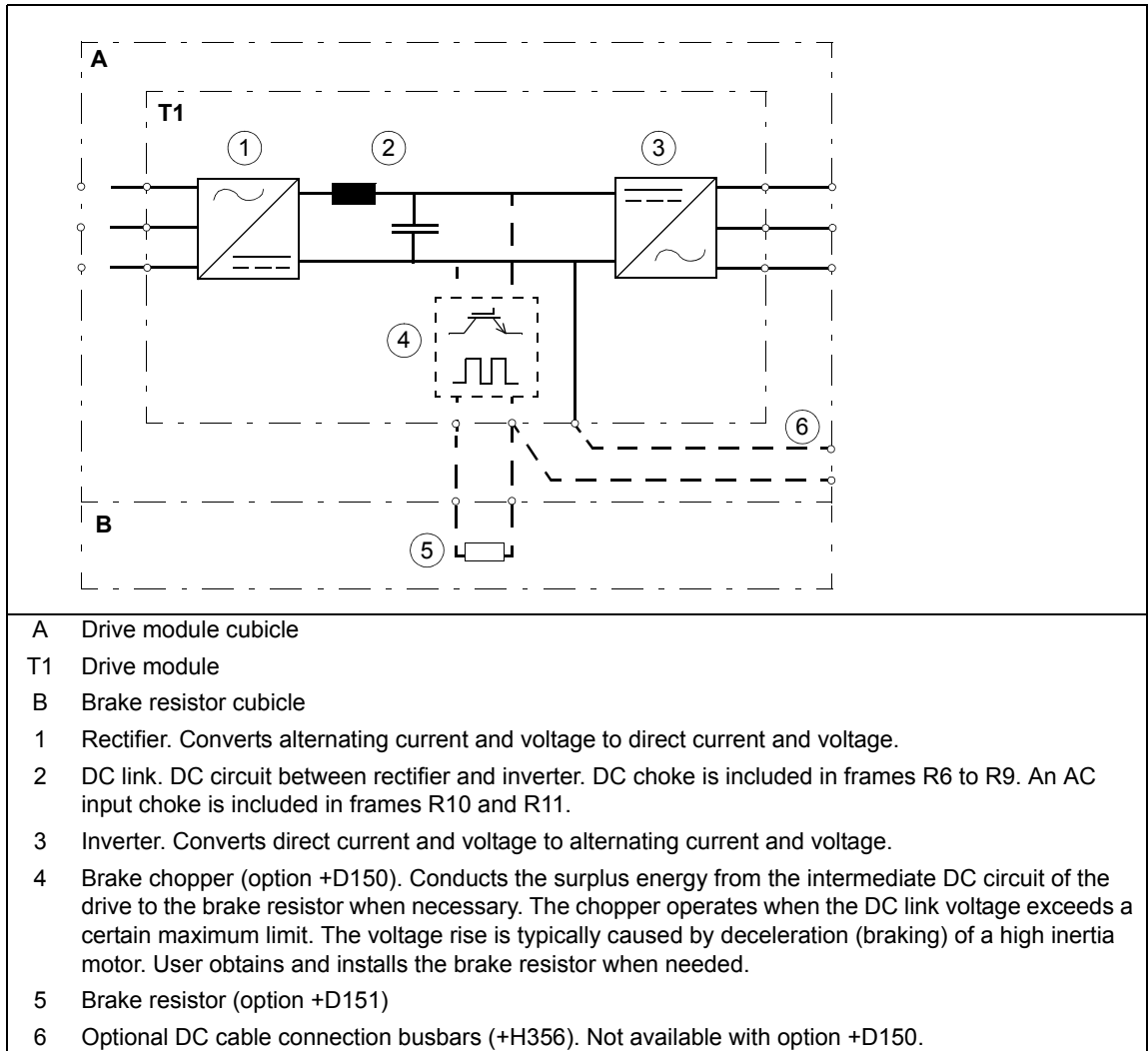

■ General information on the cabinet layout



IP22/IP42
UL Type 1 /
UL Type 1 Filtered

IP54
UL Type 12



UL Type 1 with molded case circuit breaker (option +F289 for US market only)

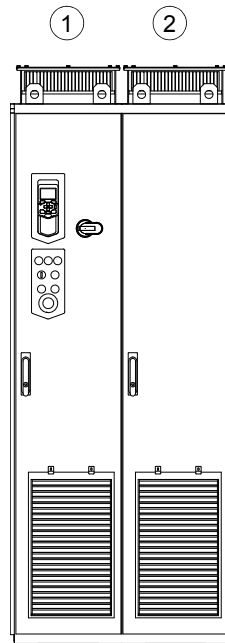

Example cabinet line-up

- | | |
|---|---|
| 1 | Frames R6 to R8: drive module cubicle.
Frames R9 to R11: two cubicles with one door (main switch and power cabling cubicle and drive module cubicle) |
| 2 | Brake resistor cubicle with option +D151 |

■ Cabinet layout of frames R6 to R8

The cabinet layout without shrouds is shown below.

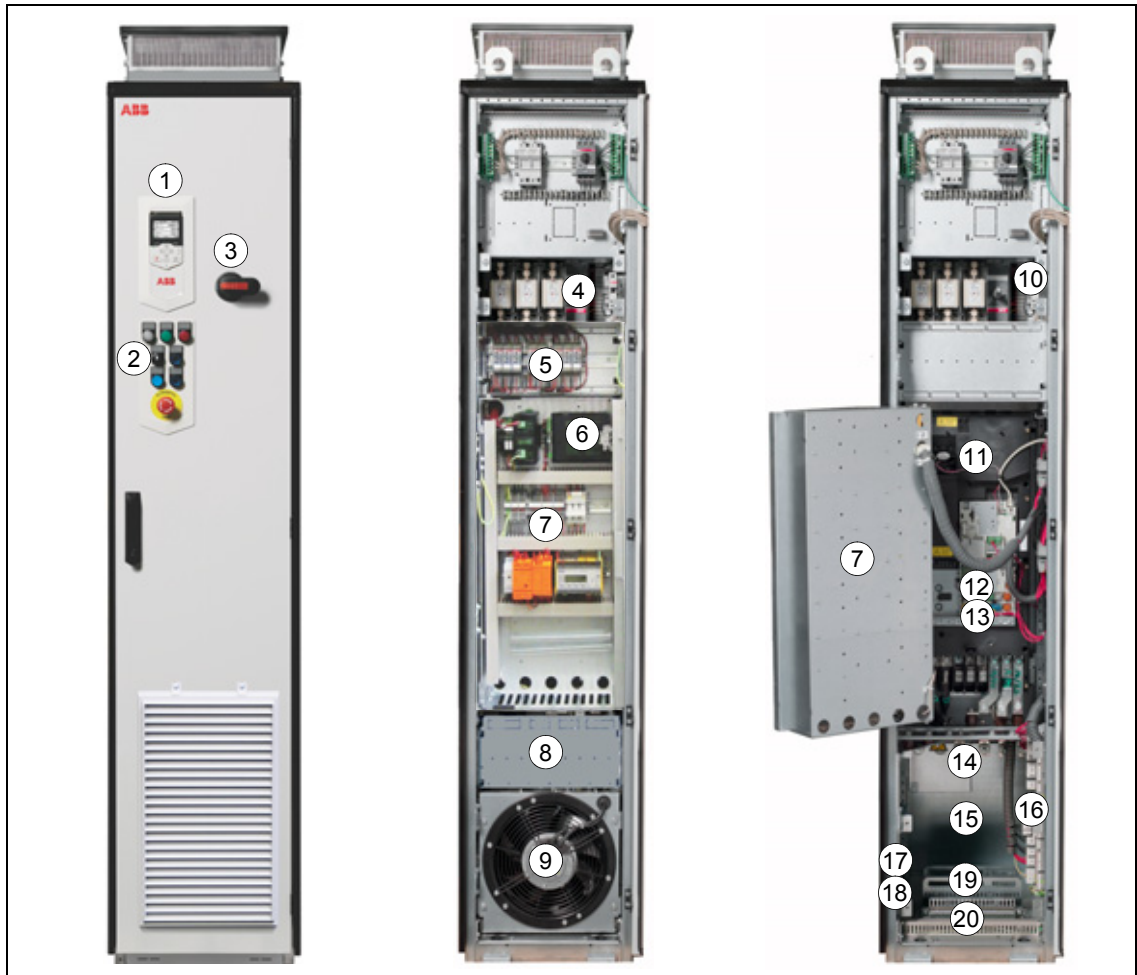

1	Drive control panel	12	Control unit, see page 125 .
2	Door switches and lights, see page 42 .	13	Optional terminal block for external control unit connections (X504, option +L504)
3	Main switch handle	14	Power cable connection terminals and du/dt filter (option +E205) and common mode filter (option +E208) behind
4	Main switch-disconnector with fuses		
5	Thermistor and Pt100 relays (options +L505 and +L506)	15	Common mode filter (option +E208)
6	Buffering module C22	16	Connection terminals for options +F250, +Q951, +Q952, +Q963, +Q964+Q968, +Q954, +M600...+M605,+ L505, +L506. See page 41 .
7	Swing-out frame	17	Cabinet heater (option +G300)
8	Mounting plate with connection terminals for options +G300, +G307, +G313 at the back side of the plate	18	PE busbar
9	"Door" fan	19	Power cable lead-throughs
10	Auxiliary voltage transformer (T21)	20	Control cable lead-through
11	Drive module	-	-

Cabinet layout of frames R6 to R8 with option +C129

The cabinet layout without shrouds is shown below.



1	Drive control panel	11	Buffering module C22
2	Door switches and lights, see page 42.	12	Swing-out frame
3	Main switch handle	13	Mounting plate with connection terminals for options +G300, +G307, +G313 at the back side of the plate
4	Power and control cable lead-throughs	14	"Door" fan
5	Ground bar	15	Drive module
6	Input cable connection terminals	16	Control unit, see page 125.
7	Motor cable connection terminals	17	Optional terminal block for external control unit connections (X504, option +L504)
8	Auxiliary voltage transformer (T21)	16	Connection terminals for options +F250, +Q951, +Q952, +Q963, +Q964+Q968, +Q954, +M600...+M605, +L505, +L506. See page 41.
9	Main switch-disconnector with fuses	19	Cabinet heater (option +G300)
10	Thermistor and Pt100 relays (options +L505 and +L506)	-	-

■ **Cabinet layout of frames R6 to R8 with options +C129 and +F289**

Option +C129 +F289 is available for US market only. The cabinet layout without shrouds is shown below.



1	Drive control panel	9	Auxiliary voltage transformer (T21)
2	Door switches and lights, see page 42.	10	Thermistor and Pt100 relays (options +L505 and +L506)
3	Main switch handle	11	Buffering module C22
4	Input power cable lead-throughs	12	Swing-out frame
5	Ground bar	13	Mounting plate with connection terminals for options +G300, +G307, +G313 at the back side of the plate
6	Input power cable terminals	14	"Door" fan
7	Molded case circuit breaker (option +F289)		
8	Main fuses for control devices, IP54 fan transformer (with option +B055), V-meter (option +G334), starter for auxiliary motor fan (option +M600)		



15	Control cable lead-throughs	20	Control unit, see page 125 .
16	Motor cable lead-throughs	21	Optional terminal block for external control unit connections (X504, option +L504)
17	Ground bar	22	Common mode filter (option +E208)
18	Motor cable connection terminals	23	Connection terminals for options +F250, +Q951, +Q952, +Q963, +Q964+Q968, +Q954, +M600...+M605,+ L505, +L506. See page 41 .
19	Drive module		

■ Cabinet layout of frame R9

The cabinet layout is shown below. See also the next page.

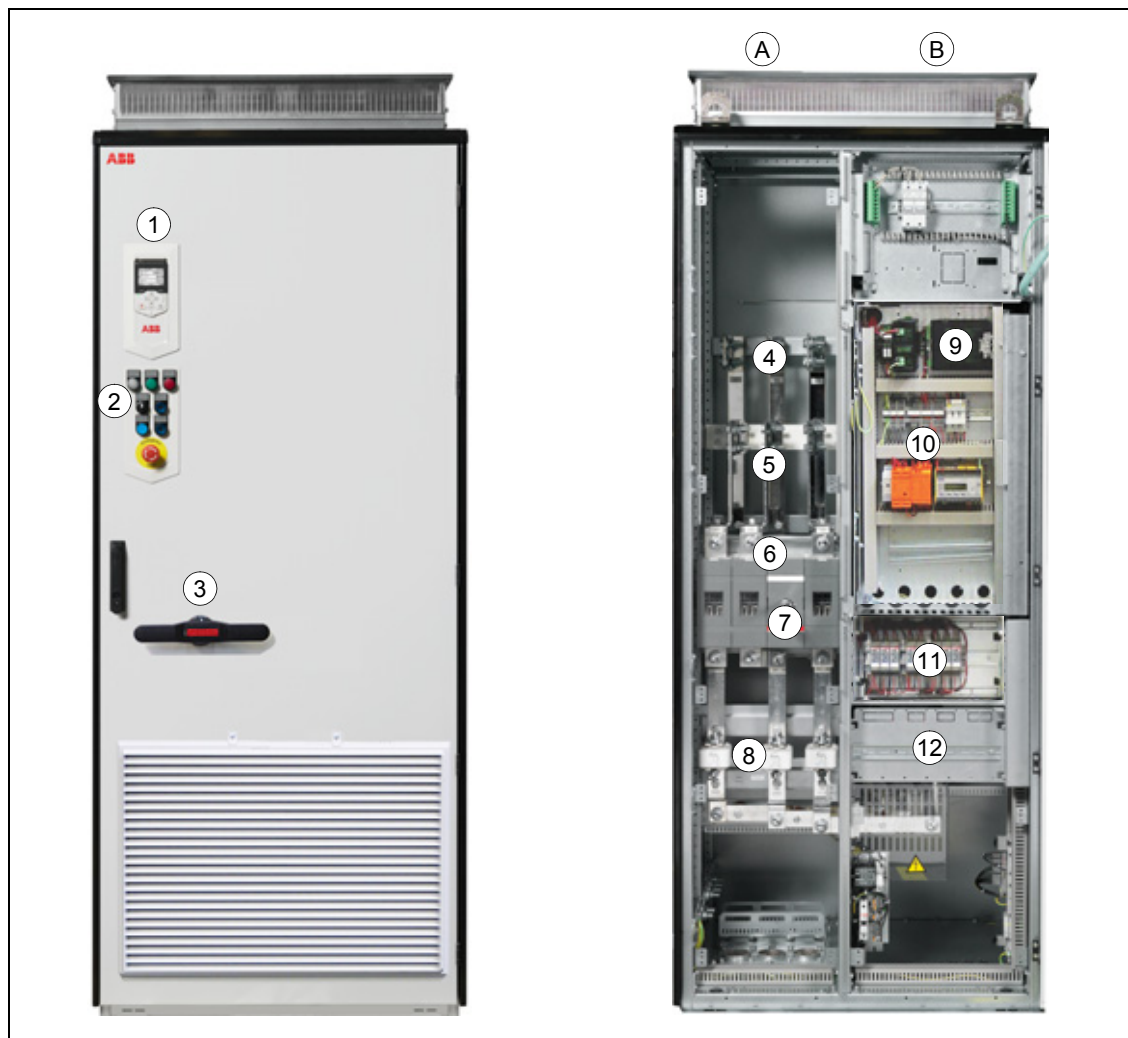

A – Main breaker and power cabling cubicle		B – Drive module cubicle	
1	Drive control panel	9	Buffering module
2	Operating switch	10	Swing-out frame
3	Main switch handle	11	Thermistor and Pt100 relays (options +L505 and +L506)
4	Motor cable connection terminals	12	Mounting plate with connection terminals for options +G300, +G301, +G307, +G313 at the back side of the plate
5	du/dt filter (option +E205)	-	-
6	Input cable connection terminals	-	-
7	Main switch-disconnector or molded case circuit breaker with option +F289	-	-
8	AC fuses	-	-

34 Operation principle and hardware description

The cabinet layout without shrouds, with the swing-out frame open is shown below.

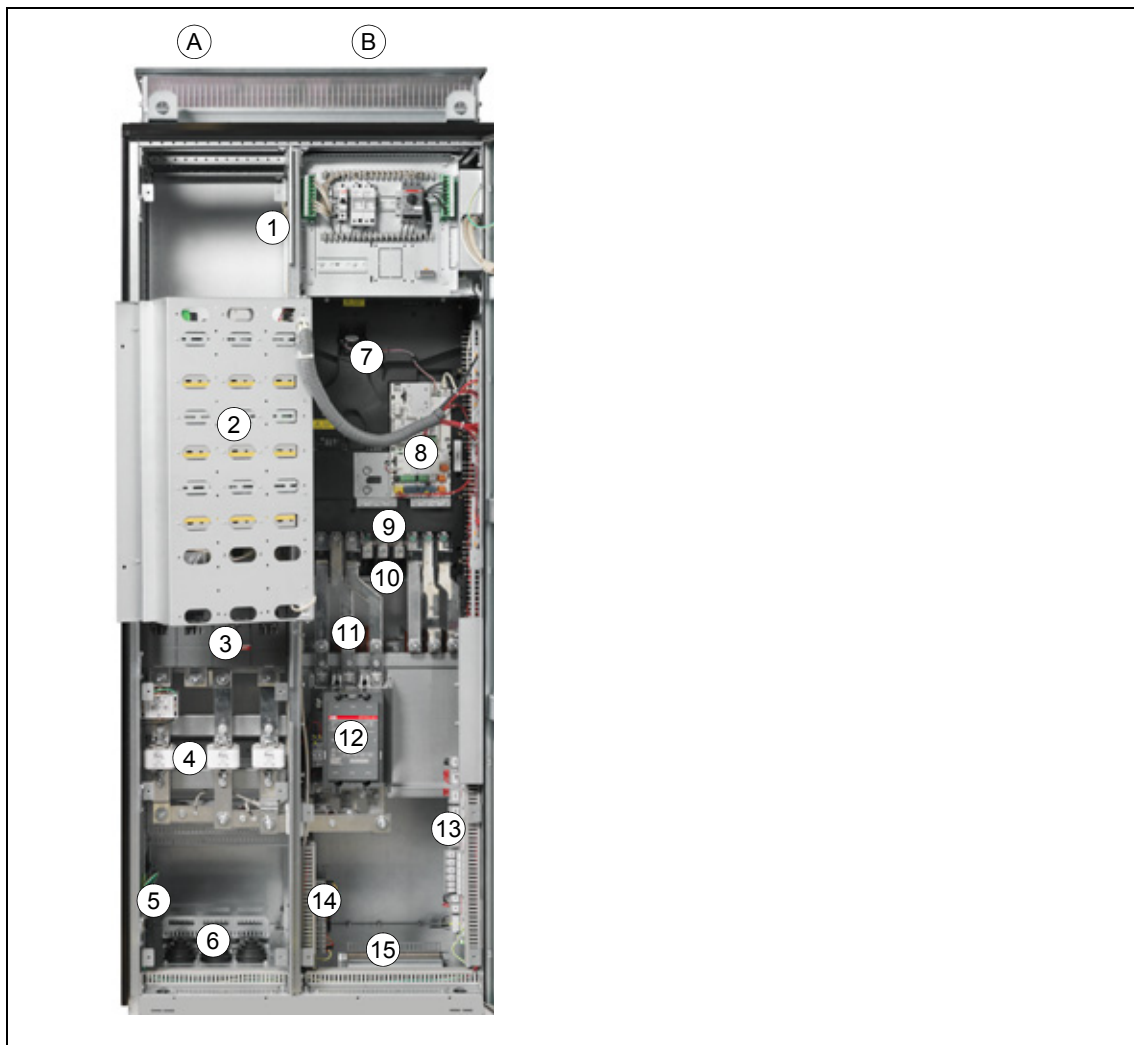

A – Main breaker and power cabling cubicle		B – Drive module cubicle	
1	Auxiliary voltage transformer (T21)	8	Control unit, see page 125 .
2	Swing-out frame	9	Optional terminal block for external control unit connections (X504, option +L504)
3	Main switch-disconnector or molded case circuit breaker with option +F289	10	Connection terminals for external brake resistor and DC cables
4	AC fuses	11	Common mode filter (option +E208) behind the busbars
5	PE-terminal	12	Line contactor (option +F250)
6	Power cable lead-throughs	13	Connection terminals for options +F250, +Q951, +Q952, +Q963, +Q964+Q968, +Q954, +M600...+M605,+ L505, +L506. See page 41 .
7	Drive module	14	Cabinet heater (option +G300)
-	-	15	Control cable lead-through

■ **Cabinet layout of frame R9 with options +C129 and +F289**

The cabinet layout is shown below. See also the next page.



A – Main breaker and power cabling cubicle		B – Drive module cubicle	
1	Drive control panel	10	Buffering module
2	Operating switch	11	Swing-out frame
3	Main switch handle	12	Thermistor and Pt100 relays (options +L505 and +L506)
4	Power cable lead-throughs		
5	Input cable connection terminals	13	Mounting plate with connection terminals for options +G300, +G301, +G307, +G313 at the back side of the plate
6	Motor cable connection terminals	-	-
7	Ground bar	-	-
8	Molded case circuit breaker (option +F289)	-	-
9	AC fuses	-	-

The cabinet layout with the swing-out frame open is shown below.

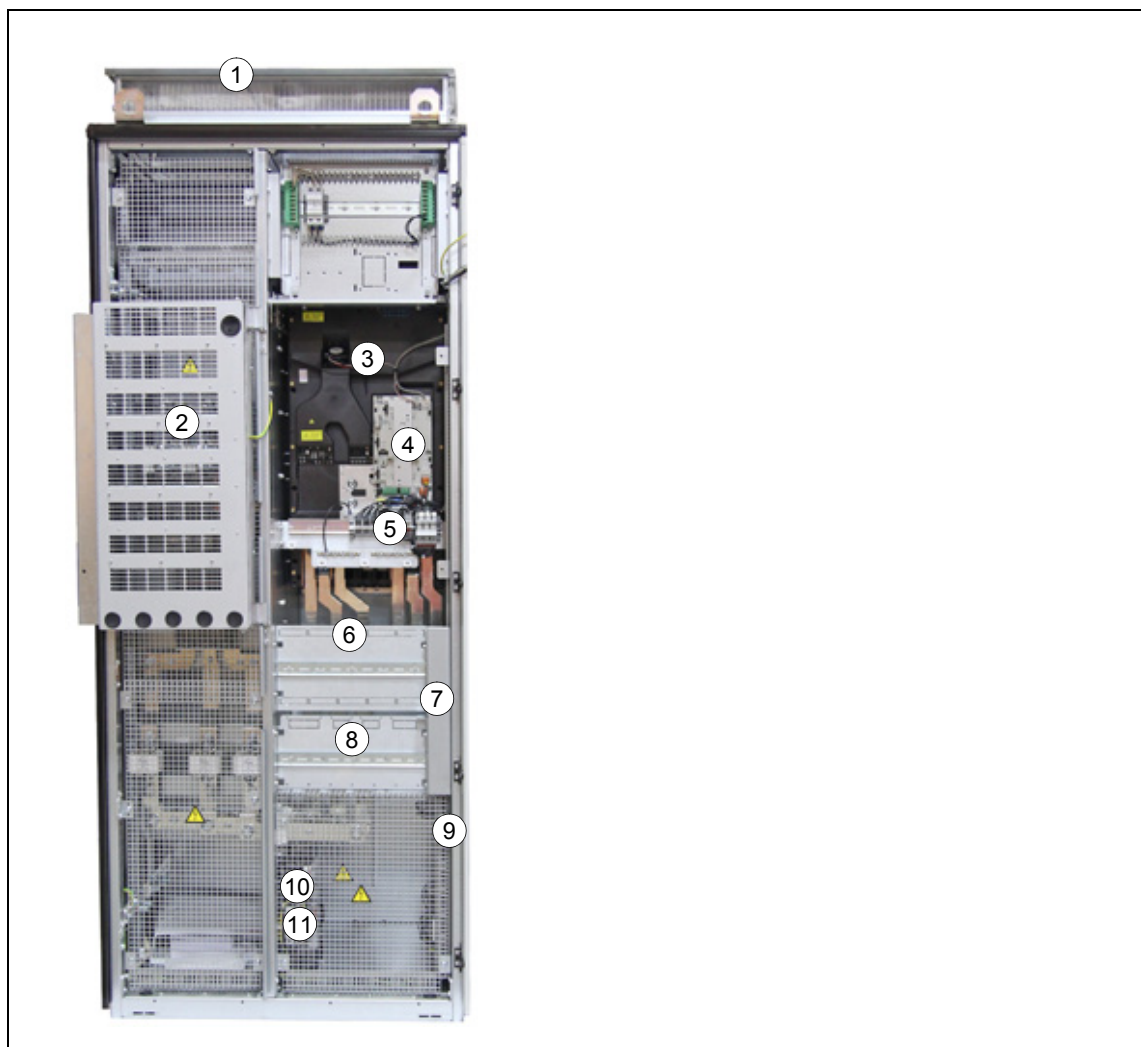

1	Control cable lead-through	7	Connection terminals for external brake resistor and DC cables
2	Swing-out frame	8	Line contactor (option +F250)
3	Drive module	9	Connection terminals for options +F250, +Q951, +Q952, +Q963, +Q964+Q968, +Q954, +M600...+M605,+ L505, +L506. See page 41.
4	Control unit, see page 125.	10	Cabinet heater (option +G300)
5	Optional terminal block for external control unit connections (X504, option +L504)	11	Auxiliary voltage transformer (T21)
6	Common mode filter (option +E208) behind the busbars	-	-

■ **Cabinet layout of frames R10 and R11 – bottom entry and exit of cables**

The cabinet layout is shown below. See also the next page.



A – Main breaker and power cabling cubicle		B – Drive module cubicle	
1	Drive control panel	-	See the next page.
2	Operating switch	-	-
3	Main switch handle	-	-
4	Buffering module	-	-
5	Swing-out frame	-	-
6	Thermistor and Pt100 relays (options +L505 and +L506)	-	-
7	Mounting plate with connection terminals for options +G300, +G301, +G307, +G313 at the back side of the plate	-	-
8	“Door” fan		

The cabinet layout without shrouds, with the swing-out frame open is shown below.

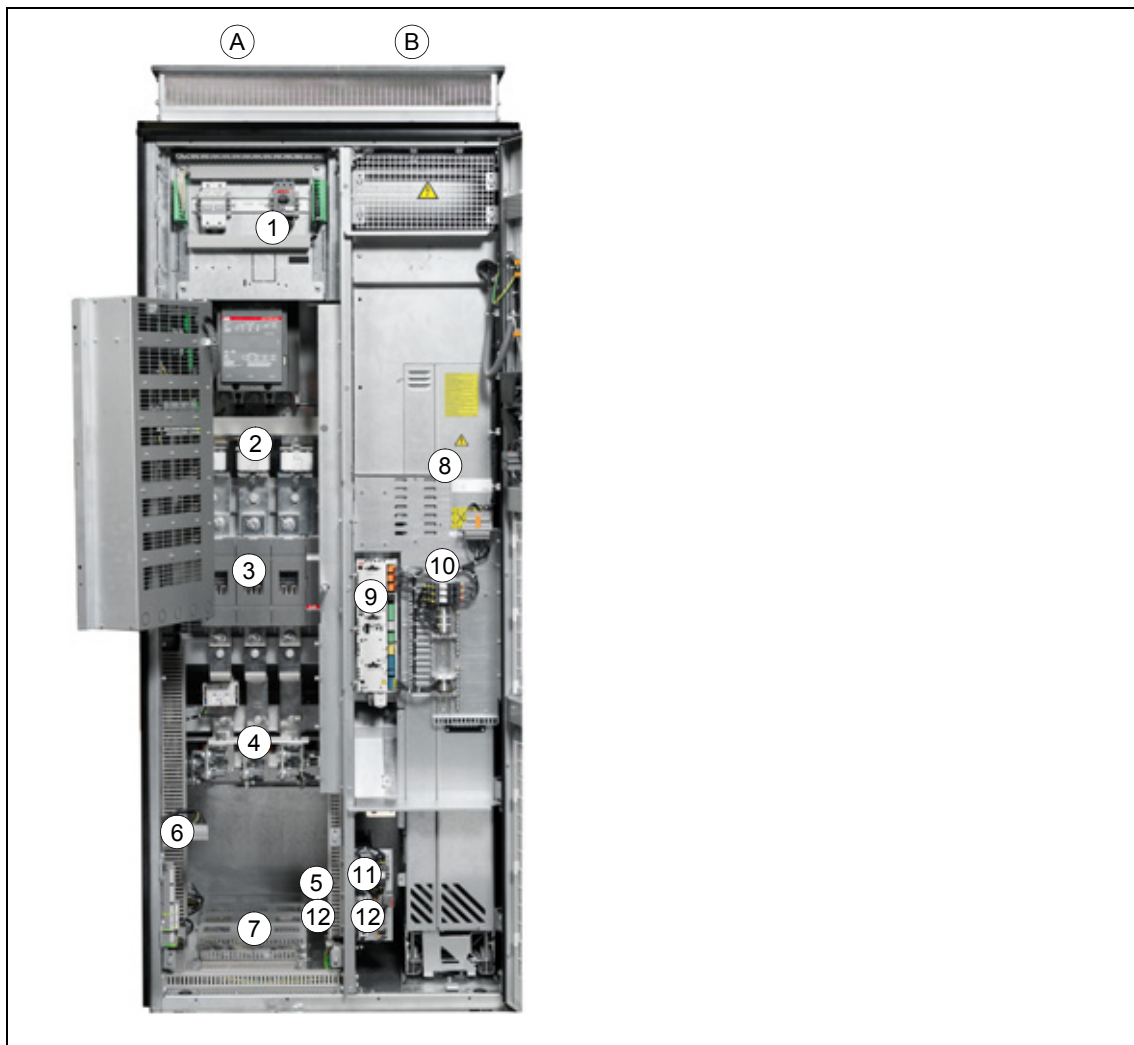

A – Main breaker and power cabling cubicle		B – Drive module cubicle	
1	Main fuses for control devises, IP54 fan transformer (with option +B055), V-meter (option +G334), starter for auxilliary motor fan (option +M600)	8	Drive module
2	AC fuses	9	Control unit, see page 135 .
3	Main switch-disconnector	10	Optional terminal block for external control unit connections (X504, option +L504)
4	Input and motor cable connection terminals	11	Auxiliary voltage transformer (T21)
5	PE-terminal	12	Cabinet heater
6	Connection terminals for options +F250, +Q951, +Q952, +Q963, +Q964+Q968, +Q954, +M600...+M605,+ L505, +L506. See page 41 .	-	-
7	Power and control cable lead-throughs	-	-

■ **Cabinet layout of frames R10 and R11 – top entry and exit of cables (option +C129)**

The cabinet layout is shown below.



A – Main breaker and power cabling cubicle		B – Drive module cubicle	
1	Main fuses for control devices, IP54 fan transformer (with option +B055), V-meter (option +G334), starter for auxiliary motor fan (option +M600)	8	Drive module
2	AC fuses	9	Control unit, see page 135.
3	Main switch-disconnector	10	Optional terminal block for external control unit connections (X504, option +L504)
4	Input and motor cable connection terminals	11	Auxiliary voltage transformer (T21)
5	PE-terminal	12	Cabinet heater
6	Power and control cable lead-throughs	-	-
7	“Door” fan	-	-
	Connection terminals for options +F250, +Q951, +Q952, +Q963, +Q964+Q968, +Q954, +M600...+M605, +L505, +L506. See page 41.		

■ Overview of power and control connections

The diagram shows the power connections and control interfaces of the drive.

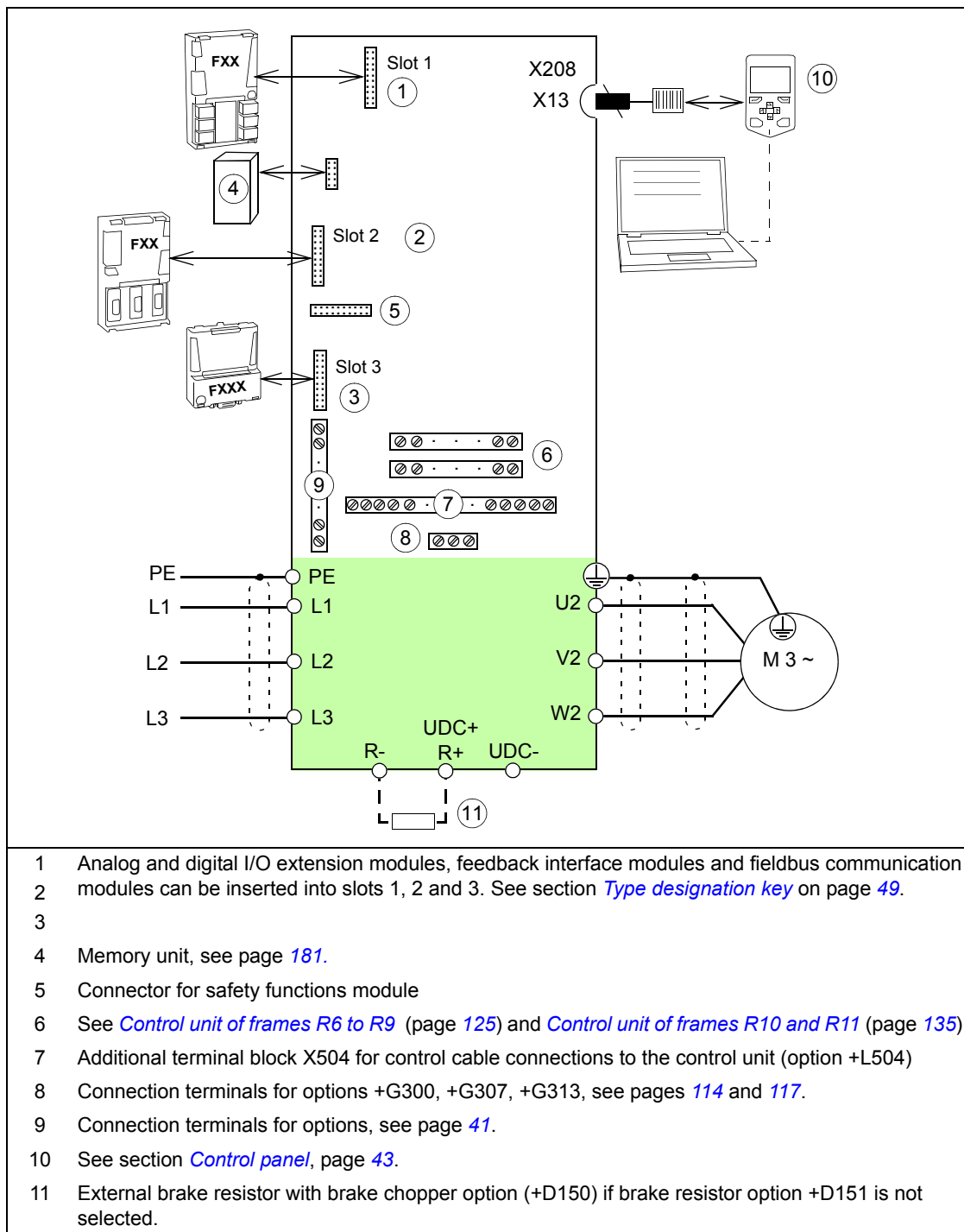

The layout of external control connection terminals at the side of the drive cabinet is shown below. The composition depends on the options selected.

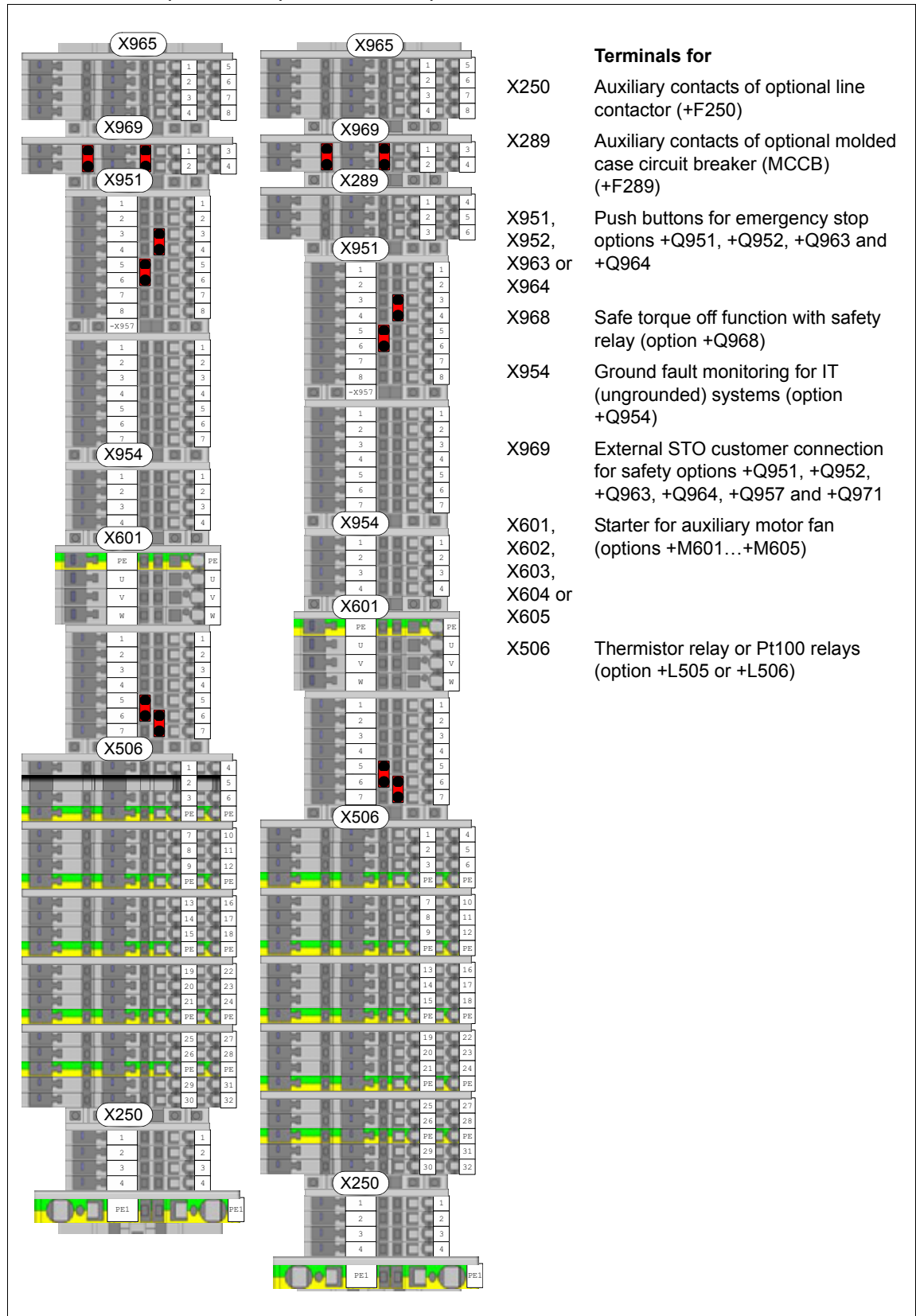

Door switches and lights

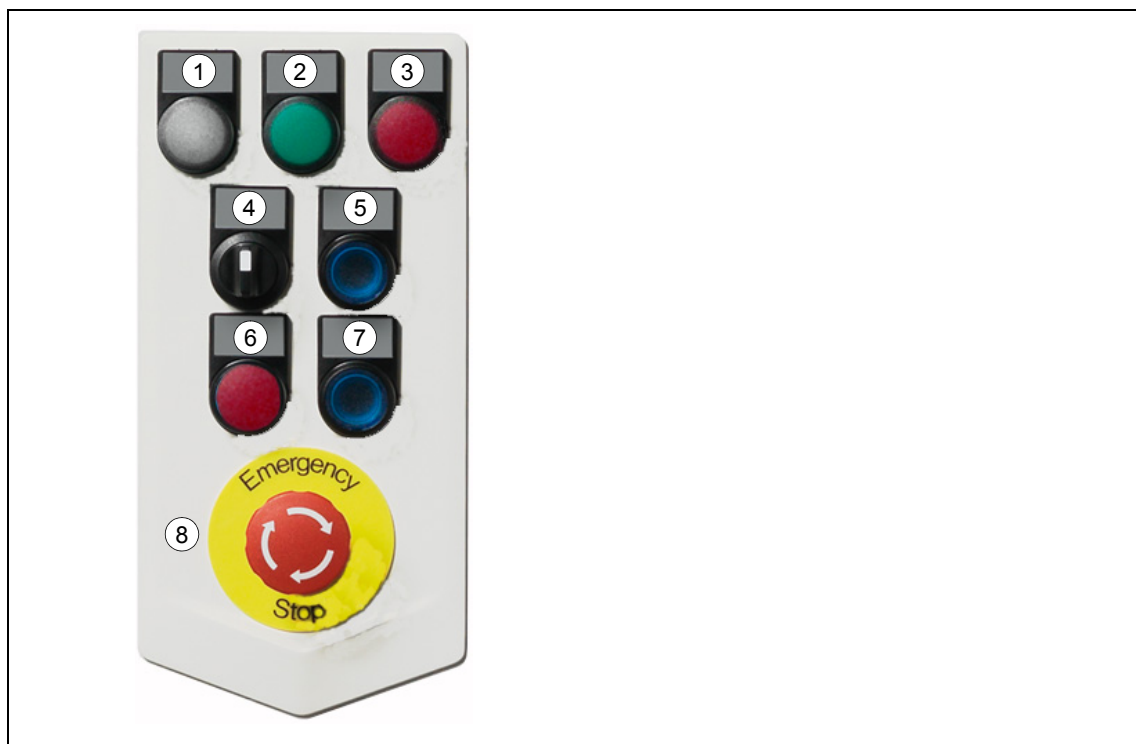

	Label in English	Label in local language	Description
1	READY	-	Ready pilot light (option +G327)
2	RUN	-	Run pilot light (option+G328)
3	FAULT	-	Fault pilot light (option +G329)
4	MAIN CONT. OFF ON 	-	Operating switch with option +F250 0 Opens the main contactor (Q2) and disables starting of the drive 1 Closes the main contactor (Q2)
5	EMERGENCY STOP RESET	-	Emergency stop reset push button with options +Q951,+Q952, +Q963 and +Q964
6	GROUND FAULT RESET	-	Ground fault pilot light with option +Q954
7	-	-	Reserved for application engineered options
8	EMERGENCY STOP	-	Emergency stop push button with options +Q951,+Q952, +Q963 and +Q964

The layout depends on the options selected.

Main switch-disconnector Q1

The switch-disconnector handle switches the main voltage to the drive on and off.

■ Control panel

The ACS-AP-I is the user interface of the drive. It provides the essential controls such as Start/Stop/Direction/Reset/Reference, and the parameter settings for the control program.

One control panel can be used to control several drives through a panel link.

The control panel can be removed by pulling it forward from the top edge and reinstalled in reverse order. For the use of the control panel, see the firmware manual or *ACS-AP assistant control panel user's manual* (3AUA0000085685 [English]).



Control by PC tools

There is a USB connector on the front of the panel that can be used to connect a PC to the drive. When a PC is connected to the control panel, the control panel keypad is disabled.

Descriptions of cabinet options

Note: All options are not available for all drive types, do not coexist with certain other options, or may require additional engineering. Check actual availability with ABB.

■ Degree of protection

Definitions

According to IEC/EN 60529, the degree of protection is indicated by an IP code where the first numeral means protection against ingress of solid foreign objects, and the second numeral protection against ingress of water. The IP codes of the standard cabinet and options covered in this manual are defined below.

IP code	The equipment is protected ...	
	First numeral	Second numeral
IP20	against ingress of solid foreign objects \geq 12.5 mm diameter *	not protected against water
IP22	against ingress of solid foreign objects \geq 12.5 mm diameter *	against dripping (15° tilting) water
IP42	against ingress of solid foreign objects \geq 1 mm	against dripping (15° tilting) water
IP54	dust-protected	against splashing water

* meaning for protection of persons: against access to hazardous parts with finger

IP22 and UL Type 1 (standard)

The degree of protection of the standard drive cabinet is IP22 (UL Type 1). The air outlet at the top of the cabinet is covered with a brass grating. The air inlet gratings are covered

with plastic gratings. With doors open, the degree of protection of the standard cabinet and all cabinet options is IP20. The live parts inside the cabinet are protected against contact with clear plastic shrouds or metallic gratings.

IP42 and UL Type 1 Filtered (option +B054)

This option provides the degree of protection of IP42 (UL type 1 Filtered). The air inlet gratings are covered with a metallic mesh between the inner metallic grating and the outer plastic grating.

IP54 and UL Type 12 (option +B055)

This option provides the degree of protection of IP54 (UL type 12). It equips the cabinet air inlets with filter housings containing folded board air filter mats between the inner metallic grating and the outer plastic grating. An additional fan on the cabinet roof is included.

■ Channeled air inlet through bottom (option +C128)

This option provides air intake to the drive through the cabinet bottom when the drive is installed on an air duct in the floor,

See also

- [Air inlet through the bottom \(option +C128+B055\)](#) on page 67.

Required options: IP54 degree of protection (+B055)

■ Channeled air outlet (option +C130)

This option provides a collar for fitting an air outlet duct. The collar is located on the cabinet roof. The option equips the cabinet air inlets with filter housings containing folded board air filter mats between the inner metallic grating and the outer plastic grating.

See also

- [Air outlet duct on the cabinet roof \(option +C130\)](#) on page 68.

■ Marine construction (option +C121)

The option includes the following accessories and features:

- reinforced mechanics
- grab railings
- door flush bolt which allows the door to open 90 degrees and prevents it from slamming close
- self-extinctive materials
- flat bars at base of the cabinet for fastening
- fastening braces at the top of the cabinet.

Required options: Appropriate additional wire marking option (see page 47) according to the requirements of the classification society

Related options: halogen-free materials and wiring (+G330)

■ UL listed (option +C129)

The option includes factory inspection of the cabinet according to UL 508A and the following accessories and features:

- US type main switch fuse
- top entry and exit of cables
- US cable conduit entry (plain plate without ready-made holes)
- all components UL Listed/Recognized
- maximum supply voltage 600 V.

Related options: +H350 (bottom entry of cables), +H352 (bottom exit of cables) and +H358 (cable conduit entry)

The option is not available with +C121 (marine construction) or +E206 (sine output filter).

■ CSA approved (option +C134)

The option includes the following accessories and features:

- US/CSA type main switch fuse
- bottom entry and exit of cables
- US cable conduit entry (plain plate without ready-made holes)
- all components UL/CSA listed/recognized
- maximum supply voltage 600 V.

■ Plinth height (options +C164 and +C179)

- The standard height of the cabinet plinth is 50 mm. These options specify a plinth height of 100 mm (+C164) or 200 mm (+C179).

■ Seismic design (option +C180)

The option involves seismic capability according to International building code 2012, test procedure ICC-ES AC-156. The installation level must not exceed 25% of the height of the building, and S_{DS} (installation site specific spectral acceleration response) must not exceed 2.0 g.

The option adds the following accessories and features:

- reinforced plinth
- flat bars at base of the cabinet for fastening.

■ Resistor braking (options +D150 and +D151)

See chapter [Resistor braking](#) on page 239.

■ EMC filters (options + E200, +E201, +E202, +E210)

See section [Type designation key](#) on page 49 and sections [Compliance with the European EMC Directive](#) on page 209 and [Compliance with the EN 61800-3:2004](#) on page 212.

More information: *Technical Guide No. 3 – EMC Compliant Installation and Configuration for a Power Drive System* (3AFE61348280 [English])

■ du/dt filter (option +E205)

The du/dt filter protects the motor insulating system by reducing the voltage rise speed at the motor terminals. The filter also protects the motor bearings by reducing the bearing currents.

More information on when the option is required: See section [Examining the compatibility of the motor and drive](#) on page 72.

■ Sine filter (option +E206)

The sine filter protects the motor insulating system. du/dt filter can be replaced with a sine filter.

More information: see page 77.

■ Common mode filter (option +E208)

The common mode filter contains ferrite rings mounted around the drive DC busbars. The filter protects the motor bearings by reducing the bearing currents.

More information on when the option is required: See section [Examining the compatibility of the motor and drive](#) on page 72.

■ Cabinet heater with external supply (option +G300)

The option contains:

- 50 W heating elements in the cubicles where needed
- load switch for providing electrical isolation during service
- miniature circuit breaker for overcurrent protection
- terminal block for external power supply.

The heater prevents humidity condensation inside the cabinet when the drive is not running. The power output of the semiconductor-type heating elements depends on the environmental temperature. The customer must switch the heating off when it is not needed by cutting the supply voltage off.

The customer must supply the heater from an external 110...240 V AC power source.

The option is not available with +C134 (CSA Approved).

See also

- [Connecting the external power supply cables for the cabinet heater and lighting and motor heater \(options +G300, +G301 and +G313\)](#)
- [Auxiliary circuit power consumption](#) on page 207
- circuit diagrams delivered with drive for the actual wiring.

■ Terminals for external uninterruptible control voltage (option +G307)

The option provides terminals for connecting external uninterruptible control voltage to the control unit and control devices when the drive is not powered.

See also

- [Supplying power for the auxiliary circuits](#) on page 87
 - [Connecting the external 230 V or 115 V uninterruptible control voltage \(UPS, option +G307\)](#) on page 114
 - circuit diagrams delivered with drive for the actual wiring.
-

■ Output for motor space heater (option +G313)

The option contains:

- load switch for providing electrical isolation during service
- miniature circuit breaker for overcurrent protection
- terminal block for external supply and heating element(s) connection



The heater is off when the drive is running. The customer controls the heating elements in the motor windings on and off with the external supply. The power and voltage of the motor heater depend on the motor.

See also

- [Supplying power for the auxiliary circuits](#) on page 87
- [Connecting the external power supply cables for the cabinet heater and lighting and motor heater \(options +G300, +G301 and +G313\)](#) on page 117
- circuit diagrams delivered with drive for the actual wiring.

■ Additional wire markings (options +G340 and +G342)

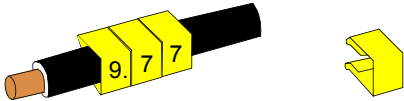
As standard, drive input and output terminals, plug-in connectors, fiber optic connectors and ribbon cables are marked. The wire marking options are described below.

	Additional markings
+G340	<p>Equipment pin numbers are marked with snap-on markers on wires between modules and on wires connected to equipment, terminal blocks and detachable screw terminals. Plug-in connector identifications are marked on labels near the connectors. The label holders are attached around conductor bundles. Main circuit conductors are marked with white tape or printing.</p> 
+G342	<p>Equipment identifications and terminal block pin numbers and remote addresses are marked with tubing or rings on wires between modules, and on wires connected to equipment, terminal blocks and detachable screw terminals. Plug-in connector identifications are marked on labels attached around the conductor bundles near the connectors. Main circuit conductors are marked with white tape or printing.</p> <p>Note: Even wires with equipment and pin identifiers ready printed on the wire insulation are marked with rings or tubing. Remote end addresses are not marked on wire ends that are connected to plug-in connectors. Short and obvious connections are marked with printing only. .</p> 

■ US/UK gland/conduit plate (option +H358)

The option provides US/UK conduit plates (plain 3 mm thick steel plates without any ready-made holes). US/UK conduit plates are provided as standard with options +C129 and +C134 instead of the standard cable entries.

■ Additional terminal block X504 (option +L504)

The standard terminal blocks of the drive control unit are wired to the additional terminal block at the factory for customer control wiring. The terminals are spring loaded.

Cables accepted by the terminals:

- solid wire 0.08 to 4 mm² (28 to 12 AWG)
- stranded wire with ferrule 0.14 to 2.5 mm² (24 to 14 AWG)
- stranded wire without ferrule 0.08 to 2.5 mm² (28 to 14 AWG).

Stripping length: 10 mm (0.5 in).

Note: The option modules inserted in the slots of the control unit are not wired to the additional terminal block. The customer must connect the option module control wires directly to the modules.

■ Thermistor relays (options +L505, +2L505)

The thermistor relay is used for the overtemperature supervision of motors equipped with PTC thermistors. When the motor temperature rises to the thermistor wake-up level, the thermistor resistance increases sharply. The relay detects the change and indicates motor overtemperature through its auxiliary contacts.

Option +L505 provides a thermistor relay and an auxiliary relay and connection terminals for one measuring circuit (one PTC thermistor) and for one normally open contact. The relay can be reset by pressing its reset button or the resetting can be wired externally.

Option +2L505 provides two thermistor relays and auxiliary relays and connection terminals for two measuring circuit (one PTC thermistor in each) and for two normally open contacts. The relays can be reset locally or from a remote reset switch wired to the relay.

The customer connects PTC sensors to the thermistor relay and the terminals of the auxiliary relay of the normally open contact, for example, to

- main breaker control circuit of the drive for opening the breaker in case of motor overtemperature or
- appropriate digital input of the drive for tripping the drive and generating a fault message in case of motor overtemperature or
- customer control circuit.

See also

- firmware manual for parameter settings
- [Wiring the thermistor relay\(s\) \(options +L505 and +2L505\)](#) on page 115
- circuit diagrams delivered with the drive for the actual wiring.

■ Pt100 relays (options +3L506, +5L506, +8L506)

What the option contains

The standard Pt100 relay option includes three (+3L506), five (+5L506) or eight (+8L506) Pt100 temperature monitoring relays and an auxiliary relay wired to a terminal block. Other numbers of Pt100 relays must be ordered as application engineered.

Description

The Pt100 relay is used for the overtemperature supervision of motors equipped with Pt100 sensors. For example, three sensors measure the temperature of the motor windings and two sensors the temperature of the bearings. The sensor resistance increases linearly as the temperature rises. The Pt100 relay releases at an adjustable wake-up level and indicates motor overtemperature through its change-over contact.

The Pt100 relay provides connection terminals for one Pt100 temperature sensor and terminals of one normally open and one normally closed contact.

The customer connects Pt100 sensors to the Pt100 relays (one sensor per relay) and the auxiliary relays of the normally open contacts of the Pt100 relays, for example, to

- main breaker control circuit of the drive for opening the breaker in case of motor overtemperature or
- appropriate digital input of the drive for tripping the drive and generating a fault message in case of motor overtemperature or
- customer control circuit.

See also

- firmware manual for parameter settings
- [Wiring the Pt100 relays \(options +2L506, +3L506, +5L506 and +8L506\)](#) on page 116
- Pt100 relay alarm and trip limit setting instructions on page 143
- circuit diagrams delivered with the drive for the actual wiring.

Type designation label

The type designation label includes an IEC and NEMA rating, appropriate markings, a type designation and a serial number, which allow identification of each unit. The type designation label is located on the front cover. An example label is shown below.

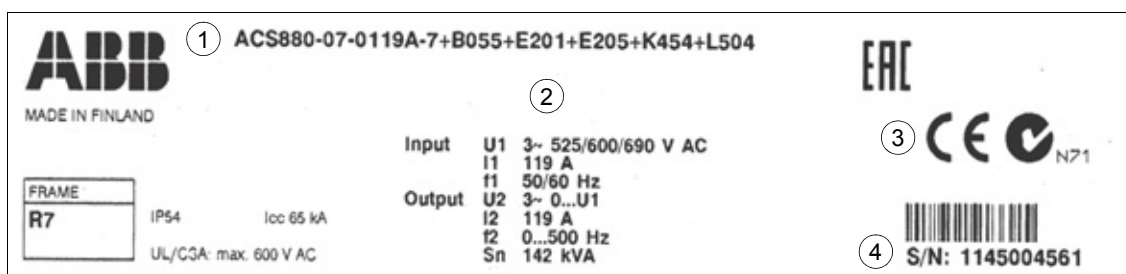

No.	Description
1	Type designation, see section Type designation key below.
2	Ratings
3	Valid markings
4	Serial number. The first digit of the serial number refers to the manufacturing plant. The next four digits refer to the unit's manufacturing year and week, respectively. The remaining digits complete the serial number so that there are no two units with the same number.

Type designation key

The type designation contains information on the specifications and configuration of the drive. The first digits from left express the basic configuration (eg, ACS880-07-240A-5). The optional selections are given thereafter, separated by plus signs, eg, +E202. The main selections are described below. Not all selections are available for all types or with all options. For more information, refer to *ACS880 Ordering Information* (3AXD10000052815, available on request).

CODE	DESCRIPTION
Basic codes	
ACS880	Product series
07	When no options are selected: cabinet-installed drive, IP22 (UL Type 1), main switch-disconnector (switch fuse with aR fuses), ACS-AP-I assistant control panel, no EMC filter, input DC choke (frames R6 to R9), input AC choke (frames R10 and R11), coated boards, ACS880 primary control program, Safe torque off function, bottom entry and exit of cables, multilingual device label sticker, USB memory stick containing USB memory stick containing circuit diagrams and all manuals.
Size	
xxxx	Refer to the rating tables, page 183
Voltage range	
3	380...415 V. This is indicated in the type designation label as typical input voltage level 3 ~ 400 V AC.
5	380...500 V. This is indicated in the type designation label as typical input voltage levels 3 ~ 400/480/500 V AC.
7	525...690 V. This is indicated in the type designation label as typical input voltage levels 3 ~ 525/600/690 V AC.
Option codes (plus codes)	
Degree of protection	
B054	IP42 (UL Type 1)
B055	IP54 (UL Type 12)
Construction	
C121	Marine construction (page 44)
C134	CSA Approved (page 45)
C128	Air inlet through bottom. Requires option +B055. See page 67 .
C130	Channeled air outlet (page 44)
C129	UL Listed (page 45)
C164	Plinth height 100 mm (page 45). Note: IP54 roof with option +B055 is packed in a separate package if the plinth height 100 mm.
C179	Plinth height 200 mm (page 45)
C180	Seismic design (page 45)
Resistor braking	
D150	Brake choppers (page 45)
D151	Brake resistors (page 45)
Filters	
E200	EMC filter for second environment TN (grounded) system, category C3. See page 45 .
E201	EMC filter for second environment IT (ungrounded) system, category C3. See page 45 .
E202	EMC filter for first environment TN (grounded) system, category C2. See page 45 .
E205	du/dt filter (page 45)
E210	EMC filter for second environment TN and IT (grounded and ungrounded) systems, category C3. See page 45 .
E206	Sine output filter (page 46)
E208	Common mode filter (page 46)
Line options	
F250	Line contactor
F277	Flange mounted switch for molded case circuit breaker (MCCB) for US market only
F289	Molded case circuit breaker (MCCB) for US market only

CODE	DESCRIPTION
Heaters and auxiliary control voltage	
G300	Cabinet heater (external supply). See page 46.
G307	Terminals for connecting external control voltage (230 V AC or 115 V uninterruptible power supply)
G313	Output for motor heater (external supply)
Lights	
G301	Cabinet lighting
G327	Ready pilot light, white
G328	Run pilot light, green
G329	Fault pilot light, red
Materials	
G330	Halogen-free wiring and materials. Not available with +C129 and +C134.
Meters	
G334	V-meter with selector switch
G335	A-meter in one phase
Wire markings	
G340	See section <i>Additional wire markings (options +G340 and +G342)</i> on page 47.
G342	
Cabling	
H350	Bottom entry (only with +C129)
H352	Bottom exit (only with +C129)
H351	Top entry of cables (included with +C129)
H353	Top exit of cables (included with +C129)
H356	DC cable connection busbars
H358	Cable conduit entry (included with +C129 and +C134). See page 47.
Fieldbus adapters	
K451	FDNA-01 DeviceNet™ adapter module
K452	FLON-01 LonWorks® adapter module
K454	FPBA-01 PROFIBUS DP adapter module
K457	FCAN-01 CANopen adapter module
K458	FSCA-01 RS-485 adapter module
K462	FCNA-01 ControlNet™ adapter module
K469	FECA EtherCat adapter module
K470	FEPL EtherPOWERLINK adapter module
K473	FENA-11 Ethernet adapter module for EtherNet/IP™, Modbus TCP and PROFINET IO protocols
K475	FENA-21 Ethernet adapter module for EtherNet/IP™, Modbus TCP and PROFINET IO protocols, 2-port
I/O extensions and feedback interfaces	
L500	FIO-11 analog I/O extension module
L501	FIO-01 digital I/O extension module
L502	FEN-31 HTL incremental encoder interface module
L503	FDCO-01 optical DDCS communication adapter module
L508	FDCO-02 optical DDCS communication adapter module
L504	Additional I/O terminal block
L505	Thermistor relay (one or two pcs)
L506	Pt100 relay (2, 3, 5 or 8 pcs)

CODE	DESCRIPTION
L513	ATEX-certified thermal protection with PTC sensors (one or two pcs, +Q971 required)
L514	ATEX-certified thermal protection with Pt100 relays (2, 3, 5 or 8 pcs, +Q971 required)
L515	FEA-03 I/O extension adapter
L516	FEN-21 resolver interface module
L517	FEN-01 TTL incremental encoder interface module
L518	FEN-11 TTL absolute encoder interface module
L525	FAIO-01 analog I/O extension module
L526	FDIO-01 digital I/O extension module
Starter for auxiliary motor fan	
M600	Trip limit setting range: 1...1.6 A
M601	Trip limit setting range: 1.6...2.5 A
M602	Trip limit setting range: 2.5...4 A
M603	Trip limit setting range: 4...6.3 A
M604	Trip limit setting range: 6.3...10 A
Control program	
N7502	Control program for synchronous reluctance motors (SynRM)
N8010	IEC 61131-3 application programmability
M605	Trip limit setting range: 10...16 A
Specialties	
P902	Customized
P904	Extended warranty
P912	Seaworthy packing
P913	Special color
P929	Container packing
Safety functions	
Q950	Prevention of unexpected start with FSO-xx
Q951	Emergency stop of Category 0 with opening the main contactor or breaker
Q952	Emergency stop of Category 1 with opening the main contactor or breaker
Q954	Ground fault monitoring for IT (ungrounded) systems
Q957	Prevention of unexpected start with safety relay
Q963	Emergency stop of Category 0 with safety relay (without opening the main contactor or breaker)
Q964	Emergency stop of Category 1 with safety relay (without opening the main contactor or breaker)
Q971	ATEX-certified Safe disconnection function, EX II (2) GD. Requires +L513 or +L514.
Q972	FSO-21 safety functions module
Q973	FSO-12 safety functions module.
Q978	Emergency stop (configurable for category 0 or 1) with FSO-xx safety functions module, by opening the main breaker/contactor
Q979	Emergency stop (configurable for category 0 or 1) with FSO-xx safety functions module, by activating the Safe torque off function
Q982	PROFIsafe with FSO-xx safety functions module and FENA-21 Ethernet adapter module
Printed documentation (manuals, dimensional drawings, circuit diagrams and manual language). Note: The delivered manual set may include manuals in English if the translation is not available.	
R700	English
R701	German
R702	Italian
R703	Dutch

CODE	DESCRIPTION
R704	Danish
R705	Swedish
R706	Finnish
R707	French
R708	Spanish
R709	Portuguese
R711	Russian

4

Mechanical installation

Contents of this chapter

This chapter describes the mechanical installation procedure of the drive.

Examining the installation site

Examine the installation site:

- The installation site is sufficiently ventilated or cooled to transfer away the drive losses. ¹⁾
- The ambient conditions of the drive meet the specifications. ¹⁾
- The wall behind the unit is of non-flammable material.
- There is enough free space above the drive to enable cooling air flow, service and maintenance.
- The floor that the unit is installed on is of non-flammable material, as smooth as possible, and strong enough to support the weight of the unit. Check the floor flatness with a spirit level. The maximum allowed deviation from the surface level is 5 mm (0.2 in) in every 3 meters (10 ft). Level the installation site, if necessary, as the cabinet is not equipped with adjustable feet.

¹⁾ The heat losses and ambient conditions are specified in chapter [Technical data](#).



Note: For easy maintenance, do not install the drives of frames R10 and R11 on a higher level than the floor in front of it. Otherwise the ramp supplied with the drive cannot be used when replacing the drive modules that run on wheels.

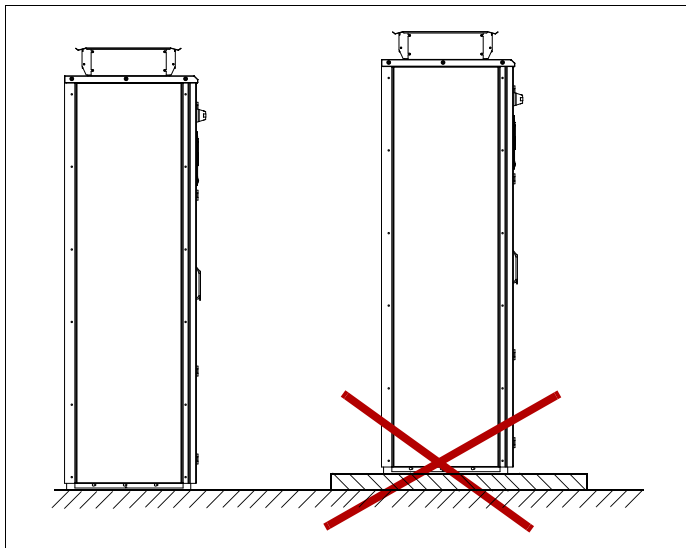

Necessary tools

The tools required for moving the unit to its final position, fastening it to the floor and wall and tightening the connections are listed below:

- crane, fork-lift or pallet truck (check load capacity!), iron bar, jack and rollers
- Pozidriv and Torx (2.5...6 mm) screwdrivers
- torque wrench
- set of wrenches or sockets.



Moving and unpacking the drive

Move the drive in its original pallet, preferably in the original package to installation site as shown below to avoid damaging the cabinet surfaces and door devices. When you use a pallet truck, check its load capacity before you move the drive.

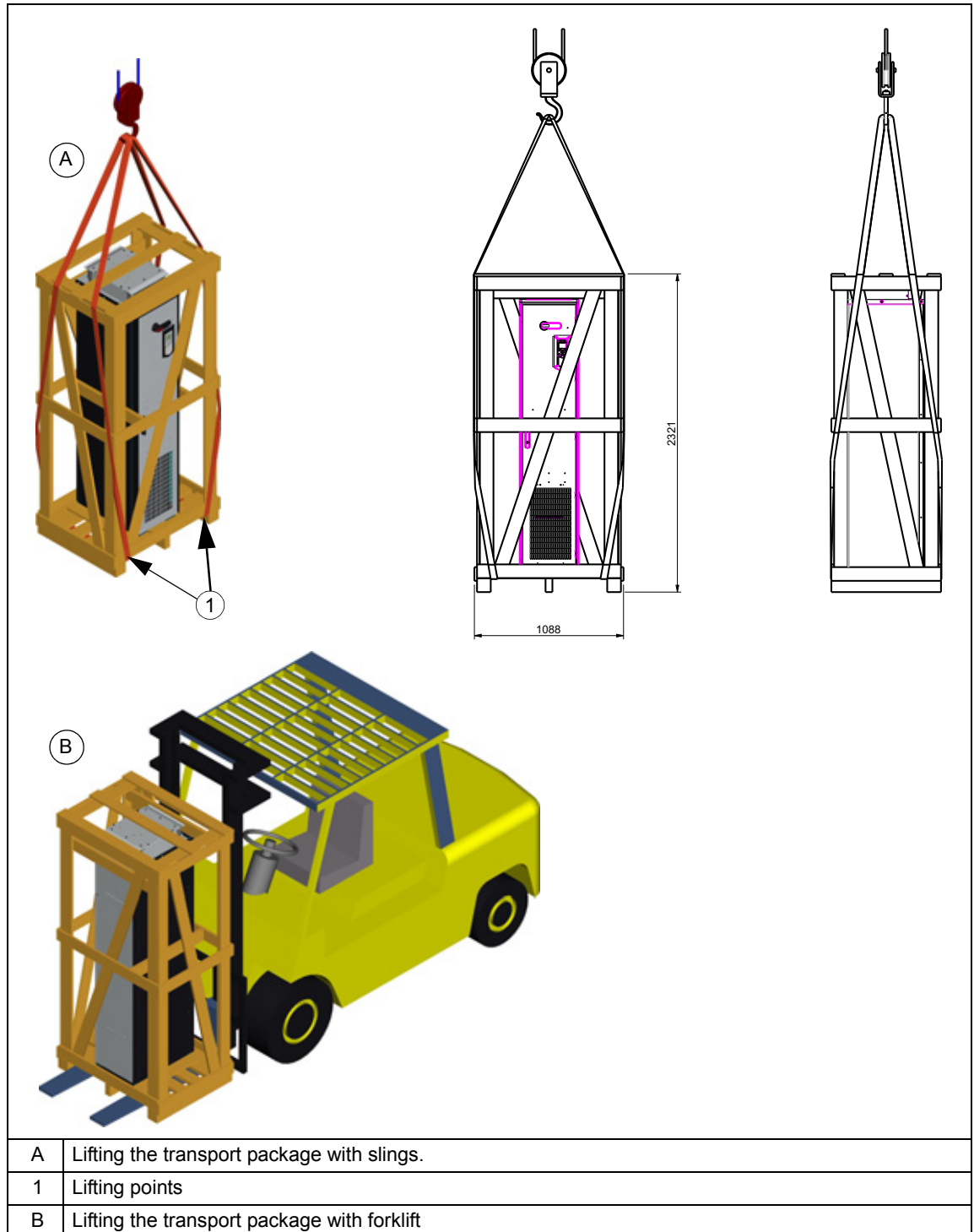

■ Unpacking the transport package

Unpack the transport package as follows:

1. Undo the screws that hold the wooden elements of the transport crate together.
2. Remove the elements.
3. Remove the clamps with which the drive cabinet is mounted onto the transport pallet by undoing the fastening screws.
4. Remove the plastic wrapping.

Checking the delivery

The drive delivery contains:

- drive cabinet line-up
- option modules (if ordered) installed onto the control unit at the factory
- appropriate drive and option module manuals
- delivery documents.

Check that there are no signs of damage. Before attempting installation and operation, check the information on the type designation labels of the drive to verify that the delivery is of the correct type. See section [Type designation key](#) on page 49.

Moving the drive cabinet



Move drive cabinet carefully in the upright position. Avoid tilting. The center of gravity of the cabinet is high.

Transportation of the cabinet on its back is only allowed if it is packed for such transportation at the factory. If the cabinet needs to be laid on its back, support it from below beside the cubicle seams. 1) cabinet back panel; 2) support. Never lay or transport a unit with sine filters (with option code +E206) on its back.

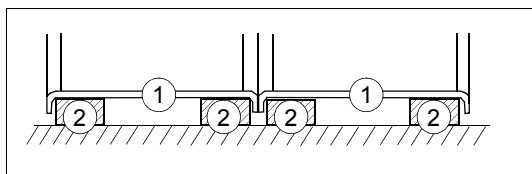

Installing the IP54 roof

If the roof of an IP54 cabinet is delivered in a separate package, install the roof as follows.

■ Frames R6 to R8

1. Undo the mounting screws of the front top profile of the cabinet and remove it. Undo the back mounting screws of the roof from the cabinet top. See step 1 under section [Frames R10 and R11](#) on page 61.
2. Remove the IP54 filter grating and connect the fan power supply wires.

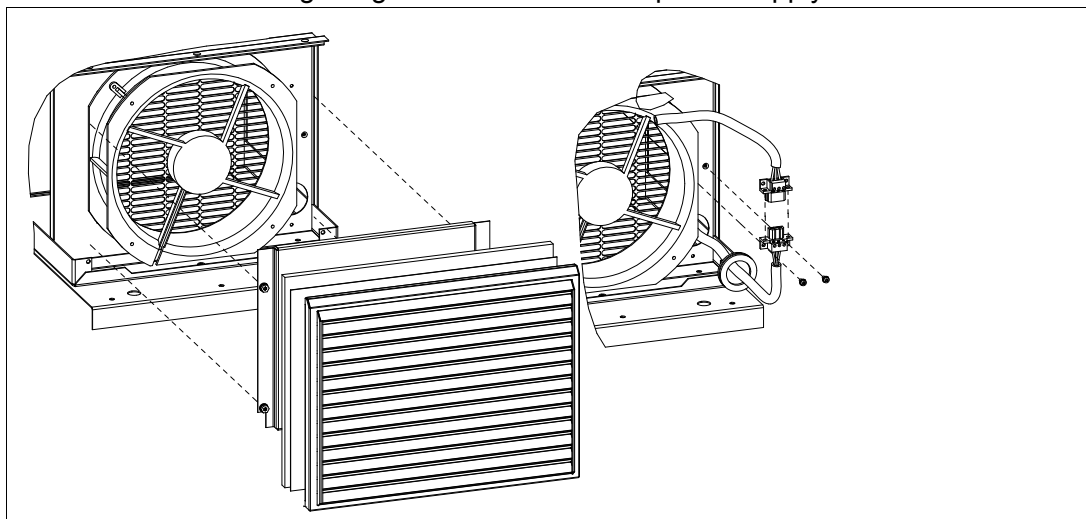

3. Install the front top profile of the cabinet in reverse order to step 1.
4. Fasten the back mounting screws of the roof.
5. Install the IP54 filter grating.



■ Frame R9

1. Undo the mounting screws of the front top profile of the cabinet and remove it. Undo the back mounting screws of the roof from the cabinet top. See step 1 under section [Frames R10 and R11](#) on page 61.
2. Install the shroud to bottom of the fan assembly. Connect the fan supply wires

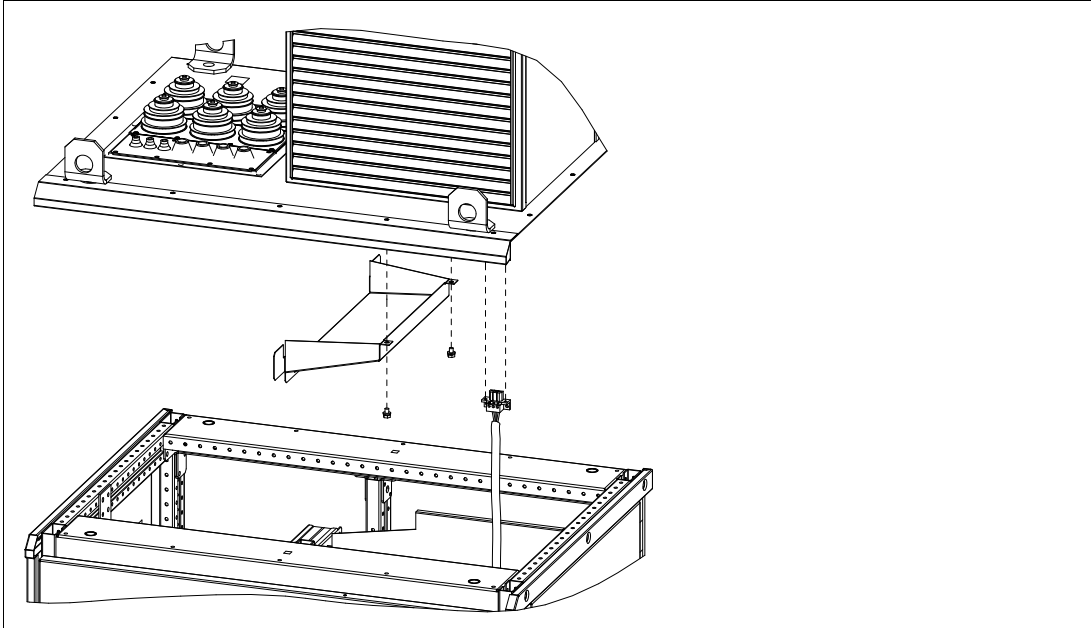

3. Install the front top profile of the cabinet in reverse order to step 1.
4. Fasten the back mounting screws of the roof.



■ **Frames R10 and R11**

1. Undo the mounting screws of the front top profile of the cabinet and remove it. Undo the back mounting screws of the roof from the cabinet top.

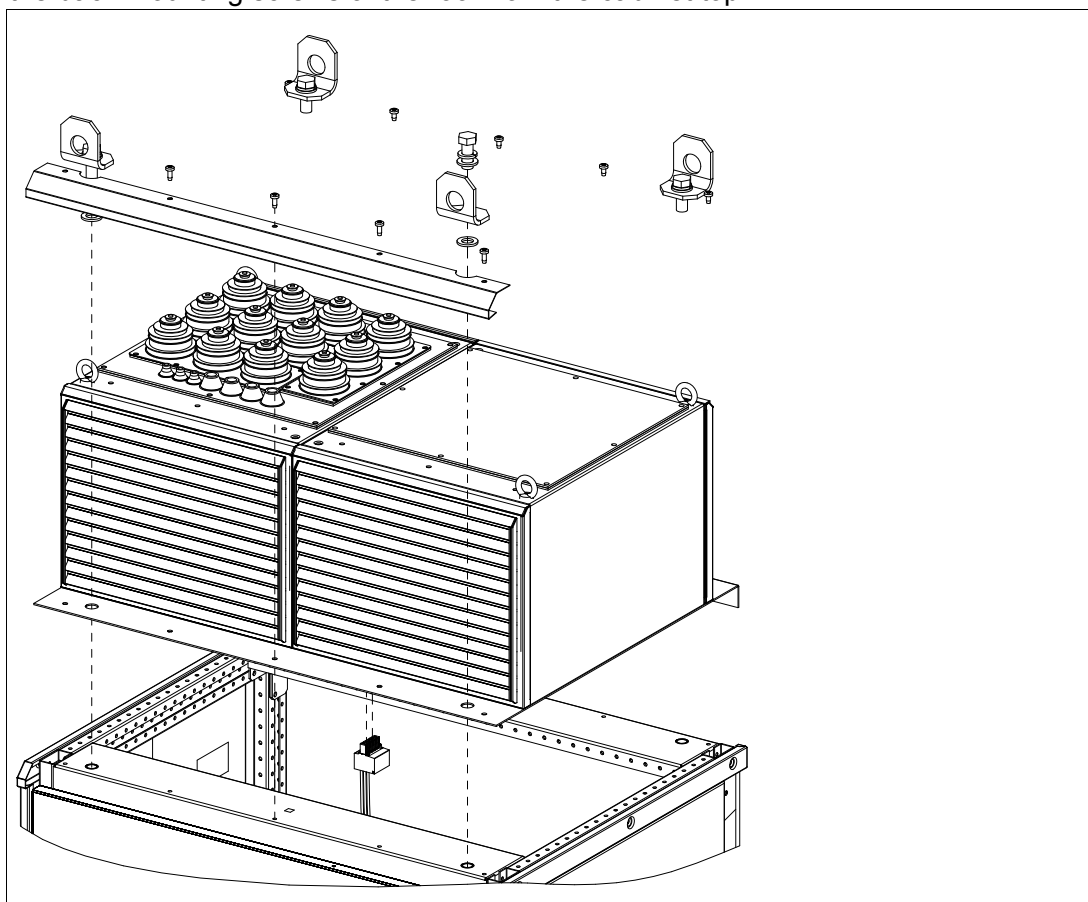

2. Connect the power supply wires to the fan.
3. Install the front top profile of the cabinet in reverse order to step 1.
4. Fasten the back mounting screws of the roof.

■ Lifting the drive cabinet

Lift the drive cabinet using its lifting lugs. Maximum allowed lifting angle of IP22 (UL Type 1) and IP42 (UL Type 1 Filtered) cabinets is 30°. Allowed minimum height of lifting slings of IP54 (UL Type 12) cabinets is 2 meters (6.5 ft).

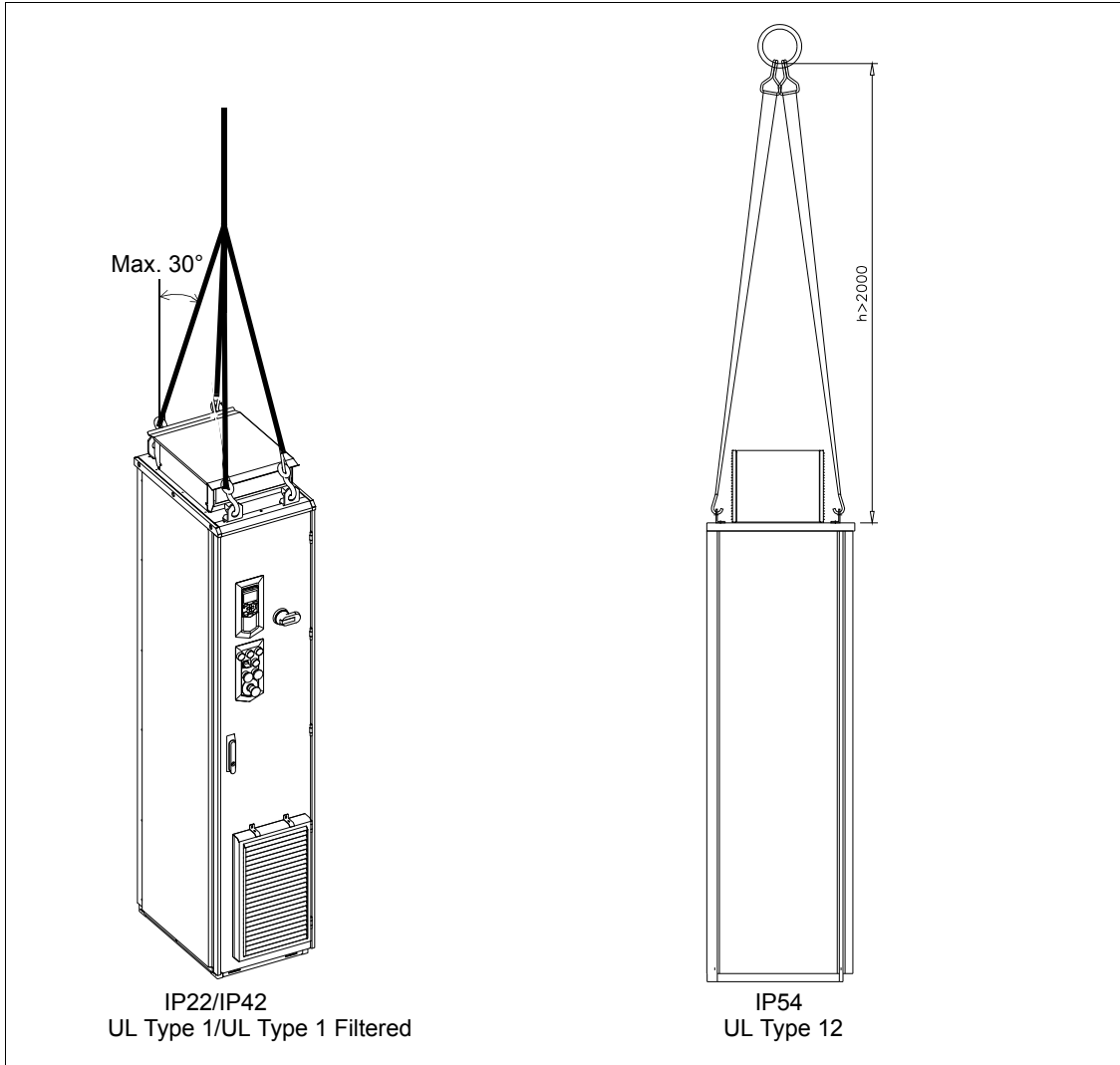

■ Moving the cabinet on rollers

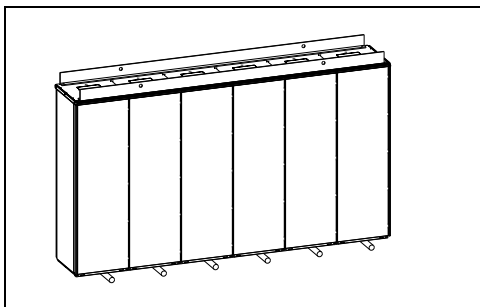

Remove the wooden bottom frame which is part of the shipment.
Lay the cabinet on the rollers and move it carefully until close to its final location.
Remove the rollers by lifting the unit with a crane, fork-lift, pallet truck or jack.

■ Final placement of the cabinet

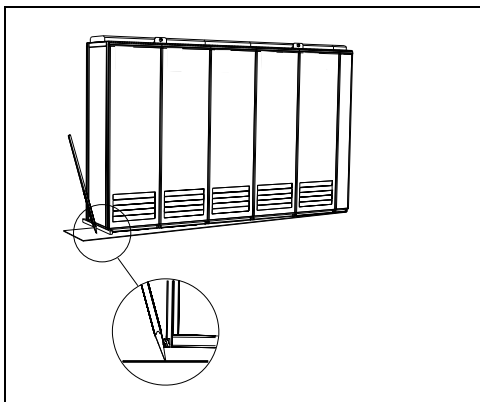

Move the cabinet into its final position with an iron bar. Place a wooden piece at the bottom edge of the cabinet in order not to damage the cabinet frame with the iron bar.



Fastening the cabinet to the floor and wall or roof (non-marine units)

General rules

- The drive must be installed in an upright vertical position.
- The cabinet can be installed with its back against a wall (a), or back-to-back with another unit (b).
- Leave 400 mm (15.75 in) free space above the basic roof level of the cabinet for cooling. IP54 (UL Type 12) fan replacement requires 320 mm (12.6 in) free space above.
- Leave some space at the side where the cabinet outmost hinges are to allow the doors to open sufficiently (w). The doors must open 120° to allow the drive module replacement.

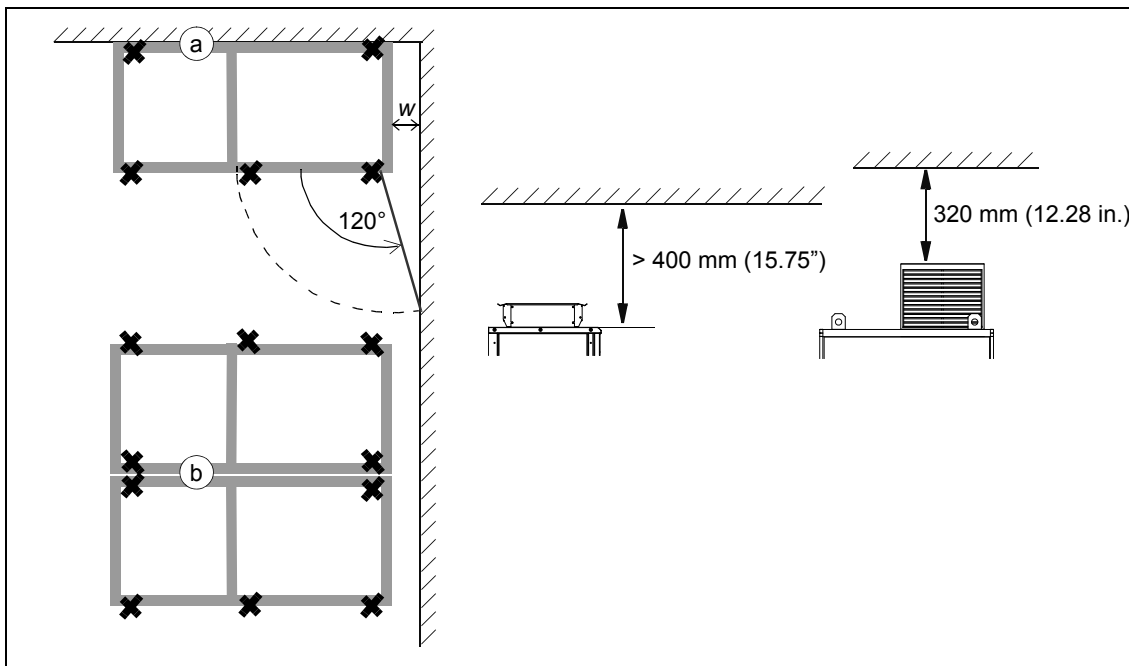

Note 1: Any height adjustment must be done before fastening the units or shipping splits together. Height adjustment can be done by using metal shims between the cabinet bottom and floor.

Note 2: If the lifting eyes are removed, refasten the bolts to retain the degree of protection of the cabinet.

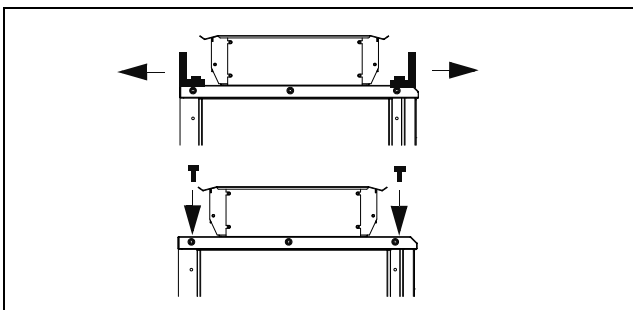

■ **Fastening methods**

Fasten the cabinet to the floor by using clamps along the edge of the cabinet bottom, or by bolting the cabinet to the floor through the holes inside (if they are accessible).

■ **Alternative 1 – Clamping**

	<ol style="list-style-type: none"> 1. Insert the clamps into the twin slots along the front and rear edges of the cabinet frame body and fasten them to the floor with a bolt. The recommended maximum distance between the clamps in the front edge is 800 mm (31.5”). 2. If floor mounting from back is not possible, fasten the cabinet at the top to wall with L-brackets (not included in the delivery) using the lifting bar fastening holes.
<p>Clamp dimensions</p>	

■ **Alternative 2 – Using the holes inside the cabinet**

	<ol style="list-style-type: none"> 1. Fasten the cabinet to the floor through the bottom fastening holes with M10 to M12 (3/8” to 1/2”) bolts. The recommended maximum distance between the front edge fastening points is 800 mm (31.5”). 2. If the back fastening holes are not accessible, fasten the cabinet at the top to wall with L-brackets (not included in the delivery) using the lifting bar fastening holes.

Fastening the cabinet to the floor and roof/wall (marine units)

Follow the general rules given in section [General rules](#) on page 64.

See the dimension drawing delivered with the drive for the locations of the fastening holes in the flat bars below the cabinet and for fastening points at the top of the cabinet. Top fastening brackets are included in the delivery.

Fasten the cabinet to the floor and roof (wall) as follows:

1. Bolt the unit to the floor through the holes in each flat bar at the base of the cabinet using M10 or M12 screws.
2. If there is not enough room behind the cabinet for installation, clamp the rear ends of the flat bars.
3. Remove the lifting lugs and bolt the fastening brackets into the lifting lug holes. Fasten the top of the cabinet to the rear wall and/or roof with brackets.

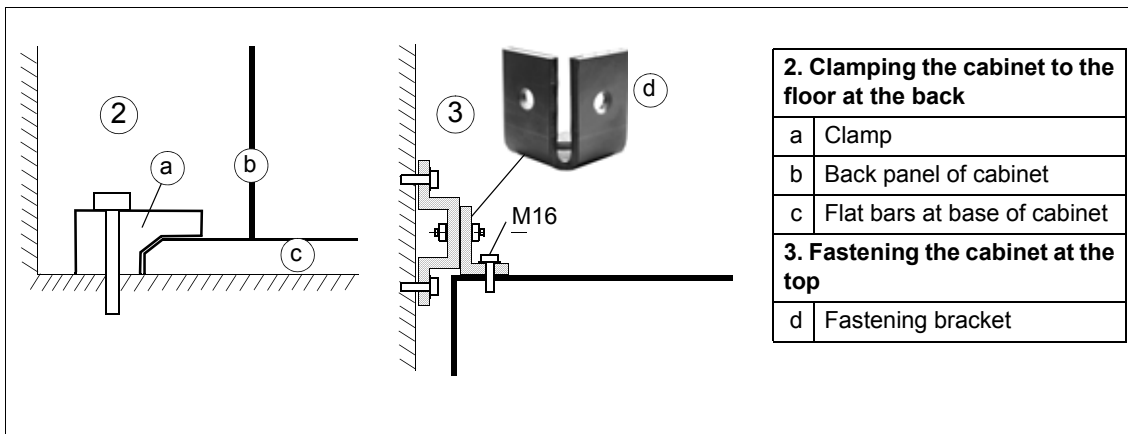

Miscellaneous

■ Cable duct in the floor below the cabinet

A cable duct can be constructed below the 500 mm wide middle part of the cabinet. The cabinet weight lies on the two 50 mm wide transverse sections which the floor must carry.

Prevent the cooling air flow from the cable duct to the cabinet by bottom plates. To ensure the degree of protection for the cabinet, use the original bottom plates delivered with the unit. With user-defined cable entries, take care of the degree of protection, fire protection and EMC compliance.

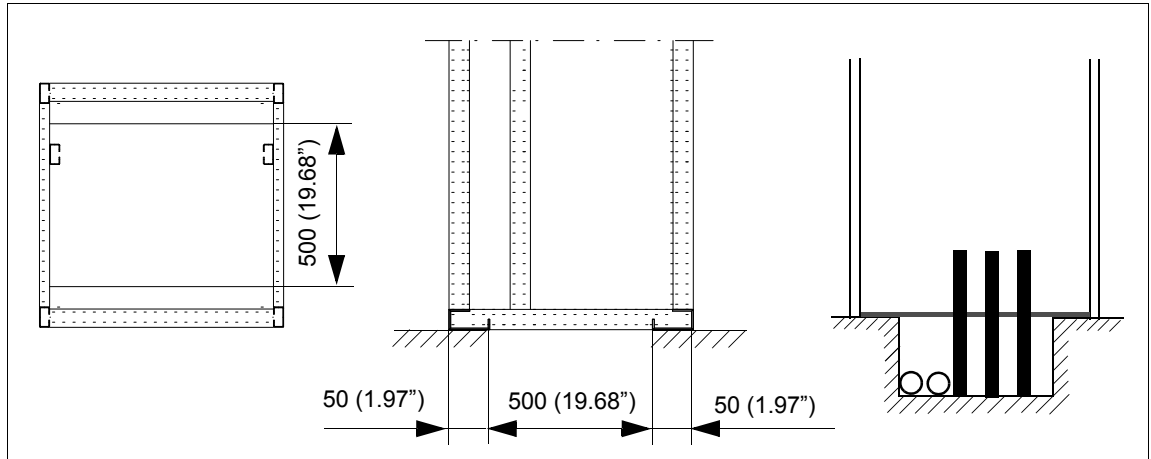

■ Air inlet through the bottom (option +C128+B055)

Drives with air intake through the bottom of the cabinet (option +C128) are intended for installation on an air duct in the floor. Option +C128 requires also option +B055. An example of the required air inlets in the floor is shown below. Refer also to the dimension drawings delivered with the drive.

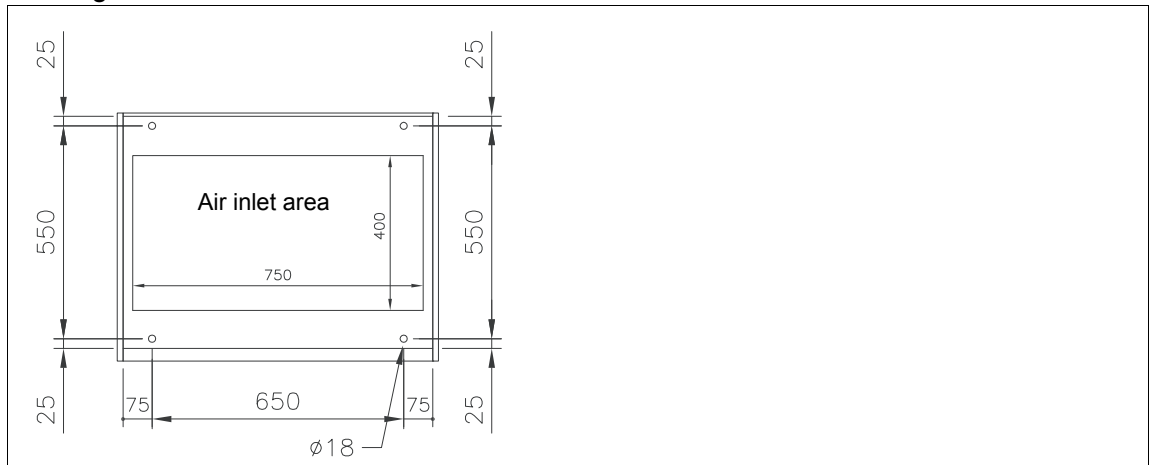

Support the plinth of the cabinet all round.

The air duct must be able to supply a sufficient volume of cooling air. The minimum air flow values are given in section [Losses, cooling data and noise](#) on page 196.



WARNING! Make sure that the incoming air is sufficiently clean. If not, dust goes into the cabinet. The outlet filter on the cabinet roof prevents dust from going out. The collected dust can cause drive malfunction and danger of fire.

■ Air outlet duct on the cabinet roof (option +C130)

The ventilation system must keep the static pressure in the air outlet duct sufficiently below the pressure of the room where the drive is located in order that the cabinet fans can produce the required air flow through the cabinet. Make sure that no dirty or moist air is able to flow backward to the drive in any case, even during off-time or while servicing the drive or the ventilation system.

Calculating the required static pressure difference

The required static pressure difference between the exit air duct and the drive installation room can be calculated as follows:

$$\Delta p_s = (1.5 \dots 2) \cdot p_d$$

where

$$p_d = 0.5 \cdot \rho \cdot v_m^2$$

$$v_m = q / A_c$$

p_d $\hat{=}$ Dynamic pressure

ρ $\hat{=}$ Air density (kg/m³)

v_m $\hat{=}$ Average air velocity in the exit duct(s) (m/s)

q $\hat{=}$ Rated air flow of the drive (m³/s)

A_c $\hat{=}$ Cross-sectional area of the exit duct(s) (m²)

Example

The cabinet has 3 exit openings of 315 mm diameter. The rated air flow of the cabinet is 4650 m³/h = 1.3 m³/s.

$$A_c = 3 \cdot 0.315^2 \cdot \pi / 4 = 0.234 \text{ m}^2$$

$$v_m = q / A_c = 1.3 / 0.234 = 5.5 \text{ m/s}$$

$$p_d = 0.5 \cdot \rho \cdot v_m^2 = 0.5 \cdot 1.1 \cdot 5.5^2 = 17 \text{ Pa}$$

The required pressure in the exit air duct is then, 1.5...2 • 17 Pa = 26...34 Pa, below the pressure in the room.

For more information: Contact ABB.

■ Arc welding

Fastening the cabinet by arc welding is not recommended. However, if the arc welding is the only mounting option, proceed as follows: Connect the return conductor of the welding equipment to the cabinet frame at the bottom within 0.5 meters (1.5 ft) of the welding point.

Note: The thickness of the zinc coating of the cabinet frame is 100 to 200 micrometers.



WARNING! Make sure that the return wire is connected correctly. Welding current must not return via any component or cabling of the drive. If the welding return wire is connected improperly, the welding circuit can damage electronic circuits in the cabinet.



WARNING! Do not inhale the welding fumes.





5

Guidelines for planning the electrical installation

Contents of this chapter

This chapter contains instructions for planning the electrical installation of the drive. Some instructions are mandatory to follow in every installation, others provide useful information that only concerns certain applications.

Limitation of liability

The installation must always be designed and made according to applicable local laws and regulations. ABB does not assume any liability whatsoever for any installation which breaches the local laws and/or other regulations. Furthermore, if the recommendations given by ABB are not followed, the drive may experience problems that the warranty does not cover.

Selecting the supply disconnecting device

The drive is equipped with a main switch-disconnector as standard. The disconnector can be locked to the open position for installation and maintenance work.

Selecting the main contactor

The drive can be equipped with a line contactor (option +F250).

Examining the compatibility of the motor and drive

Use an asynchronous AC induction motor, permanent magnet synchronous motor, AC induction servomotor or ABB synchronous reluctance motor (SynRM motor) with the drive. Several induction motors can be connected to the drive at a time.

Select the motor size and drive type from the rating tables in chapter [Technical data](#) on basis of the AC line voltage and motor load. Use the DriveSize PC tool if you need to tune the selection more in detail.

Make sure that the motor withstands the maximum peak voltage in the motor terminals. See the [Requirements table](#) on page 73. For basics of protecting the motor insulation and bearings in drive systems, refer to section [Protecting the motor insulation and bearings](#) below.

Note:

- Consult the motor manufacturer before using a motor whose nominal voltage differs from the AC line voltage connected to the drive input.
- The voltage peaks at the motor terminals are relative to the supply voltage of the drive, not the drive output voltage.
- If the motor and drive are not of the same size, consider the following operation limits of the drive control program:
 - motor nominal voltage range $1/6 \dots 2 \cdot U_N$
 - motor nominal current range $1/6 \dots 2 \cdot I_N$ of the drive in DTC control and $0 \dots 2 \cdot I_N$ in scalar control. The control mode is selected by a drive parameter.

■ Protecting the motor insulation and bearings

The drive employs modern IGBT inverter technology. Regardless of frequency, the drive output comprises pulses of approximately the drive DC bus voltage with a very short rise time. The pulse voltage can almost double at the motor terminals, depending on the attenuation and reflection properties of the motor cable and the terminals. This can cause additional stress on the motor and motor cable insulation.

Modern variable speed drives with their fast rising voltage pulses and high switching frequencies can generate current pulses that flow through the motor bearings. This can gradually erode the bearing races and rolling elements.

Optional du/dt filters protect motor insulation system and reduce bearing currents. Optional common mode filters mainly reduce bearing currents. Insulated N-end (non-drive end) bearings protect the motor bearings.

■ Requirements table

The following table shows how to select the motor insulation system and when an optional drive du/dt and common mode filters and insulated N-end (non-drive end) motor bearings are required. Ignoring the requirements or improper installation may shorten motor life or damage the motor bearings and voids the warranty.

Motor type	Nominal AC supply voltage	Requirement for			
		Motor insulation system	ABB du/dt and common mode filters, insulated N-end motor bearings		
			$P_N < 100$ kW and frame size < IEC 315	100 kW $\leq P_N < 350$ kW or IEC 315 \leq frame size < IEC 400	$P_N \geq 350$ kW or frame size \geq IEC 400
			$P_N < 134$ hp and frame size < NEMA 500	134 hp $\leq P_N < 469$ hp or NEMA 500 \leq frame size \leq NEMA 580	$P_N \geq 469$ hp or frame size > NEMA 580
ABB motors					
Random-wound M2_, M3_ and M4_	$U_N \leq 500$ V	Standard	-	+ N	+ N + CMF
	500 V $< U_N \leq 600$ V	Standard	+ du/dt	+ N + du/dt	+ N + du/dt + CMF
		or	Reinforced	-	+ N
	600 V $< U_N \leq 690$ V (cable length ≤ 150 m)	Reinforced	+ du/dt	+ N + du/dt	+ N + du/dt + CMF
	600 V $< U_N \leq 690$ V (cable length > 150 m)	Reinforced	-	+ N	+ N + CMF
Form-wound HX_ and AM_	380 V $< U_N \leq 690$ V	Standard	n.a.	+ N + CMF	$P_N < 500$ kW: +N + CMF
					$P_N \geq 500$ kW +N + du/dt + CMF
Old* form-wound HX_ and modular	380 V $< U_N \leq 690$ V	Check with the motor manufacturer.	+ N + du/dt with voltages over 500 V + CMF		
Random-wound HX_ and AM_**	0 V $< U_N \leq 500$ V	Enamelled wire with fiber glass taping	+ N + CMF		
	500 V $< U_N \leq 690$ V		+ N + du/dt + CMF		
HDP	Consult the motor manufacturer.				

* manufactured before 1.1.1998

** For motors manufactured before 1.1.1998, check for additional instructions with the motor manufacturer.

Motor type	Nominal AC supply voltage	Requirement for			
		Motor insulation system	ABB du/dt and common mode filters, insulated N-end motor bearings		
			$P_N < 100$ kW and frame size < IEC 315	$100 \text{ kW} \leq P_N < 350$ kW or IEC 315 \leq frame size < IEC 400	$P_N \geq 350$ kW or frame size \geq IEC 400
$P_N < 134$ hp and frame size < NEMA 500	$134 \text{ hp} \leq P_N < 469$ hp or NEMA 500 \leq frame size \leq NEMA 580	$P_N \geq 469$ hp or frame size > NEMA 580			
Non-ABB motors					
Random-wound and form-wound	$U_N \leq 420$ V	Standard: $\dot{U}_{LL} = 1300$ V	-	+ N or CMF	+ N + CMF
	$420 \text{ V} < U_N \leq 500$ V	Standard: $\dot{U}_{LL} = 1300$ V	+ du/dt	+ du/dt + (N or CMF)	+ N + du/dt + CMF
		or	Reinforced: $\dot{U}_{LL} = 1600$ V, 0.2 microsecond rise time	-	+ N or CMF
	$500 \text{ V} < U_N \leq 600$ V	Reinforced: $\dot{U}_{LL} = 1600$ V	+ du/dt	+ du/dt + (N or CMF)	+ N + du/dt + CMF
		or	Reinforced: $\dot{U}_{LL} = 1800$ V	-	+ N or CMF
	$600 \text{ V} < U_N \leq 690$ V	Reinforced: $\dot{U}_{LL} = 1800$ V	+ du/dt	+ du/dt + N	+ N + du/dt + CMF
Reinforced: $\dot{U}_{LL} = 2000$ V, 0.3 microsecond rise time ***		-	N + CMF	+ N + CMF	

*** If the intermediate DC circuit voltage of the drive is increased from the nominal level by resistor braking, check with the motor manufacturer if additional output filters are needed in the applied drive operation range.

The abbreviations used in the table are defined below.

Abbr.	Definition
U_N	Nominal AC line voltage
\dot{U}_{LL}	Peak line-to-line voltage at motor terminals which the motor insulation must withstand
P_N	Motor nominal power
du/dt	du/dt filter at the output of the drive (option +E205)
CMF	Common mode filter (option +E208)
N	N-end bearing: insulated motor non-drive end bearing
n.a.	Motors of this power range are not available as standard units. Consult the motor manufacturer.

Additional requirements for explosion-safe (EX) motors

If you will use an explosion-safe (EX) motor, follow the rules in the requirements table above. In addition, consult the motor manufacturer for any further requirements.

Additional requirements for ABB motors of types other than M2_, M3_, M4_, HX_ and AM_

Use the selection criteria given for non-ABB motors.

Additional requirements for the braking applications

When the motor brakes the machinery, the intermediate circuit DC voltage of the drive increases, the effect being similar to increasing the motor supply voltage by up to 20 percent. Consider this voltage increase when specifying the motor insulation requirements if the motor will be braking a large part of its operation time.

Example: Motor insulation requirement for a 400 V AC line voltage application must be selected as if the drive were supplied with 480 V.

Additional requirements for ABB high-output and IP23 motors

The rated output power of high output motors is higher than what is stated for the particular frame size in EN 50347 (2001). This table shows the requirements for ABB random-wound motor series (for example, M3AA, M3AP and M3BP).

Nominal mains voltage (AC line voltage)	Requirement for			
	Motor insulation system	ABB du/dt and common mode filters, insulated N-end motor bearings		
		$P_N < 100 \text{ kW}$	$100 \text{ kW} \leq P_N < 200 \text{ kW}$	$P_N \geq 200 \text{ kW}$
		$P_N < 140 \text{ hp}$	$140 \text{ hp} \leq P_N < 268 \text{ hp}$	$P_N \geq 268 \text{ hp}$
$U_N \leq 500 \text{ V}$	Standard	-	+ N	+ N + CMF
$500 \text{ V} < U_N \leq 600 \text{ V}$	Standard	+ du/dt	+ N + du/dt	+ N + du/dt + CMF
	or			
$600 \text{ V} < U_N \leq 690 \text{ V}$	Reinforced	-	+ N	+ N + CMF
	Reinforced	+ du/dt	+ N + du/dt	+ N + du/dt + CMF

Additional requirements for non-ABB high-output and IP23 motors

The rated output power of high output motors is higher than what is stated for the particular frame size in EN 50347 (2001). The table below shows the requirements for random-wound and form-wound non-ABB motors with nominal power smaller than 350 kW. For bigger motors, consult the motor manufacturer.

Nominal AC line voltage	Motor insulation system	Requirement for	
		ABB du/dt filter, insulated N-end bearing and ABB common mode filter	
		$P_N < 100$ kW or frame size $< \text{IEC 315}$	$100 \text{ kW} \leq P_N < 350$ kW or $\text{IEC 315} \leq \text{frame size} < \text{IEC 400}$
		$P_N < 134$ hp or frame size $< \text{NEMA 500}$	$134 \text{ hp} \leq P_N < 469$ hp or $\text{NEMA 500} \leq \text{frame size} \leq \text{NEMA 580}$
$U_N \leq 420$ V	Standard: $\hat{U}_{LL} = 1300$ V	+ N or CMF	+ N + CMF
$420 \text{ V} < U_N \leq 500$ V	Standard: $\hat{U}_{LL} = 1300$ V	+ du/dt + (N or CMF)	+ N + du/dt + CMF
	or		
$500 \text{ V} < U_N \leq 600$ V	Reinforced: $\hat{U}_{LL} = 1600$ V, 0.2 microsecond rise time	+ N or CMF	+ N + CMF
	or		
$600 \text{ V} < U_N \leq 690$ V	Reinforced: $\hat{U}_{LL} = 1600$ V	+ du/dt + (N or CMF)	+ N + du/dt + CMF
	or		
$600 \text{ V} < U_N \leq 690$ V	Reinforced: $\hat{U}_{LL} = 1800$ V	+ N or CMF	+ N + CMF
	or		
$600 \text{ V} < U_N \leq 690$ V	Reinforced: $\hat{U}_{LL} = 1800$ V	+ N + du/dt	+ N + du/dt + CMF
	Reinforced: $\hat{U}_{LL} = 2000$ V, 0.3 microsecond rise time ***	+ N + CMF	+ N + CMF

*** If the intermediate DC circuit voltage of the drive is increased from the nominal level by resistor braking, check with the motor manufacturer if additional output filters are needed in the applied drive operation range.

Additional data for calculating the rise time and the peak line-to-line voltage

If you need to calculate the actual peak voltage and voltage rise time considering the actual cable length, proceed as follows:

- Peak line-to-line voltage: Read the relative \hat{U}_{LL}/U_N value from the appropriate diagram below and multiply it by the nominal supply voltage (U_N).
- Voltage rise time: Read the relative values \hat{U}_{LL}/U_N and $(du/dt)/U_N$ from the appropriate diagram below. Multiply the values by the nominal supply voltage (U_N) and substitute into equation $t = 0.8 \cdot \hat{U}_{LL}/(du/dt)$.

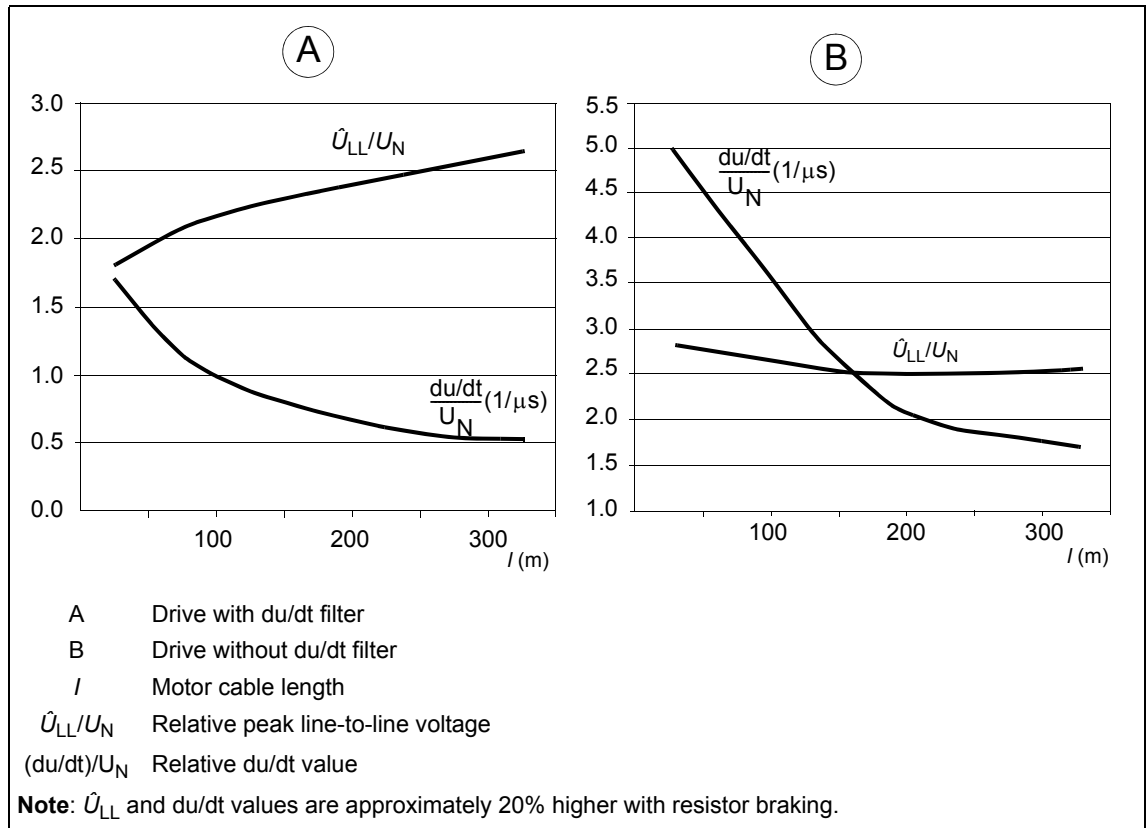

Additional note for sine filters

Sine filters protect the motor insulation system. Therefore, du/dt filter can be replaced with a sine filter. The peak phase-to-phase voltage with the sine filter is approximately $1.5 \cdot U_N$.

Selecting the power cables

■ General rules

Select the input power and motor cables according to local regulations:

- Select a cable capable of carrying the drive nominal current. See section [Ratings](#) (page [183](#)) for the rated currents.
- Select a cable rated for at least 70 °C maximum permissible temperature of conductor in continuous use. For US, see [Additional US requirements](#), page [81](#).
- The inductance and impedance of the PE conductor/cable (grounding wire) must be rated according to permissible touch voltage appearing under fault conditions (so that the fault point voltage will not rise excessively when a ground fault occurs).
- 600 V AC cable is accepted for up to 500 V AC. 750 V AC cable is accepted for up to 600 V AC. For 690 V AC rated equipment, the rated voltage between the conductors of the cable should be at least 1 kV.

Use symmetrical shielded motor cable (see page [80](#)). Ground motor cable shields 360° at both ends. Keep the motor cable and its PE pigtail (twisted shield) as short as possible to reduce high-frequency electromagnetic emissions.

Note: When continuous metal conduit is employed, shielded cable is not required. The conduit must have bonding at both ends.

A four-conductor system is allowed for input cabling, but shielded symmetrical cable is recommended.

Compared to a four-conductor system, the use of symmetrical shielded cable reduces electromagnetic emission of the whole drive system as well as the stress on motor insulation, bearing currents and wear.

The protective conductor must always have an adequate conductivity. The table below shows the minimum cross-sectional area related to the phase conductor size according to IEC 61439-1 when the phase conductor and the protective conductor are made of the same metal.

Cross-sectional area of the phase conductors S (mm ²)	Minimum cross-sectional area of the corresponding protective conductor S_p (mm ²)
$S \leq 16$	S
$16 < S \leq 35$	16
$35 < S \leq 400$	$S/2$
$400 < S \leq 800$	200

■ Typical power cable sizes

The table below gives copper and aluminum cable types with concentric copper shield for the drives with nominal current. For the cable sizes accepted by the drive cabinet lead-throughs and connection terminals, see page 198.

Drive type	Frame size	IEC ¹⁾		US ²⁾
		Cu cable type	Al cable type	Cu cable type
		mm ²	mm ²	AWG/kcmil per phase
<i>U_N</i> = 400 V				
ACS880-07-0105A-3	R6	3×50	3×70	1
ACS880-07-0145A-3	R6	3×95	3×120	2/0
ACS880-07-0169A-3	R7	3×120	3×150	3/0
ACS880-07-0206A-3	R7	3×150	3×240	250 MCM
ACS880-07-0246A-3	R8	2 × (3×70)	2 × (3×95)	300 MCM
ACS880-07-0293A-3	R8	2 × (3×95)	2 × (3×120)	2 × 3/0
ACS880-07-0363A-3	R9	2 × (3×120)	2 × (3×185)	2 × 4/0
ACS880-07-0430A-3	R9	2 × (3×150)	2 × (3×240)	2 × 250 MCM
ACS880-07-0505A-3	R10	3 × (3×95)	3 × (3×150)	2×500 MCM or 3×250 MCM
ACS880-07-0585A-3	R10	3 × (3×120)	3 × (3×185)	2×600 MCM or 3×300 MCM
ACS880-07-0650A-3	R10	3 × (3×150)	3 × (3×240)	2×700 MCM or 3×350 MCM
ACS880-07-0725A-3	R11	3 × (3×185)	4 × (3×185)	3×500 MCM or 4×300 MCM
ACS880-07-0820A-3	R11	3 × (3×240)	4 × (3×240)	3×600 MCM or 4×400 MCM
ACS880-07-0880A-3	R11	3 × (3×240)	4 × (3×240)	3×600 MCM or 4×400 MCM
<i>U_N</i> = 500 V				
ACS880-07-0096A-5	R6	3×50	3×70	1
ACS880-07-0124A-5	R6	3×95	3×95	2/0
ACS880-07-0156A-5	R7	3×120	3×150	3/0
ACS880-07-0180A-5	R7	3×150	3×185	250 MCM
ACS880-07-0240A-5	R8	2 × (3×70)	2 × (3×95)	300 MCM
ACS880-07-0260A-5	R8	2 × (3×70)	2 × (3×95)	2 × 2/0
ACS880-07-0302A-5	R9	2 × (3×120)	2 × (3×185)	2 × 250 MCM
ACS880-07-0361A-5	R9	2 × (3×120)	2 × (3×185)	2 × 250 MCM
ACS880-07-0414A-5	R9	2 × (3×150)	2 × (3×240)	2 × 250 MCM
ACS880-07-0460A-5	R10	3 × (3×95)	3 × (3×150)	2×400 MCM or 3×4/0
ACS880-07-0503A-5	R10	3 × (3×95)	3 × (3×150)	2×500 MCM or 3×250 MCM
ACS880-07-0583A-5	R10	3 × (3×120)	3 × (3×185)	2×600 MCM or 3×300 MCM
ACS880-07-0635A-5	R10	3 × (3×150)	3 × (3×240)	2×700 MCM or 3×350 MCM
ACS880-07-0715A-5	R11	4 × (3×185)	4 × (3×185)	3×500 MCM or 4×300 MCM
ACS880-07-0820A-5	R11	4 × (3×240)	4 × (3×240)	3×600 MCM or 4×400 MCM
<i>U_N</i> = 690 V				
ACS880-07-0061A-7	R6	3×25	3×35	4
ACS880-07-0084A-7	R6	3×35	3×50	3
ACS880-07-0098A-7	R7	3×50	3×70	2
ACS880-07-0119A-7	R7	3×70	3×95	1/0
ACS880-07-0142A-7	R8	3×95 3)	3×120	2/0
ACS880-07-0174A-7	R8	3×120 3)	2 × (3×70)	4/0
ACS880-07-0210A-7	R9	3×185	2 × (3×95)	300 MCM

Drive type	Frame size	IEC ¹⁾		US ²⁾
		Cu cable type	Al cable type	Cu cable type
		mm ²	mm ²	AWG/kcmil per phase
ACS880-07-0271A-7	R9	3×240	2 × (3×120)	400 MCM
ACS880-07-0330A-7	R10	2 × (3×120)	3 × (3×120)	2×250 MCM or 3×2/0
ACS880-07-0370A-7	R10	2 × (3×120)	3 × (3×120)	2×300 MCM or 3×3/0
ACS880-07-0425A-7	R11	3 × (3×95)	3 × (3×120)	2×350 MCM or 3×4/0
ACS880-07-0470A-7	R11	3 × (3×95)	3 × (3×150)	2×400 MCM or 3×4/0
ACS880-07-0522A-7	R11	3 × (3×120)	3 × (3×185)	2×500 MCM or 3×250 MCM
ACS880-07-0590A-7	R11	3 × (3×150)	3 × (3×185)	2×600 MCM or 3×300 MCM
ACS880-07-0650A-7	R11	3 × (3×150)	3 × (3×240)	2×700 MCM or 3×350 MCM

1. The cable sizing is based on max. 9 cables laid on a cable ladder side by side, three ladder type trays one on top of the other, ambient temperature 30 °C, PVC insulation, surface temperature 70 °C (EN 60204-1 and IEC 60364-5-52/2001). For other conditions, size the cables according to local safety regulations, appropriate input voltage and the load current of the drive.
2. The cable sizing is based on NEC Table 310-16 for copper wires, 75 °C (167 °F) wire insulation at 40 °C (104 °F) ambient temperature. Not more than three current-carrying conductors in raceway or cable or earth (directly buried). For other conditions, size the cables according to local safety regulations, appropriate input voltage and the load current of the drive.

Alternative power cable types

The recommended and not allowed power cable types to be used with the drive are presented below.

Recommended power cable types

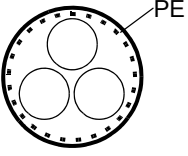
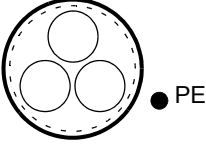
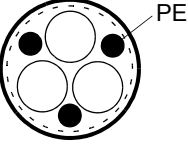
	Symmetrical shielded cable with three phase conductors and a concentric PE conductor as shield. The shield must meet the requirements of IEC 61439-1, see page 78. Check with local / state / country electrical codes for allowance.
	Symmetrical shielded cable with three phase conductors and a concentric PE conductor as shield. A separate PE conductor is required if the shield does not meet the requirements of IEC 61439-1, see page 78.
	Symmetrical shielded cable with three phase conductors and symmetrically constructed PE conductor, and a shield. The PE conductor must meet the requirements of IEC 61439-1.

Power cable types for limited use

	A four-conductor system (three phase conductors and a protective conductor on a cable tray) is not allowed for motor cabling (allowed for input cabling).
---	--

Not allowed power cable types

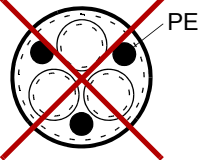
	<p>Symmetrical shielded cable with individual shields for each phase conductor is not allowed on any cable size for input and motor cabling.</p>
---	--

Motor cable shield

If the motor cable shield is used as the sole protective earth conductor of the motor, make sure that the conductivity of the shield is sufficient. See subsection *General rules* above, or IEC 61439-1. To effectively suppress radiated and conducted radio-frequency emissions, the cable shield conductivity must be at least 1/10 of the phase conductor conductivity. The requirements are easily met with a copper or aluminum shield. The minimum requirement of the motor cable shield of the drive is shown below. It consists of a concentric layer of copper wires with an open helix of copper tape or copper wire. The better and tighter the shield, the lower the emission level and bearing currents.

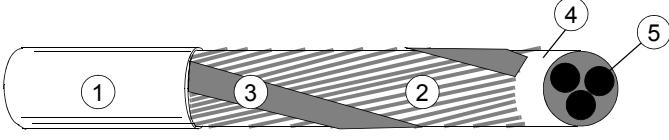
	
1	Insulation jacket
2	Copper wire screen
3	Helix of copper tape or copper wire
4	Inner insulation
5	Cable core

Additional US requirements

Use type MC continuous corrugated aluminum armor cable with symmetrical grounds or shielded power cable for the motor cables if metallic conduit is not used. For the North American market, 600 V AC cable is accepted for up to 500 V AC. 1000 V AC cable is required above 500 V AC (below 600 V AC). For drives rated over 100 amperes, the power cables must be rated for 75 °C (167 °F).

Conduit

Couple separate parts of a conduit together: bridge the joints with a ground conductor bonded to the conduit on each side of the joint. Also bond the conduits to the drive enclosure and motor frame. Use separate conduits for input power, motor, brake resistor, and control wiring. When conduit is employed, type MC continuous corrugated aluminum armor cable or shielded cable is not required. A dedicated ground cable is always required.

Note: Do not run motor wiring from more than one drive in the same conduit.

Armored cable / shielded power cable

The motor cables can be run in the same cable tray as other 460 V or 600 V power wiring. Control and signal cables must not be run in the same tray as power cables.

Six conductor (3 phases and 3 ground) type MC continuous corrugated aluminum armor cable with symmetrical grounds is available from the following suppliers (trade names in parentheses):

- Anixter Wire & Cable (Philsheath)
- BICC General Corp (Philsheath)
- Rockbestos Co. (Gardex)
- Oaknite (CLX).

Shielded power cables are available from Belden, LAPPKABEL (ÖLFLEX) and Pirelli.

Planning the braking system

See chapter [Resistor braking](#).

Selecting the control cables

■ Shielding

All control cables must be shielded.

Use a double-shielded twisted pair cable for analog signals. This type of cable is recommended for the pulse encoder signals also. Employ one individually shielded pair for each signal. Do not use common return for different analog signals.

A double-shielded cable (figure a below) is the best alternative for low-voltage digital signals but single-shielded (b) twisted pair cable is also acceptable.

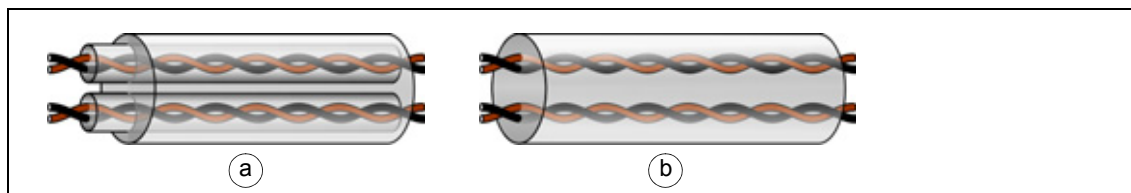

■ Signals in separate cables

Run analog and digital signals in separate, shielded cables. Never mix 24 V DC and 115/230 V AC signals in the same cable.

■ Signals allowed to be run in the same cable

Relay-controlled signals, providing their voltage does not exceed 48 V, can be run in the same cables as digital input signals. The relay-controlled signals should be run as twisted pairs.

■ Relay cable type

The cable type with braided metallic screen (for example ÖLFLEX by LAPPKABEL, Germany) has been tested and approved by ABB.

■ Control panel cable length and type

In remote use, the cable connecting the control panel to the drive must not be longer than three meters (10 ft). Cable type: shielded CAT 5e or better Ethernet patch cable with RJ-45 ends.

Routing the cables

Route the motor cable away from other cable routes. Motor cables of several drives can be run in parallel installed next to each other. The motor cable, input power cable and control cables should be installed on separate trays. Avoid long parallel runs of motor cables with other cables in order to decrease electromagnetic interference caused by the rapid changes in the drive output voltage.

Where control cables must cross power cables, make sure they are arranged at an angle as near to 90 degrees as possible. Do not run extra cables through the drive.

The cable trays must have good electrical bonding to each other and to the grounding electrodes. Aluminum tray systems can be used to improve local equalizing of potential.

A diagram of the cable routing is shown below.

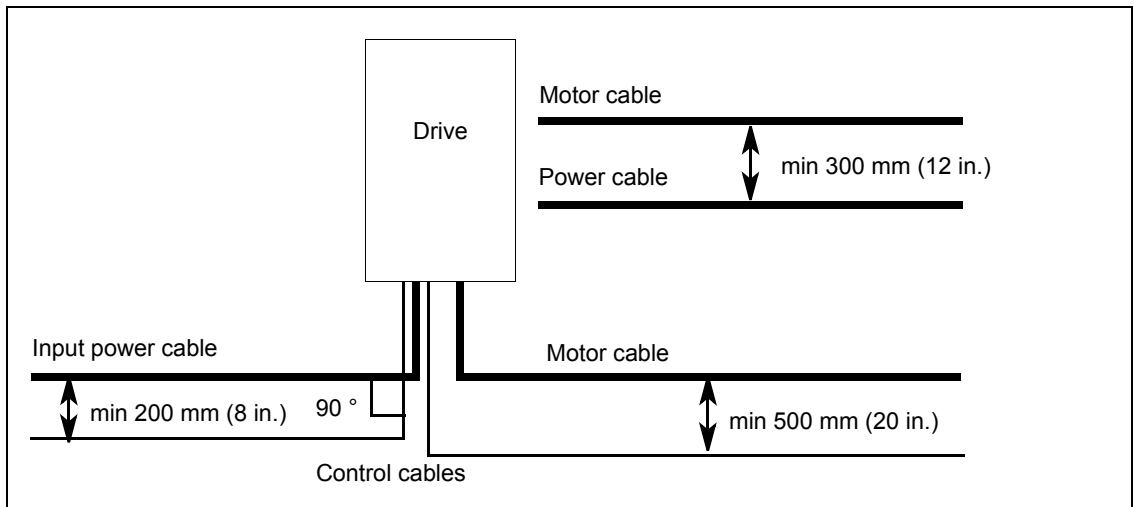

■ Separate control cable ducts

Lead 24 V and 230 V (120 V) control cables in separate ducts unless the 24 V cable is insulated for 230 V (120 V) or insulated with an insulation sleeving for 230 V (120 V).

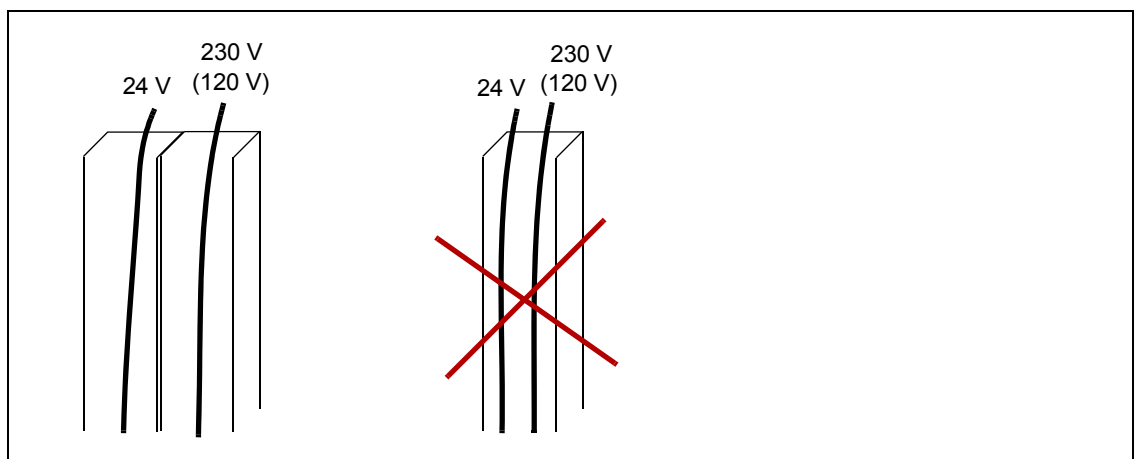

■ Continuous motor cable shield or enclosure for equipment on the

motor cable

To minimize the emission level when safety switches, contactors, connection boxes or similar equipment are installed on the motor cable between the drive and the motor:

- European Union: Install the equipment in a metal enclosure with 360 degree grounding for the shields of both the incoming and outgoing cable, or connect the shields of the cables otherwise together.
- US: Install the equipment in a metal enclosure in a way that the conduit or motor cable shielding runs consistently without breaks from the drive to the motor.

Implementing thermal overload and short-circuit protection

■ Protecting the drive and input power cable in short-circuits

The drive is equipped with internal AC fuses (1) as standard. The fuses restrict drive damage and prevent damage to adjoining equipment in case of a short-circuit inside the drive.

Protect the input cable with fuses or circuit breaker (2) according to local safety regulations, appropriate input voltage and the rated current of the drive (see chapter [Technical data](#)).

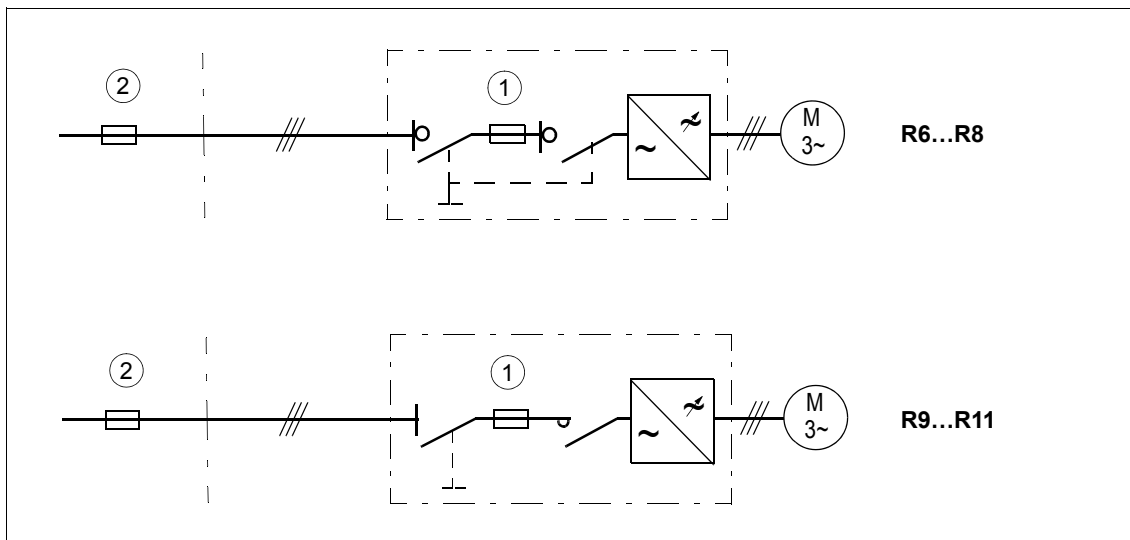

■ Protecting the motor and motor cable in short-circuits

The drive protects the motor cable and motor in a short-circuit situation when the motor cable is sized according to the nominal current of the drive. No additional protection devices are needed.

■ Protecting the drive and the input power and motor cables against thermal overload

The drive protects itself and the input and motor cables against thermal overload when the cables are sized according to the nominal current of the drive. No additional thermal protection devices are needed.



WARNING! If the drive is connected to multiple motors, use a separate circuit breaker or fuses for protecting each motor cable and motor against overload. The drive overload protection is tuned for the total motor load. It may not trip due to an overload in one motor circuit only.

■ Protecting the motor against thermal overload

According to regulations, the motor must be protected against thermal overload and the current must be switched off when overload is detected. The drive includes a motor thermal protection function that protects the motor and switches off the current when necessary. Depending on a drive parameter value, the function either monitors a calculated temperature value (based on a motor thermal model) or an actual temperature indication given by motor temperature sensors. The user can tune the thermal model further by feeding in additional motor and load data.

The most common temperature sensors are:

- motor sizes IEC180...225: thermal switch, eg, Klixon
- motor sizes IEC200...250 and larger: PTC or Pt100.

See the firmware manual for more information on the motor thermal protection, and the connection and use of the temperature sensors.

Protecting the drive against ground faults

The drive is equipped with an internal ground fault protective function to protect the unit against ground faults in the motor and motor cable in TN (grounded) networks. This is not a personnel safety or a fire protection feature. The ground fault protective function can be disabled with a parameter, refer to the firmware manual.

Optional ground fault monitoring device (+Q954) is available for IT (ungrounded) systems. The option includes a ground fault pilot light on the drive cabinet door.

■ Residual current device compatibility

The drive is suitable to be used with residual current devices of Type B.

Note: The EMC filter of the drive includes capacitors connected between the main circuit and the frame. These capacitors and long motor cables increase the ground leakage current and may cause fault current circuit breakers to function.

Implementing the emergency stop function

The drive can be equipped with category 0 and 1 emergency stop function. For safety reasons, install the emergency stop devices at each operator control station and at other operating stations where emergency stop may be needed.

Note: Pressing the stop key  on the control panel of the drive, or turning the operating switch of the drive from position “1” to “0” does not generate an emergency stop of the motor or separate the drive from dangerous potential.

See the appropriate user's manual for the wiring, start-up and operation instructions.

Option code	User's manual	Manual code (English)
+Q951	Emergency stop, stop category 0 (using main contactor/breaker)	3AUA0000119895
+Q952	Emergency stop, stop category 1 (using main contactor/breaker)	3AUA0000119896
+Q963	Emergency stop, stop category 0 (using Safe torque off)	3AUA0000119908
+Q964	Emergency stop, stop category 1 (using Safe torque off)	3AUA0000119909
+Q978	Emergency stop, stop category 0 or 1 (using main contactor/breaker and Safe torque off)	3AUA0000145920
+Q979	Emergency stop, stop category 0 or 1 (using Safe torque off)	3AUA0000145921

Implementing the Safe torque off function

See chapter [Safe torque off function](#) on page 229.

Implementing Prevention of unexpected start-up function

The drive can be equipped with a Prevention of unexpected start-up (POUS) function either with an FSO-xx safety functions module (option +Q950) or with a safety relay (option +Q957). The POUS function enables short-time maintenance work (like cleaning) on the non-electrical parts of the machinery without switching off and disconnecting the drive.

See the appropriate user's manual for the wiring, start-up and operation instructions.

Option code	User's manual	Manual code (English)
+Q950	Prevention of unexpected start-up, with FSO-xx safety functions module	3AUA0000145922
+Q957	Prevention of unexpected start-up, with safety relay	3AUA0000119910

Implementing the functions provided by the FSO-xx safety functions module (option +Q972 or +Q973)

The drive can be equipped with an FSO-xx safety functions module (option +Q972 or +Q973) which enables the implementation of functions such as Safe brake control (SBC), Safe stop 1 (SS1), Safe stop emergency (SSE), Safely limited speed (SLS) and Safe maximum speed (SMS).

The settings of the FSO-xx are at default when delivered from the factory. The connectors of the module are pre-wired to terminal block X68. The wiring of the external safety circuit and configuration of the FSO-xx module are the responsibility of the machine builder.

The FSO-xx reserves the standard Safe torque off (STO) connection of the inverter control unit. STO can still be utilized by other safety circuits through the FSO-xx.

For wiring instructions, safety data and more information on the functions provided by the FSO-xx, refer to its manual.

■ Declaration of Conformity

See page [212](#).

Implementing the Power-loss ride-through function

Implement the power-loss ride-through function as follows:

Check that the power-loss ride-through function of the drive is enabled with parameter **30.31 Undervoltage control** in the ACS880 primary control program.



WARNING! Make sure that the flying restart of the motor will not cause any danger. If you are in doubt, do not implement the Power-loss ride-through function.

■ Units with main contactor (option +F250)

The main contactor of the drive opens in a power-loss situation. When the power returns, the contactor closes. However, if the power-loss situation lasts so long that the drive trips on undervoltage, it must be reset and started again to continue operation. If the power-loss situation lasts so long that the buffering module (C22, see page 29 and 33) empties, the main contactor remains open and the drive operates only after reset and a new start.

With external uninterruptible control voltage (option +G307), the main contactor remains closed in power loss situations. If the power-loss situation lasts so long that the drive trips on undervoltage, it must be reset and started again to continue operation.

Supplying power for the auxiliary circuits

The drive is equipped with an auxiliary control voltage transformer which supplies control voltage, for example, for the control devices and cabinet fan(s).

The following options are to be supplied from external power sources:

- +G300/+G301: Cabinet heaters and/or lighting (230 or 115 V AC; external fuse: 16 A gG)
- +G307: Connection for an external uninterruptible power supply (230 or 115 V AC; external fuse 16 A gG) to the control unit and control devices when the drive is not powered
- +G313: Power supply connection (230 V AC; external fuse 16 A gG) for a motor space heater output.

Using power factor compensation capacitors with the drive

Power factor compensation is not needed with AC drives. However, if a drive is to be connected in a system with compensation capacitors installed, note the following restrictions.



WARNING! Do not connect power factor compensation capacitors or harmonic filters to the motor cables (between the drive and the motor). They are not meant to be used with AC drives and can cause permanent damage to the drive or themselves.

If there are power factor compensation capacitors in parallel with the three phase input of the drive:

1. Do not connect a high-power capacitor to the power line while the drive is connected. The connection will cause voltage transients that may trip or even damage the drive.
2. If capacitor load is increased/decreased step by step when the AC drive is connected to the power line, make sure that the connection steps are low enough not to cause voltage transients that would trip the drive.
3. Check that the power factor compensation unit is suitable for use in systems with AC drives, ie, harmonic generating loads. In such systems, the compensation unit should typically be equipped with a blocking reactor or harmonic filter.

Implementing a safety switch between the drive and the motor

We recommend to install a safety switch between the permanent magnet synchronous motor and the drive output. The switch is needed to isolate the motor during any maintenance work on the drive.

Using a contactor between the drive and the motor

Implementing the control of the output contactor depends on how you select the drive to operate. See also section [Implementing a bypass connection](#) on page 89.

When you have selected to use DTC motor control mode, and motor ramp stop, open the contactor as follows:

1. Give a stop command to the drive.
2. Wait until the drive decelerates the motor to zero speed.
3. Open the contactor.

When you have selected to use DTC motor control mode, and motor coast stop, or scalar control mode, open the contactor as follows:

1. Give a stop command to the drive.
2. Open the contactor.



WARNING! When the DTC motor control mode is in use, never open the output contactor while the drive controls the motor. The DTC motor control operates extremely fast, much faster than it takes for the contactor to open its contacts.

When the contactor starts opening while the drive controls the motor, the DTC control will try to maintain the load current by immediately increasing the drive output voltage to the maximum. This will damage, or even burn the contactor completely.

Implementing a bypass connection

If bypassing is required, employ mechanically or electrically interlocked contactors between the motor and the drive and between the motor and the power line. Make sure with interlocking that the contactors cannot be closed simultaneously.



WARNING! Never connect the drive output to the electrical power network. The connection may damage the drive.

■ Example bypass connection

An example bypass connection is shown below.

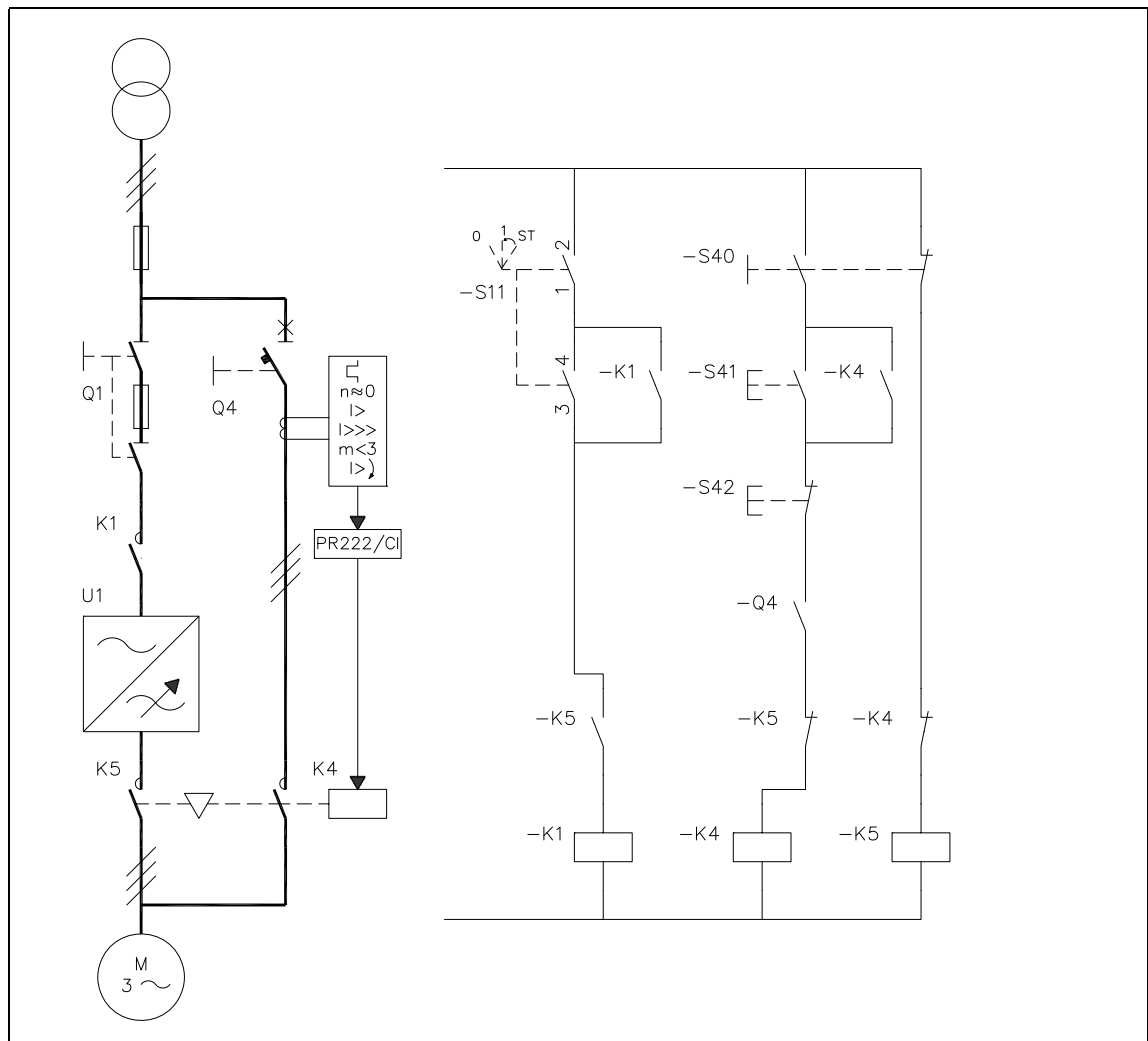

Q1	Drive main switch	S11	Drive main contactor on/off control
Q4	Bypass circuit breaker	S40	Motor power supply selection (drive or direct-on-line)
K1	Drive main contactor	S41	Start when motor is connected direct-on-line
K4	Bypass contactor	S42	Stop when motor is connected direct-on-line
K5	Drive output contactor	-	-

Switching the motor power supply from drive to direct-on-line

1. Stop the drive and the motor with the drive control panel (drive in local control mode) or with the external stop signal (drive in remote control mode).
2. Open the main contactor of the drive with S11.
3. Switch the motor power supply from the drive to direct-on-line with S40.
4. Wait for 10 seconds to allow the motor magnetization to die away.
5. Start the motor with S41.

Switching the motor power supply from direct-on-line to drive

1. Stop the motor with S42.
2. Switch the motor power supply from direct-on-line to the drive with S40.
3. Close the main contactor of the drive with switch S11 (-> turn to position ST for two seconds and leave at position 1).
4. Start the drive and the motor with the drive control panel (drive in local control mode) or with the external start signal (drive in remote control mode).

Protecting the contacts of relay outputs

Inductive loads (relays, contactors, motors) cause voltage transients when switched off.

The relay contacts on the drive control unit are protected with varistors (250 V) against overvoltage peaks. In spite of this, it is highly recommended that inductive loads are equipped with noise attenuating circuits (varistors, RC filters [AC] or diodes [DC]) in order to minimize the EMC emission at switch-off. If not suppressed, the disturbances may connect capacitively or inductively to other conductors in the control cable and form a risk of malfunction in other parts of the system.

Install the protective component as close to the inductive load as possible. Do not install protective components at the relay outputs.

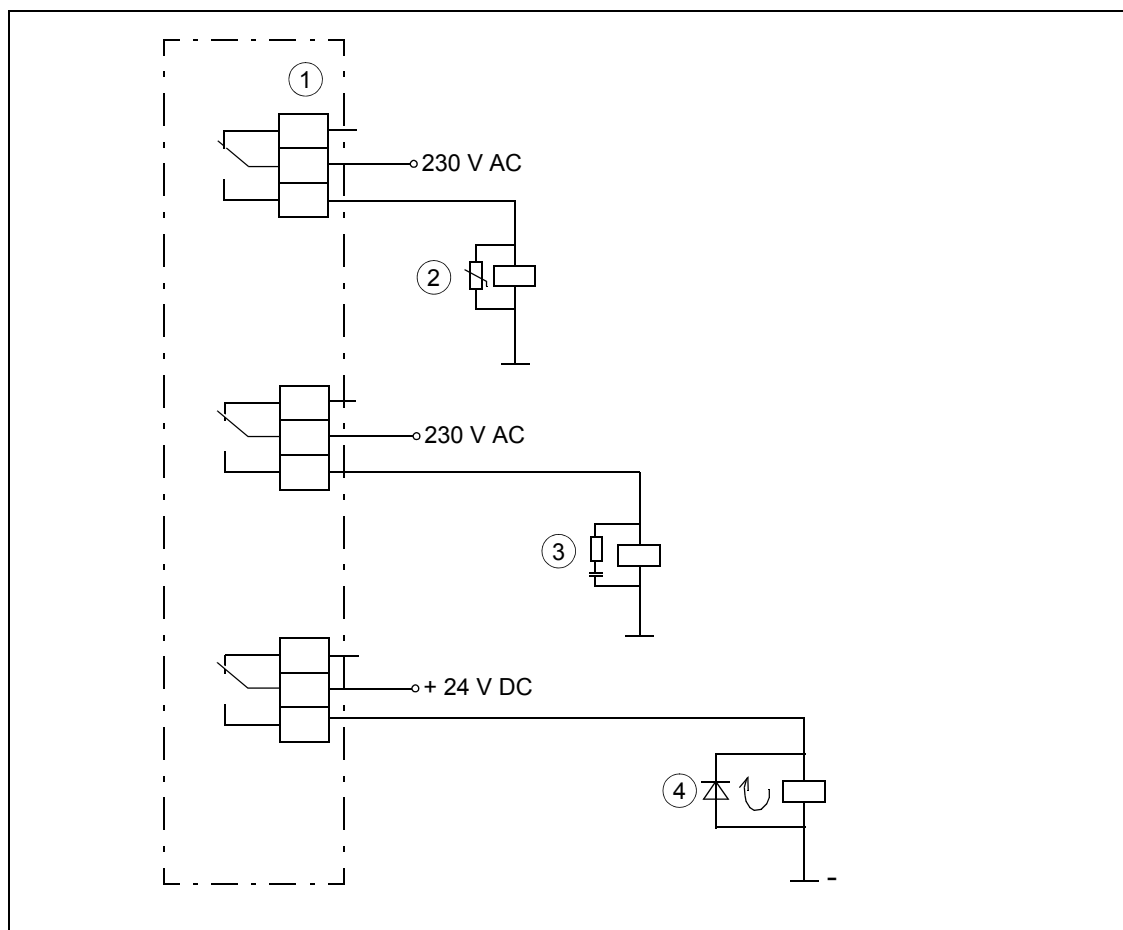

1) Relay outputs; 2) Varistor; 3) RC filter; 4) diode

Connecting a motor temperature sensor to the drive I/O



WARNING! IEC 60664 requires double or reinforced insulation between live parts and the surface of accessible parts of electrical equipment which are either non-conductive or conductive but not connected to the protective earth.

To fulfill this requirement, the connection of a thermistor (and other similar components) to the digital inputs of the drive can be implemented in three alternate ways:

1. There is double or reinforced insulation between the thermistor and live parts of the motor.
2. Circuits connected to all digital and analog inputs of the drive are protected against contact and insulated with basic insulation (the same voltage level as the drive main circuit) from other low voltage circuits.
3. An external thermistor relay is used. The insulation of the relay must be rated for the same voltage level as the main circuit of the drive. For connection, see the firmware manual.

See section [AI1 and AI2 as Pt100, Pt1000, PTC and KTY84 sensor inputs \(XAI, XAO\)](#) on page 129 or section [DI6 \(XDI:6\) as PTC sensor input](#) on page 130.

This table shows what sensor types you can connect to the drive I/O extension and encoder interface modules. These modules require double or reinforced insulation between live parts and the surface of accessible parts of electrical equipment

Option module	Temperature sensor type		
	PTC	KTY	Pt100, Pt1000
FIO-11	-	X	X
FEN-xx	X	-	-
FEN-11, FEN-21, FEN-31	X	X	-
FAIO-01	-	X	X

Note: The inaccuracy of the drive analog inputs for Pt100 sensors is 10 °C (50 °F). If more accuracy is needed, use the FAIO-01 analog I/O extension module (option +L525). It forms double insulation.

6

Electrical installation

Contents of this chapter

This chapter gives instructions on the wiring the drive.

Warnings



WARNING! If you are not a qualified electrician do not do the installation work described in this chapter. Obey the instructions in chapter [Safety instructions](#). If you ignore them, injury or death, or damage to the equipment can occur.



Checking the insulation of the assembly

■ Drive

Do not make any voltage tolerance or insulation resistance tests on any part of the drive as testing can damage the drive. Every drive has been tested for insulation between the main circuit and the chassis at the factory. Also, there are voltage-limiting circuits inside the drive which cut down the testing voltage automatically.

■ Input cable

Check the insulation of the input cable according to local regulations before connecting it to the drive.

Motor and motor cable

1. Check that the motor cable is disconnected from the drive output terminals U2, V2 and W2.
2. Measure the insulation resistance between each phase conductor and then between each phase conductor and the Protective Earth conductor using a measuring voltage of 1000 V DC. The insulation resistance of an ABB motor must exceed 100 Mohm (reference value at 25 °C or 77 °F). For the insulation resistance of other motors, consult the manufacturer's instructions. **Note:** Moisture inside the motor casing will reduce the insulation resistance. If moisture is suspected, dry the motor and repeat the measurement.

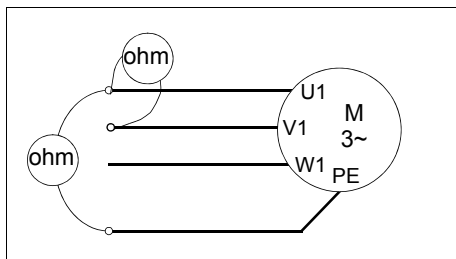

Brake resistor assembly

Check the insulation of the brake resistor assembly (if present) as follows:

1. Check that the resistor cable is connected to the resistor, and disconnected from the drive output terminals R+ and R-.
2. At the drive end, connect the R+ and R- conductors of the resistor cable together. Measure the insulation resistance between the combined conductors and the PE conductor by using a measuring voltage of 1 kV DC. The insulation resistance must be higher than 1 Mohm.

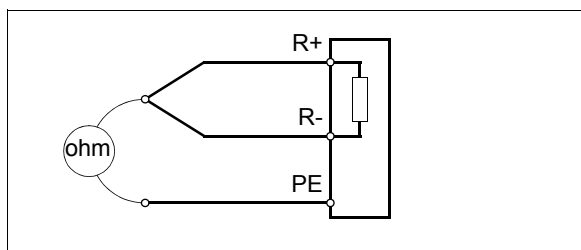

Checking the compatibility with IT (ungrounded) systems

EMC filters +E200 and +E202 are not suitable for use in an IT (ungrounded) system. If the drive is equipped with filter +E200 or +E202, disconnect the filter before connecting the drive to the supply network. For instructions on how to do this, contact your local ABB representative.



WARNING! If a drive with EMC filter +E200 or +E202 is installed on an IT system (an ungrounded power system or a high resistance-grounded [over 30 ohm] power system), the system will be connected to earth potential through the EMC filter capacitors of the drive. This can cause danger, or damage the unit.

Attaching the device stickers on the cabinet door

A multilingual device label sticker is delivered with the drive. Attach the stickers in the local language on the English texts, see section [Door switches and lights](#) on page 42.



Connecting the power cables

■ Connection diagram

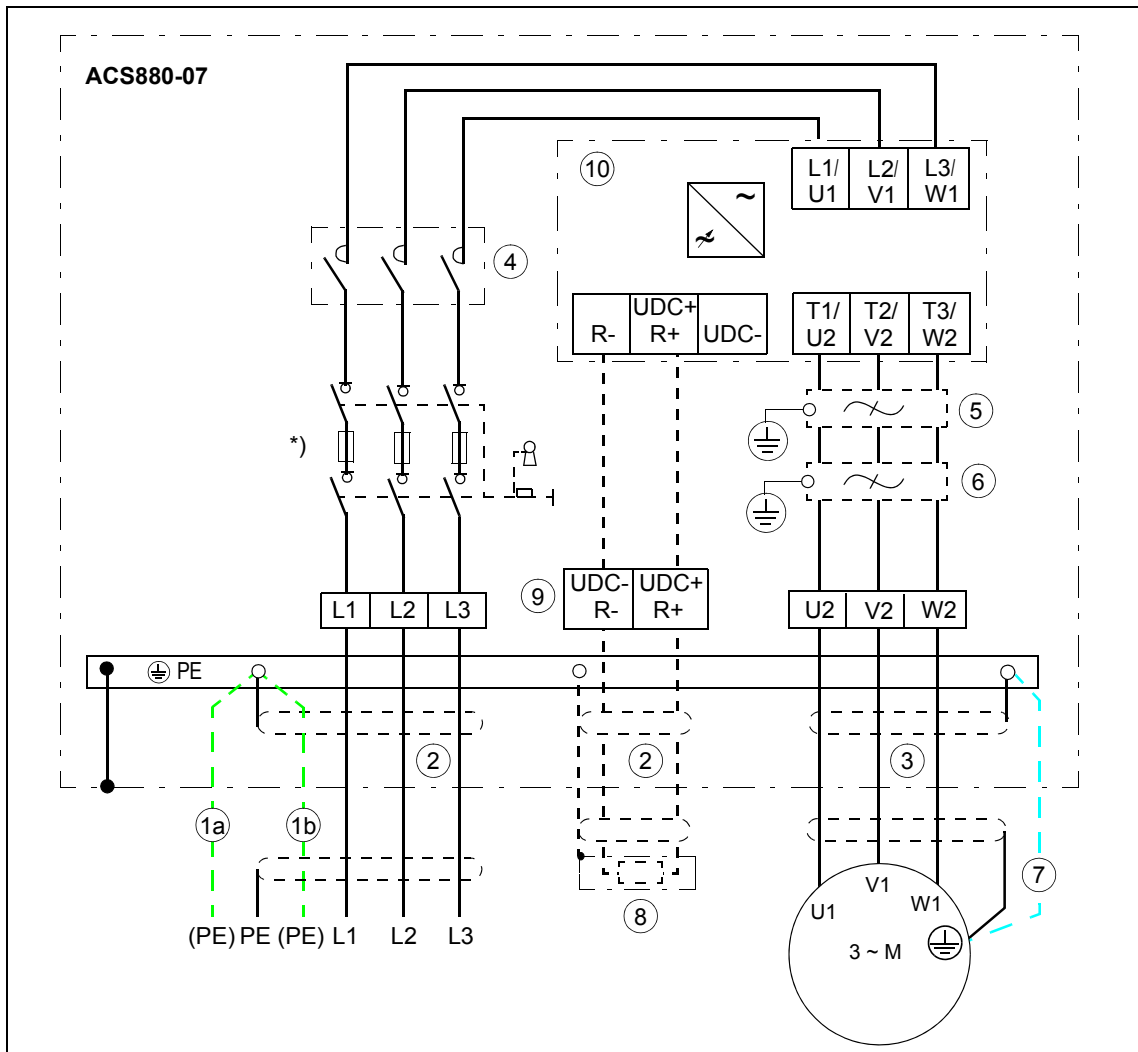

- 1 Use a separate grounding PE cable (1a) or a cable with a separate PE conductor (1b) if the conductivity of the shield does not meet the requirements for the PE conductor (see page 78).
- 2 360-degree grounding is recommended if shielded cable is used. Ground the other end of the input cable shield or PE conductor at the distribution board.
- 3 360-degree grounding is required.
- 4 Line contactor (option +F250)
- 5 Common mode filter (option +E208)
- 6 du/dt filter or sine filter (options +E205 and +E206)
- 7 Use a separate grounding cable if the shield does not meet the requirements of IEC 61439-1 (see page 78) and there is no symmetrically constructed grounding conductor in the cable (see page 80).
- 8 External brake resistor
- 9 Terminals of frame R9 cabinet:

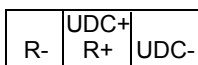

- 10 Drive module

Note:

If there is a symmetrically constructed grounding conductor on the motor cable in addition to the conductive shield, connect the grounding conductor to the grounding terminal at the drive and motor ends.

Do not use an asymmetrically constructed motor cable. Connecting its fourth conductor at the motor end increases bearing currents and causes extra wear.

*) Switch-disconnector and separate fuses in frame R9

■ **Layout of the power cable connection terminals and lead-throughs (frames R6 to R8)**

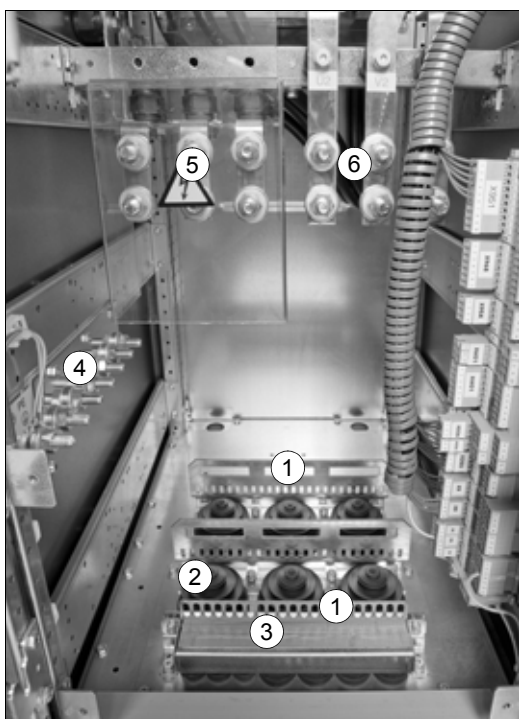

1	Strain relief
2	Power cable lead-throughs. Conductive sleeve under the grommet. The grommets are included in IP54 units only.
3	Control cable lead-through with EMI conductive cushions.
4	PE terminal
5	Input power cable terminals L1, L2 and L3
6	Motor cable terminals U2, V2, W2



■ Layout of the power cable connection terminals and lead-throughs (frames R6 to R8 with option +C129)

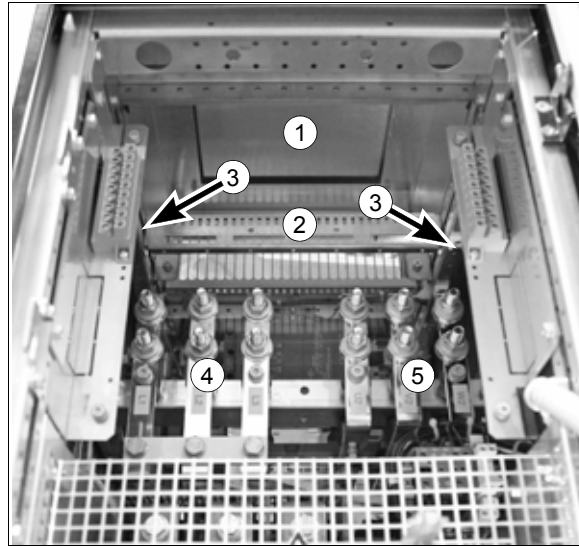

1	Power cable lead-throughs
2	Strain relief
3	Ground bar
4	Input cable power connection terminals L1, L2 and L3
5	Motor cable connection terminals U2, V2, W2



■ **Layout of the power cable connection terminals and lead-throughs (frames R6 to R8 with options +C129+F277+F289)**

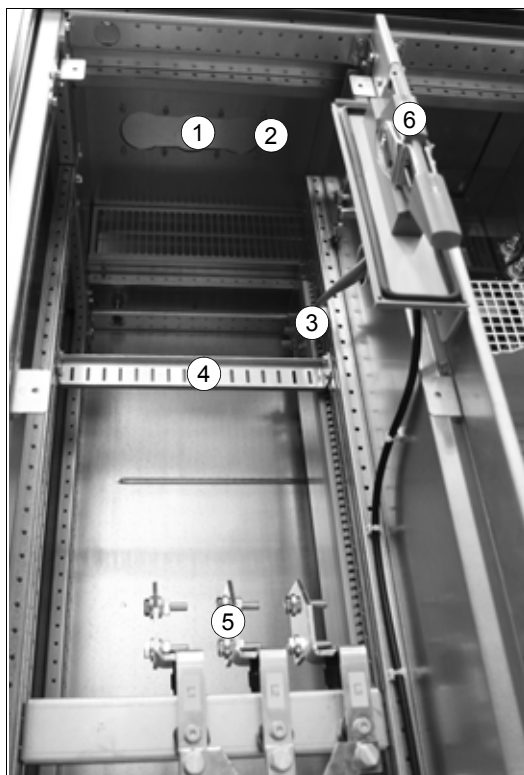

1	Input power cable lead-through
2	Control cable lead-through
3	Ground bar for input power cables
4	Strain relief
5	Input cable power connection terminals L1, L2
6	Flange mounted switch for molded case circuit breaker (+F277)

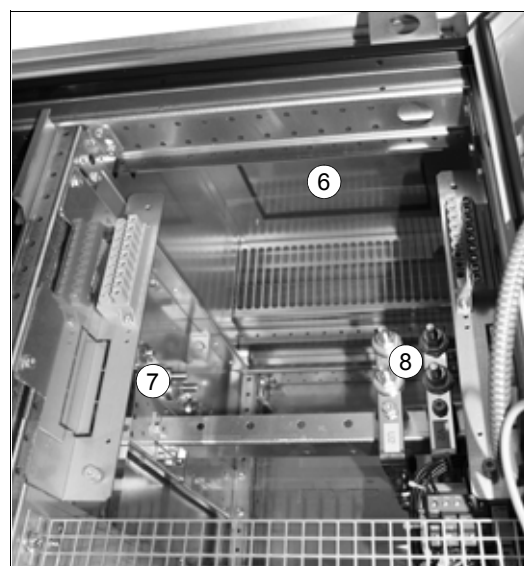

6	Motor cable lead-through
7	Ground bar for motor cables
8	Motor cable connection terminals U2, V2, W2



■ **Layout of the input and motor cable connection terminals (frame R9)**

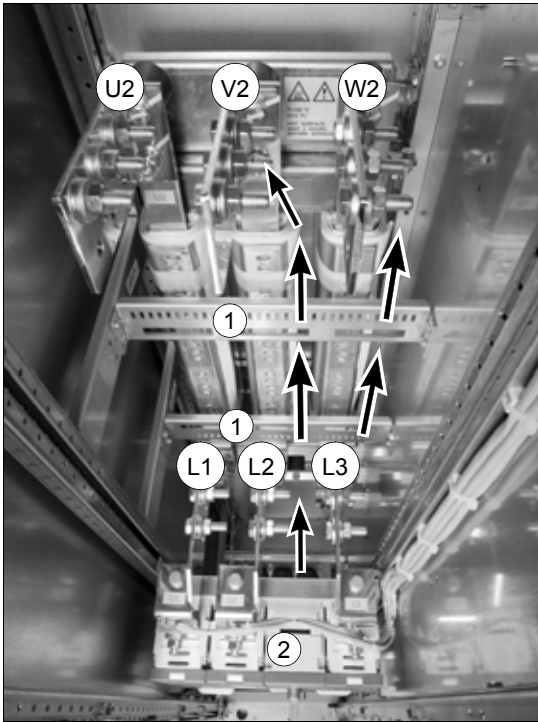

1	Strain relief
L1, L2, L3	Input power cable terminals
U2, V2, W2	Motor cable terminals
2	Main switch-disconnector

Cable routing from below is shown with the arrows.



■ **Layout of the power cable connection terminals and lead-throughs (frame R9 with option +C129)**



1	Power cable lead-through
2	Strain relief
3	Ground bar
4	Input cable power connection terminals L1, L2 and L3
5	Motor cable connection terminals U2, V2, W2



■ **Layout of the input and motor cable connection terminals (frames R10 and R11)**

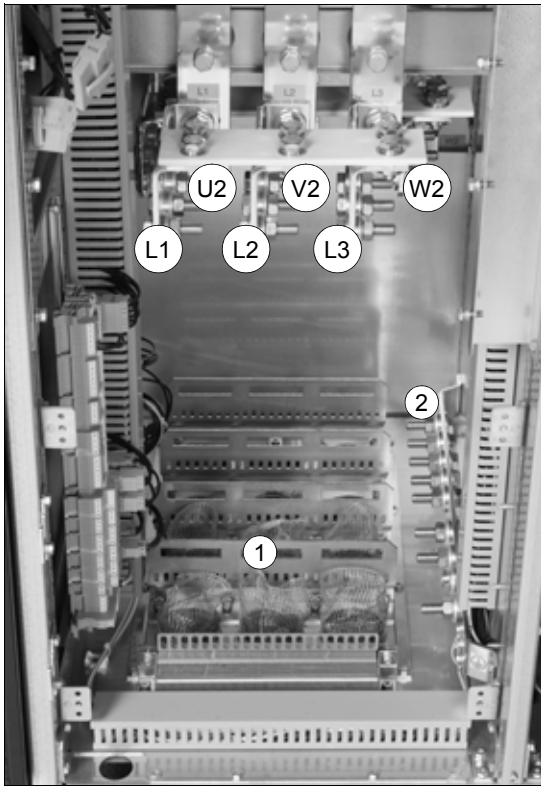

1	Strain relief
L1, L2, L3	Input power cable terminals
U2, V2, W2	Motor cable terminals
2	PE terminal

■ **Layout of the input and motor cable connection terminals (frames R10 and R11 with option +C129)**

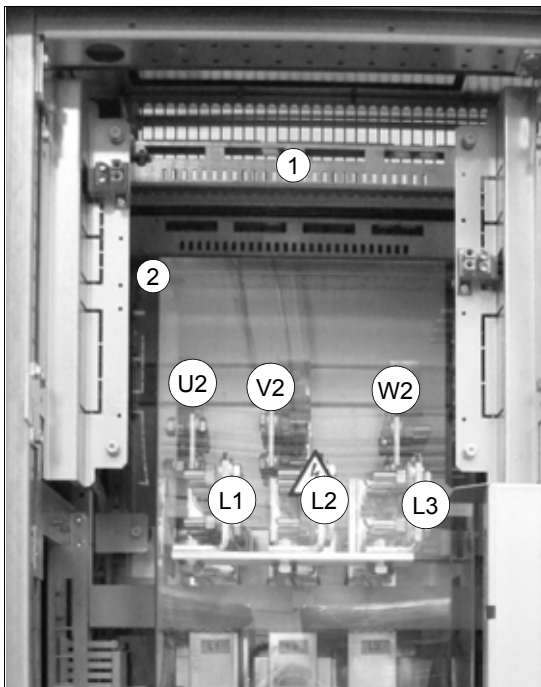

1	Strain relief
L1, L2, L3	Input power cable terminals
U2, V2, W2	Motor cable terminals
2	PE terminal

■ Lead-through of external resistor and DC cables

Run the external brake resistor cables and DC cables into the drive cabinet through the power cable lead-throughs at the base of the drive module cubicle. In frames R6 to R8 the connection terminals are in the drive module. In frame R9, the connection terminals are located below the drive module.

■ Connection procedure (IEC)

1. Do the steps in section *Precautions before electrical work* on page 16 before you start the work.
2. Open the cabinet door.
3. Open the swing-out frame.
4. For frames R6 to R11: Remove the mounting plate(s) above the cabinet “door” fan by undoing the mounting screws. With options +G300, +G307, +G313: Unplug the connectors at the back of the mounting plate.
5. Remove the fan mounting plate by loosening the mounting screws and lifting it up. Unplug the fan supply cables.
6. For frames R9 to R11: Remove the shrouds on the power cable terminals.
7. Peel off 3 to 5 cm of the outer insulation of the cables above the lead-through plate for the 360° high-frequency grounding.
8. Prepare the ends of the cables.



WARNING! Apply grease to stripped aluminum conductors before attaching them to non-coated aluminum cable lugs. Obey the grease manufacturer’s instructions. Aluminum-aluminum contact can cause oxidation in the contact surfaces.

9. If fire insulation is used, make an opening in the mineral wool sheet according to the diameter of the cable.
10. For IP22, IP42 drives: Slide the cables through the lead-throughs with the conductive sleeves.
11. For IP54 drives: Remove rubber grommets from the lead-through plate for the cables to be connected. Cut adequate holes into the rubber grommets. Slide the grommets onto the cables. Slide the cables through the lead-throughs with the conductive sleeves and attach the grommets to the holes.
12. Fasten the conductive sleeves to the cable shields with cable ties.
13. Seal the slot between the cable and mineral wool sheet (if used) with sealing compound (eg, CSD-F, ABB brand name DXXT-11, code 35080082).
14. Tie up the unused conductive sleeves with cable ties.
15. Connect the twisted shields of the motor cables to the ground bar and the phase conductors to the U2, V2 and W2 terminals.
16. For drives with external brake resistors (option +D150 and no +D151): Connect the twisted shields of the resistor cables (if present) to the ground bar and the conductors to the R- and R+ terminals.



17. Connect the twisted shields of the input cables and separate ground cable (if present) to the PE terminal of the cabinet and the phase conductors to the L1, L2 and L3 terminals.
18. Tighten the power cable screws to the torque given in [Terminal and lead-through data for the power cables](#) on page 198.
19. Reinstall the shroud(s) and mounting plates.



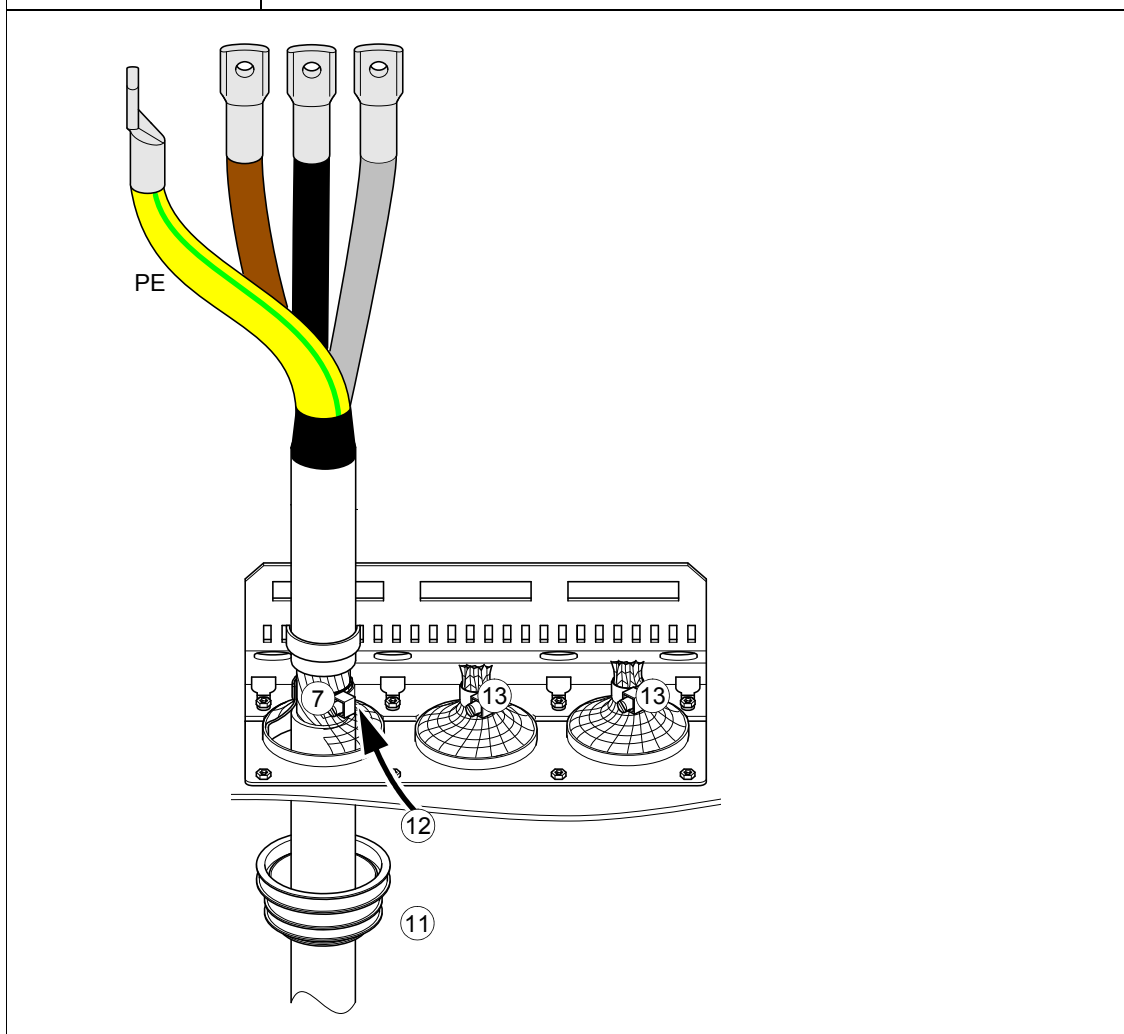
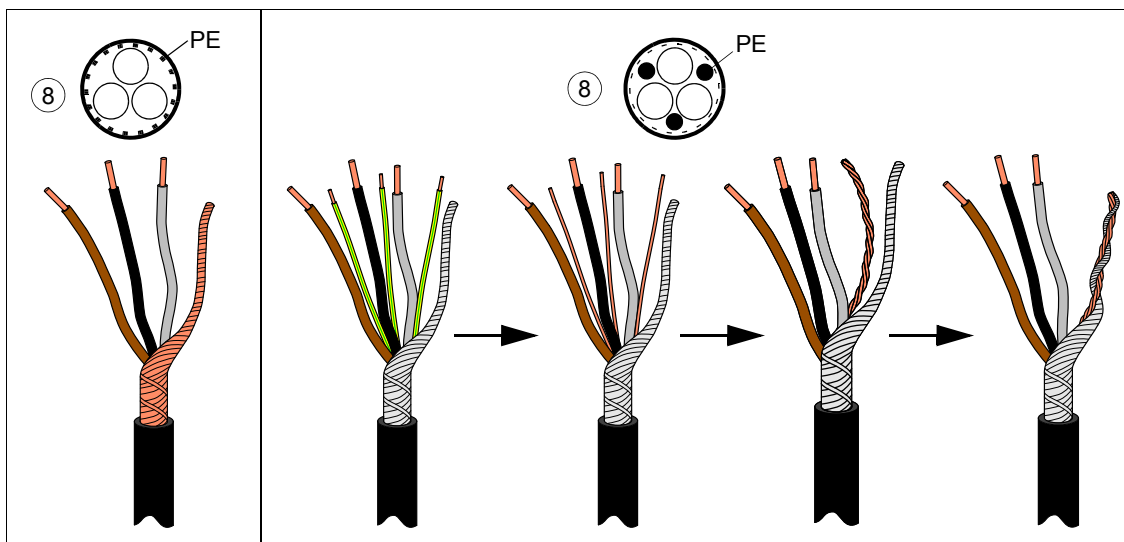

■ Connection procedure (US)



WARNING! Apply grease to stripped aluminum conductors before attaching them to non-coated aluminum cable lugs. Obey the grease manufacturer's instructions. Aluminum-aluminum contact can cause oxidation in the contact surfaces.

1. Do the steps in section *Precautions before electrical work* on page 16 before you start the work.
2. Open the cabinet door.
3. Open the swing-out frame (if installed).
4. Plan cable access and mark the conduit plate accordingly for the input and output power and control cables.
5. Remove the conduit plate from the drive cabinet and cut holes as needed for the conduit connections. **Note:** Never cut metal in or around an equipment cabinet. Metal debris can cause damage to electrical equipment and hazardous conditions.
6. Reinstall the conduit plate to cabinet and connect all electrical conduits as needed to conduit plate. Do not leave any open holes at the top of the cabinet.
7. Run the motor power cables and separate ground cable (if present) from the motor to cabinet.
8. Connect the motor power cable shields and separate ground cable (if present) to the ground bar at the top of the cabinet.
9. Connect the motor phase conductors to the output power terminals U2, V2 and W2.
10. For drives with external brake resistors (option +D150 and no +D151):
 - Run the power cables from the brake resistor to the cabinet including the proper grounding cable.
 - Connect the ground cable to the ground bar at top of cabinet.
 - Connect the brake resistor power cables to the R- and R+ terminals.
11. Make sure that all power is disconnected and reconnection is not possible. Use proper safe disconnect procedures according to local codes.
12. Run the AC power supply cables and separate ground cables (if present) from the supply source to the cabinet.
13. Connect AC power supply cable shields and separate ground cables (if present) to the ground bar at top of cabinet.
14. Connect AC supply phase conductors to terminals L1, L2 and L3.
15. Reinstall the shroud(s) and mounting plates.



■ Grounding the motor cable shield at the motor end

Always ground the motor cable shield at the motor end. For minimum radio frequency interference, ground the motor cable shield 360 degrees at the lead-through of the motor terminal box

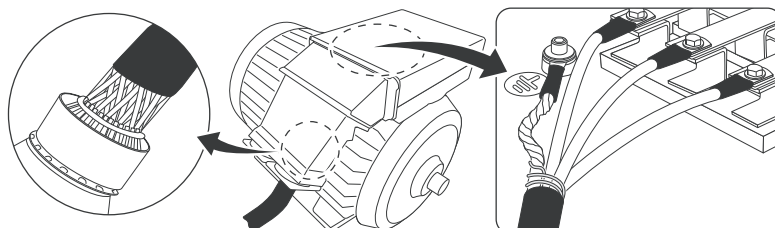

See also [Continuous motor cable shield or enclosure for equipment on the motor cable](#) on page 83.

■ DC connection (option +H356)

The UDC+ and UDC- terminals are intended for common DC configurations of a number of drives, allowing regenerative energy from one drive to be utilized by the other drives in motoring mode. Contact your local ABB representative for further instructions.

Connecting the control cables

See chapter [Control unit of frames R6 to R9](#) on page 125 or [Control unit of frames R10 and R11](#) on page 135 for the default I/O connections of ACS880 primary control program. The default I/O connections can be different with some hardware options, see the circuit diagrams delivered with the drive for the actual wiring. For other control programs, see their firmware manuals.

Connect the cables as described under [Control cable connection procedure](#) on page 107.

■ Control cable connection procedure



WARNING! Obey the instructions in chapter [Safety instructions](#). If you ignore them, injury or death, or damage to the equipment can occur.

1. Stop the drive and do the steps in section [Precautions before electrical work](#) on page 16 before you start the work.
2. Frames R6 to R9: Remove the cabinet fan and mounting plate above it as described under section [Connecting the power cables](#) on page 96.
3. Run the control cables to the inside of the drive module cubicle as described in section [Grounding the outer shields of the control cables at the cabinet lead-through](#) below.
4. Route the control cables as described in section [Routing the control cables inside the cabinet \(frames R6 to R8\)](#) on page 110 or [Routing the control cables inside the cabinet \(frame R9\)](#) on page 111 or [Routing the control cables inside the cabinet \(frames R10 and R11\)](#) on page 112.
5. Connect the control cables as described in sections [Connecting the control unit cables](#) on page 112 ... [Wiring ground fault monitoring for IT ungrounded systems \(option +Q954\)](#) on page 118.



Grounding the outer shields of the control cables at the cabinet lead-through

Applicability

This section applies to drives without solid cable conduit plate (no options +C129, +H351, +H353, +H358).

Procedure

Ground the outer shields of all control cables 360 degrees at the EMI conductive cushions as follows:

1. Loosen the tightening screws of the EMI conductive cushions and pull the cushions apart.
2. Cut adequate holes to the rubber grommets in the lead-through plate and lead the cables through the grommets and the cushions into the cabinet.
3. Strip off the cable plastic sheath above the lead-through plate just enough to ensure proper connection of the bare shield and the EMI conductive cushions.
4. Tighten the two tightening screws so that the EMI conductive cushions press tightly round the bare shield.

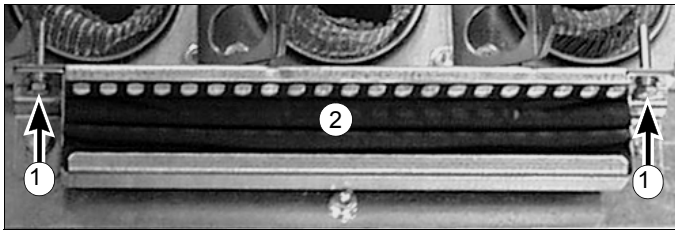

View from above

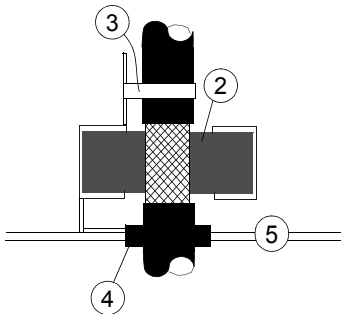

- 1 Tightening screw
- 2 EMI conductive cushion
- 3 Strain relief
- 4 Grommet
- 5 Lead-through plate

Note 1: Keep the shields continuous as close to the connection terminals as possible. Secure the cables mechanically at the lead-through strain relief.

Note 2: If the outer surface of the shield is non-conductive:

- Cut the shield at the midpoint of the bare part. Be careful not to cut the conductors or the grounding wire (if present).
- Turn the shield inside out to expose its conductive surface.
- Cover the turned shield and the stripped cable with copper foil to keep the shielding continuous.

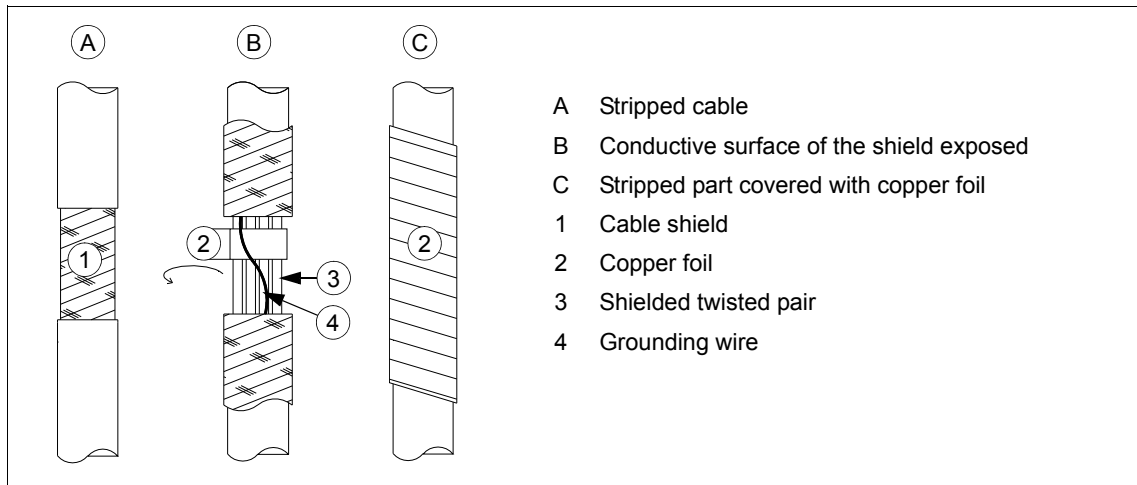

Note for top entry of cables: When each cable has its own rubber grommet, sufficient IP and EMC protection can be achieved. However, if very many control cables come to one cabinet, plan the installation beforehand as follows:

1. Make a list of the cables coming to the cabinet.
2. Sort the cables going to the left into one group and the cables going to the right into another group to avoid unnecessary crossing of cables inside the cabinet.
3. Sort the cables in each group according to size.
4. Group the cables for each grommet as follows ensuring that each cable has a proper contact to the cushions on both sides.

Cable diameter in mm	Max. number of cables per grommet
≤ 13	4
≤ 17	3
< 25	2
≥ 25	1

5. Divide the bunches so that cables will be arranged according to size from thickest to the thinnest between the EMI conductive cushions.
6. If more than one cable go through a grommet, seal the grommet by applying Loctite 5221 (catalogue number 25551) inside the grommet.

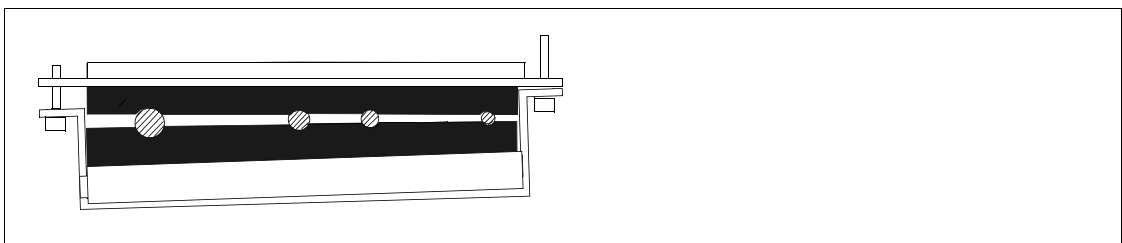

Routing the control cables inside the cabinet (frames R6 to R8)

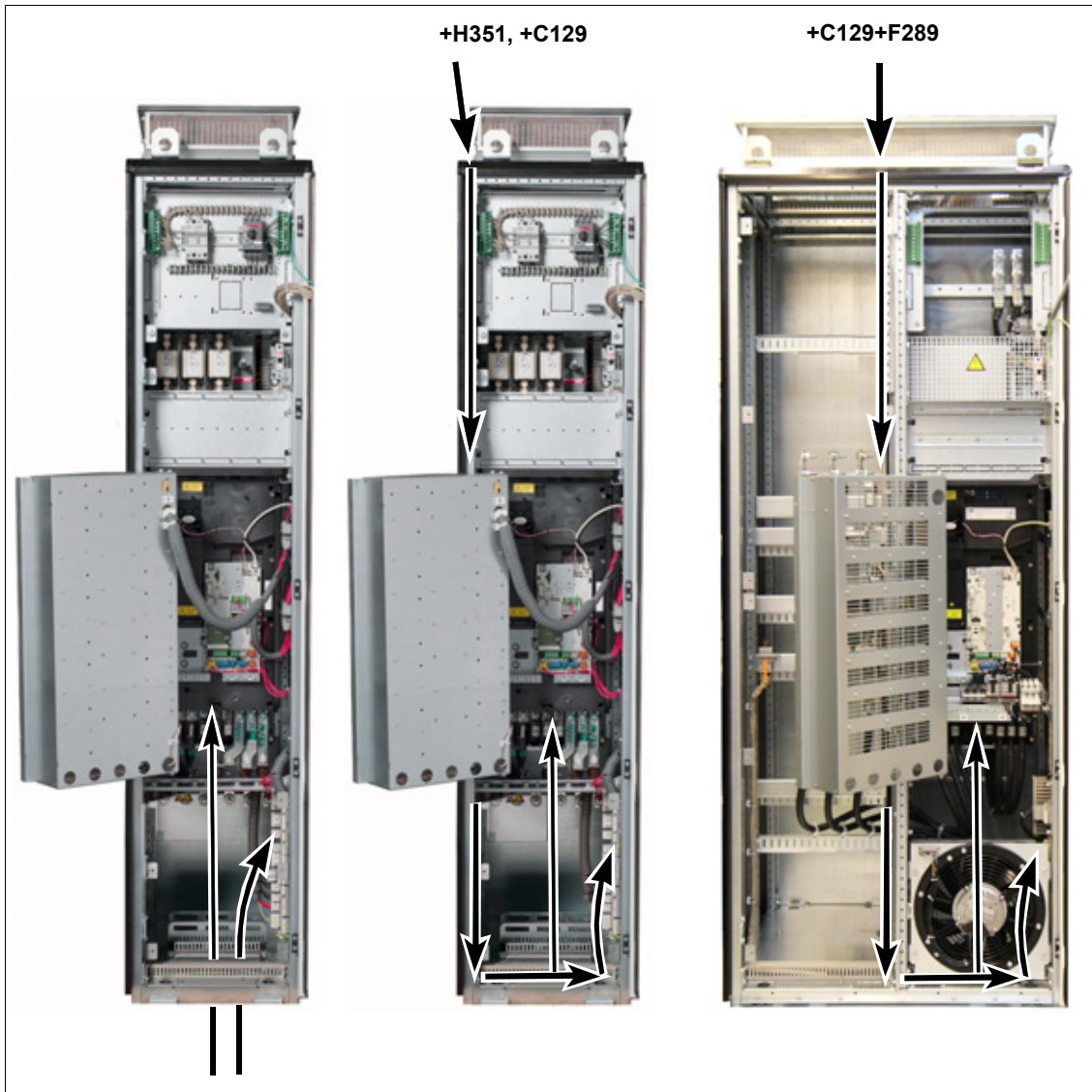

Routing the control cables inside the cabinet (frame R9)



Routing the control cables inside the cabinet (frames R10 and R11)



Note: Leave some slack in the control wiring to allow the removing of the control unit assembly plate when the drive module is replaced.

Connecting the control unit cables

Note: Keep any signal wire pairs twisted as close to the terminals as possible. Twisting the wire with its return wire reduces disturbances caused by inductive coupling.

Note for frames R10 and R11: Leave slack to the control wires to make it possible to lift the control unit mounting plate a little when the drive module is replaced.

Units without additional I/O terminal block (option L504): Ground the pair-cable shields and all grounding wires to the clamp below the control unit as shown below.

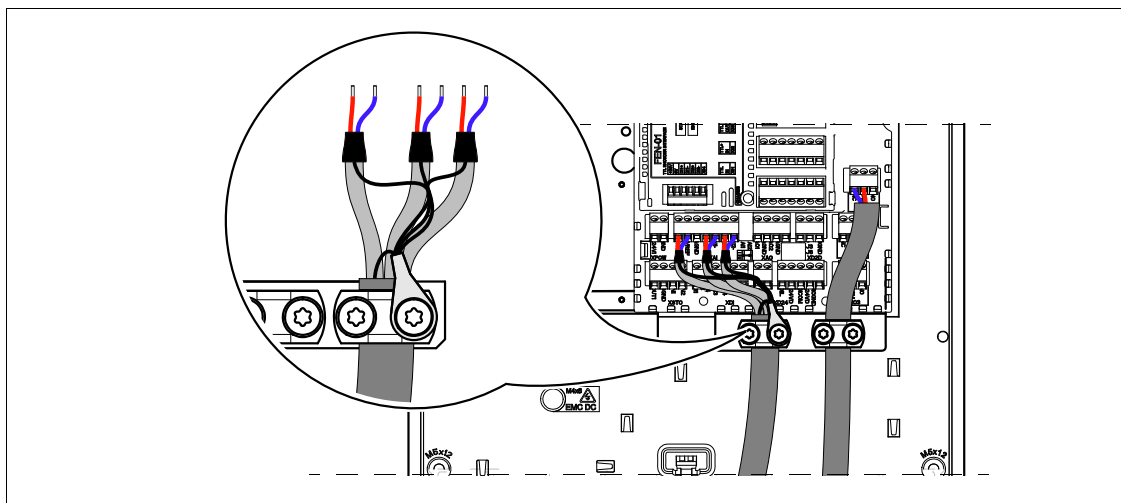

Units with additional I/O terminal block (option L504): Ground the pair-cable shields and all grounding wires to the grounding clamp below the terminal block as shown below.

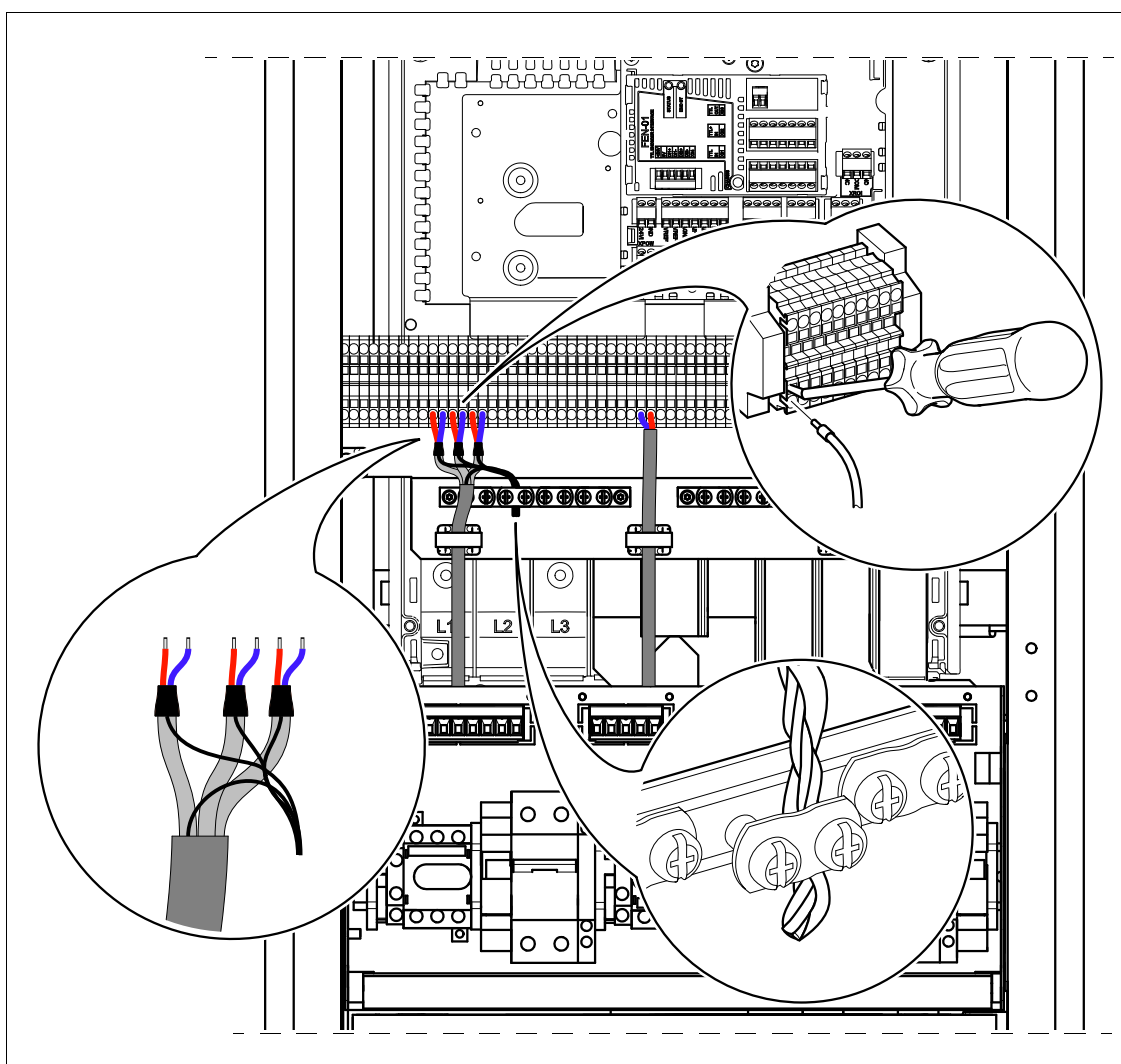

Leave the other ends of the control cable shields unconnected or ground them indirectly via a high-frequency capacitor with a few nanofarads, eg, 3.3 nF / 630 V. The shield can also be grounded directly at both ends if they are in the same ground line with no significant voltage drop between the end points.

Connect the conductors to the appropriate terminals (see page 127 or 137) of the control unit or optional terminal block X504.

Connecting the external 230 V or 115 V uninterruptible control voltage (UPS, option +G307)

Wire the external control voltage to terminal block X307 at the back side of the mounting plate as shown below.

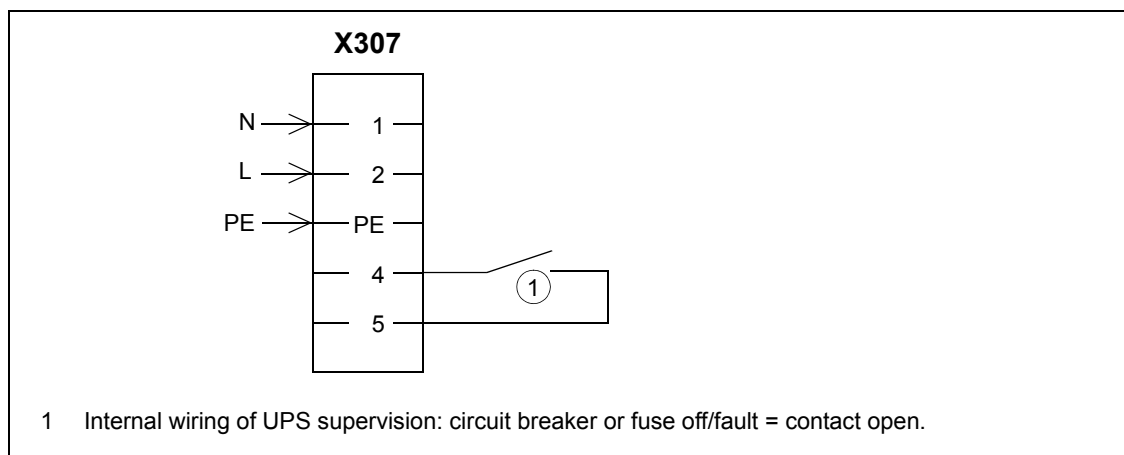

Connecting the emergency stop push buttons (options +Q951, +Q952, +Q963, +Q964)

Connect the emergency stop push buttons to terminals according to the circuit diagrams delivered with the drive.



Wiring the starter for auxiliary motor fan (options +M600...+M605)

Connect the power supply wires for the auxiliary motor fan to terminals X601...X605 according to the circuit diagrams delivered with the drive.

Wiring the thermistor relay(s) (options +L505 and +2L505)

The external wiring of option +2L505 (two thermistor relays) is shown below. For example, one relay can be used to monitor the motor windings, the other to monitor the bearings. The maximum contact load capacity is 250 V AC 10 A. For the actual wiring, see the circuit diagram delivered with the drive.

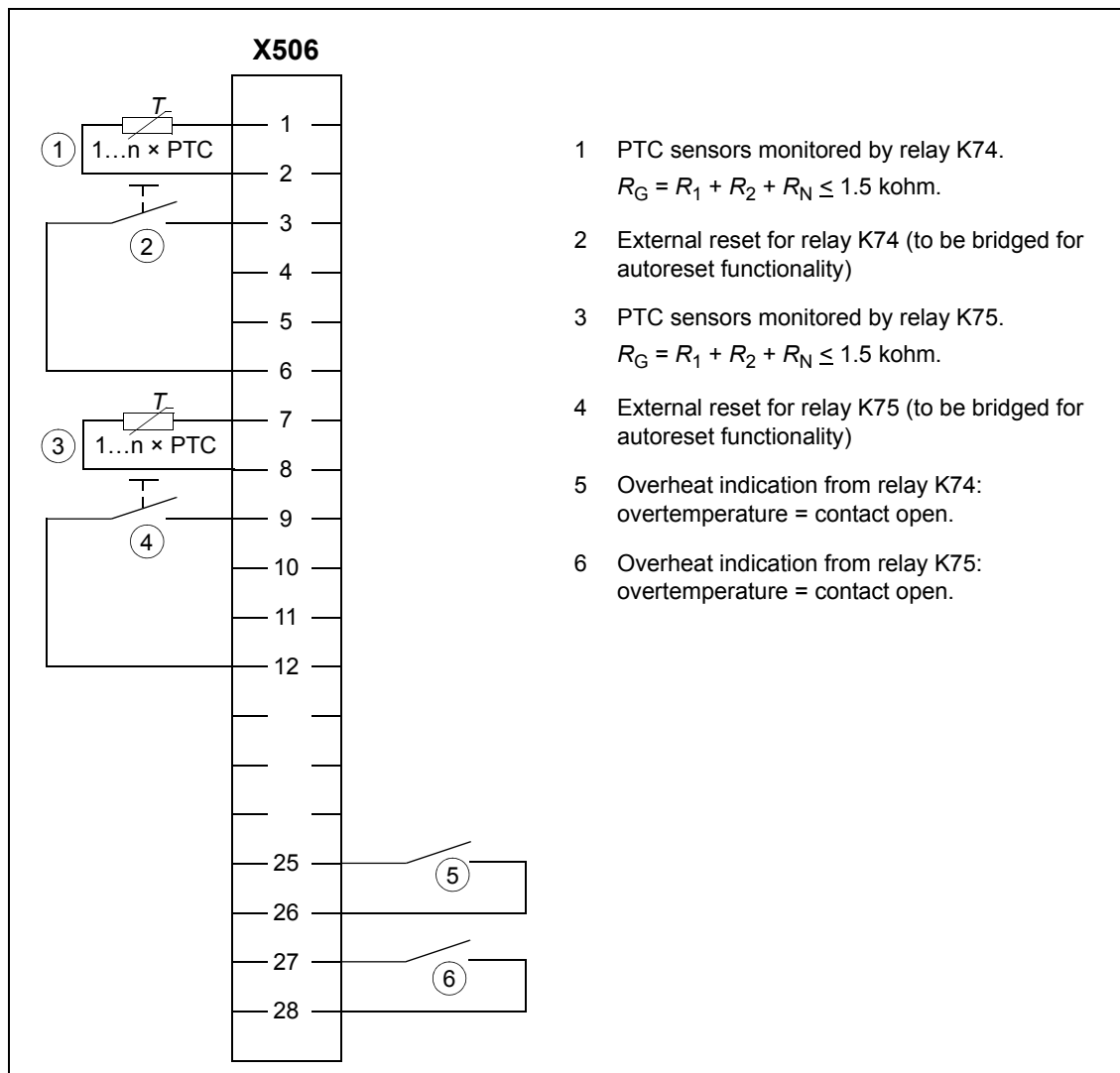

Wiring the Pt100 relays (options +2L506, +3L506, +5L506 and +8L506)

External wiring of eight Pt100 sensor modules is shown below. Contact load capacity 250 V AC 10 A. For the actual wiring, see the circuit diagram delivered with the drive.

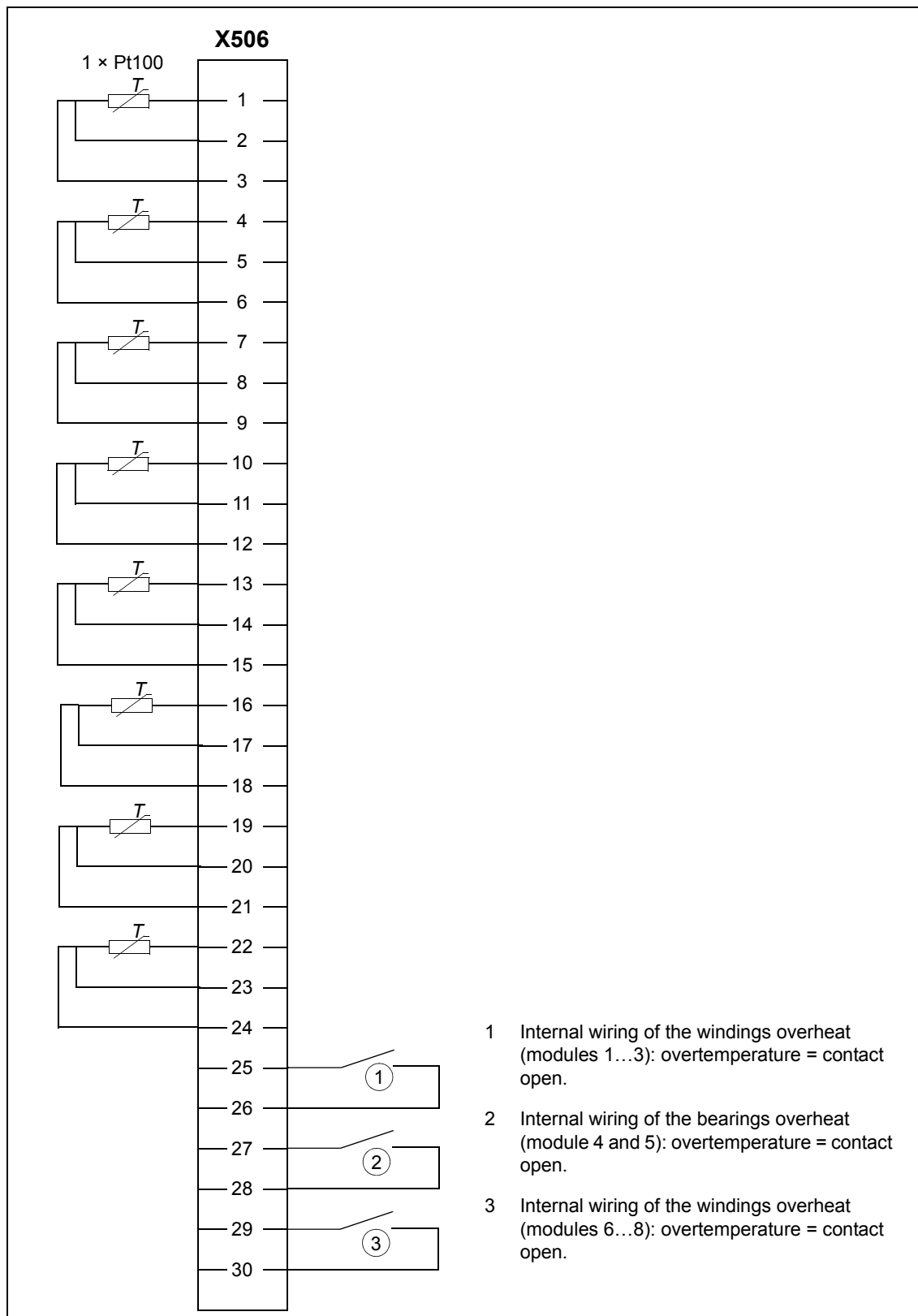

Connecting the external power supply cables for the cabinet heater and lighting and motor heater (options +G300, +G301 and +G313)

See the circuit diagrams delivered with drive.

Connect the external power supply wires for the cabinet heater and lighting to terminal block X300 at the back of the mounting plate.

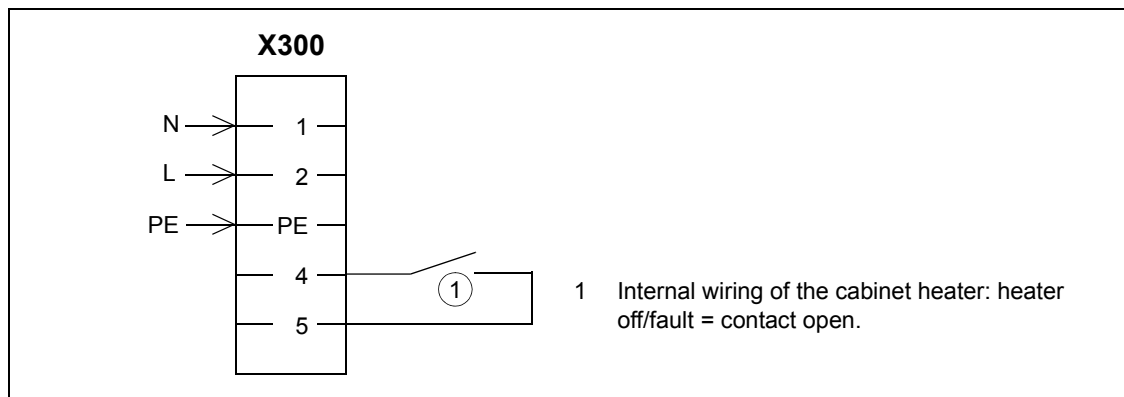

Connect the motor heater wiring to terminal block X313 as shown below. Maximum external power supply 16 A.

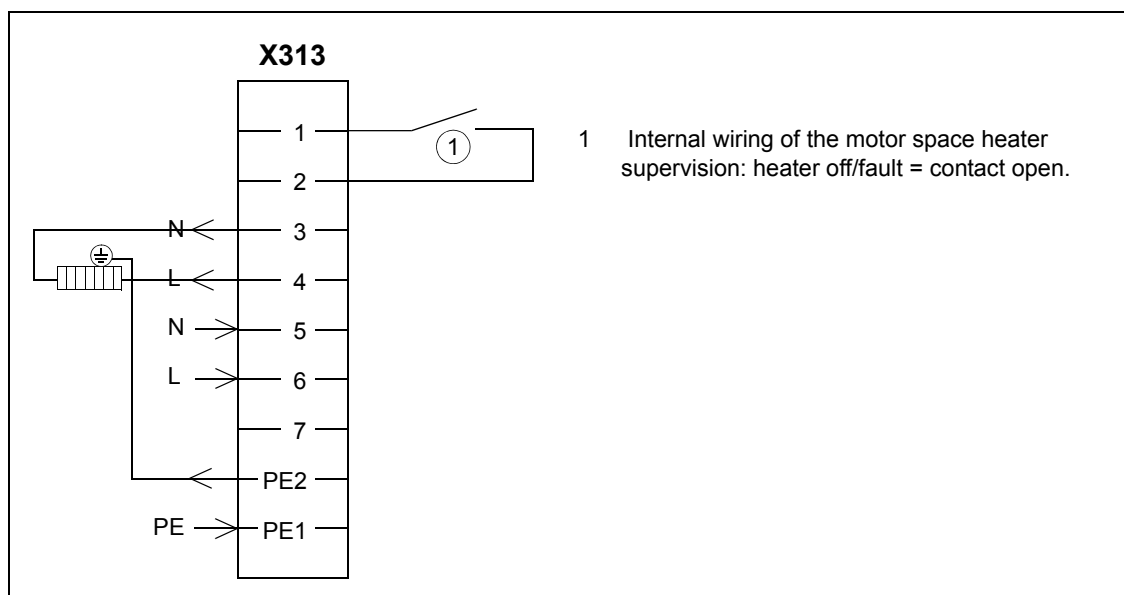

Wiring ground fault monitoring for IT ungrounded systems (option +Q954)

We recommend to connect Alarm 1 for drive tripping and Alarm 2 for alarm signals in order to avoid unnecessary trippings due to the ground fault monitor self testing with Alarm 2.

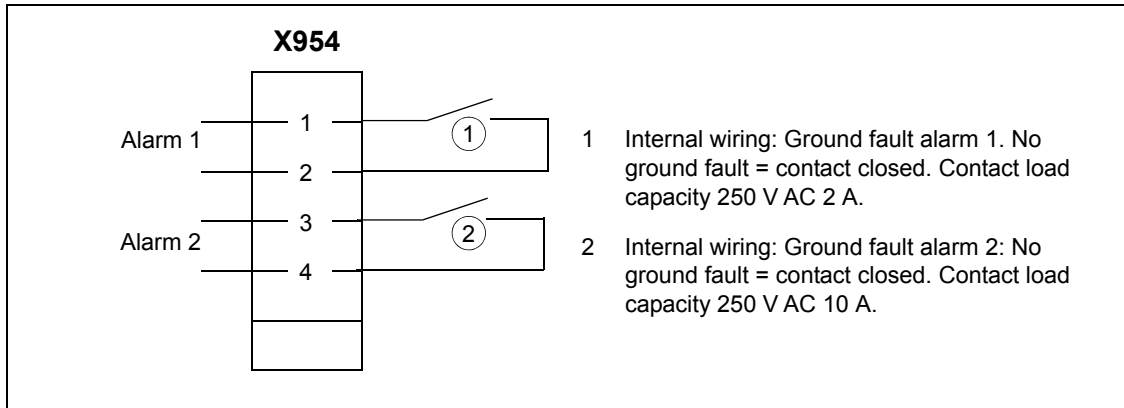

Setting the voltage range of the auxiliary control voltage transformer (T21)

Connect the power supply wires of the auxiliary control voltage transformer according to the power network voltage.

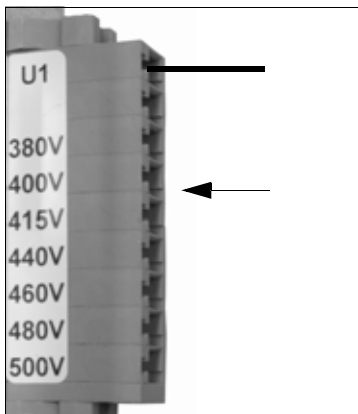

Connecting a PC

A PC (with eg. the Drive composer PC tool) can be connected to the idrive as follows:

1. Connect an ACS-AP-I control panel to the drive either by using an Ethernet (eg. CAT5E) networking cable, or by inserting the panel into the panel holder.



WARNING! Do not connect the PC directly to the control panel connector of the control unit as this can cause damage.

2. Lift the USB connector cover on the control panel from bottom upwards.
3. Connect an USB cable (Type A to Type Mini-B) between the USB connector on the control panel (3a) and a free USB port on the PC (3b).
4. The panel displays an indication whenever the connection is active

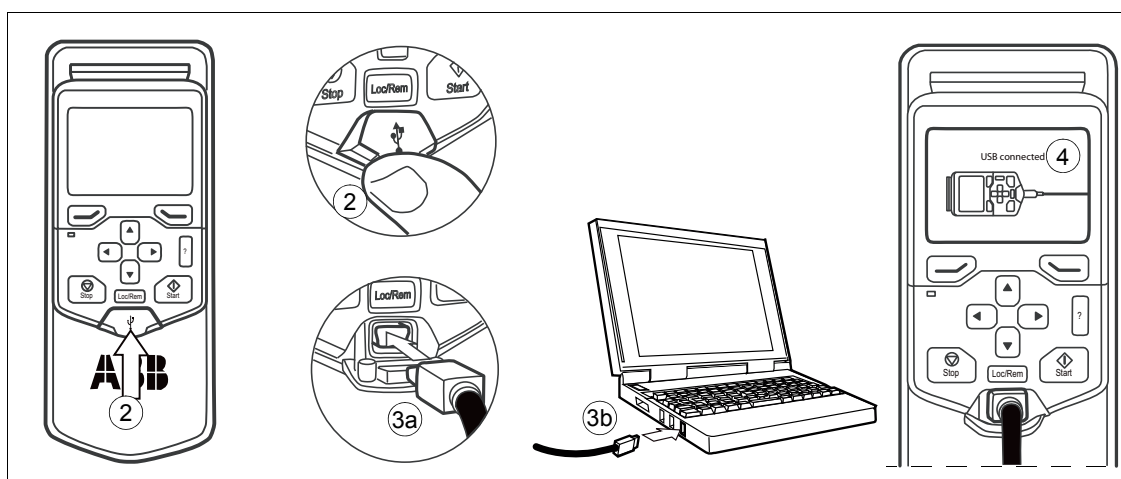

Note 1: When a PC is connected to the control panel, the control panel keypad is disabled. In this case, the control panel acts as a USB-RS485 adapter.



Installing option modules

■ Mechanical installation of I/O extension, fieldbus adapter and pulse encoder interface modules

See page 40 for the available slots for each module. Install the option modules as follows:



WARNING! Obey the instructions in chapter [Safety instructions](#). If you ignore them, injury or death, or damage to the equipment can occur.

1. Stop the drive and do the steps in section [Precautions before electrical work](#) on page 16 before you start the work.
2. Frames R6 to R9: Open the swing-out frame.
3. Insert the module carefully into its position on the control unit.
4. Tighten the mounting screw torque of 0.8 N·m. **Note:** The screw tightens the connections and grounds the module. It is essential for fulfilling the EMC requirements and for proper operation of the module.

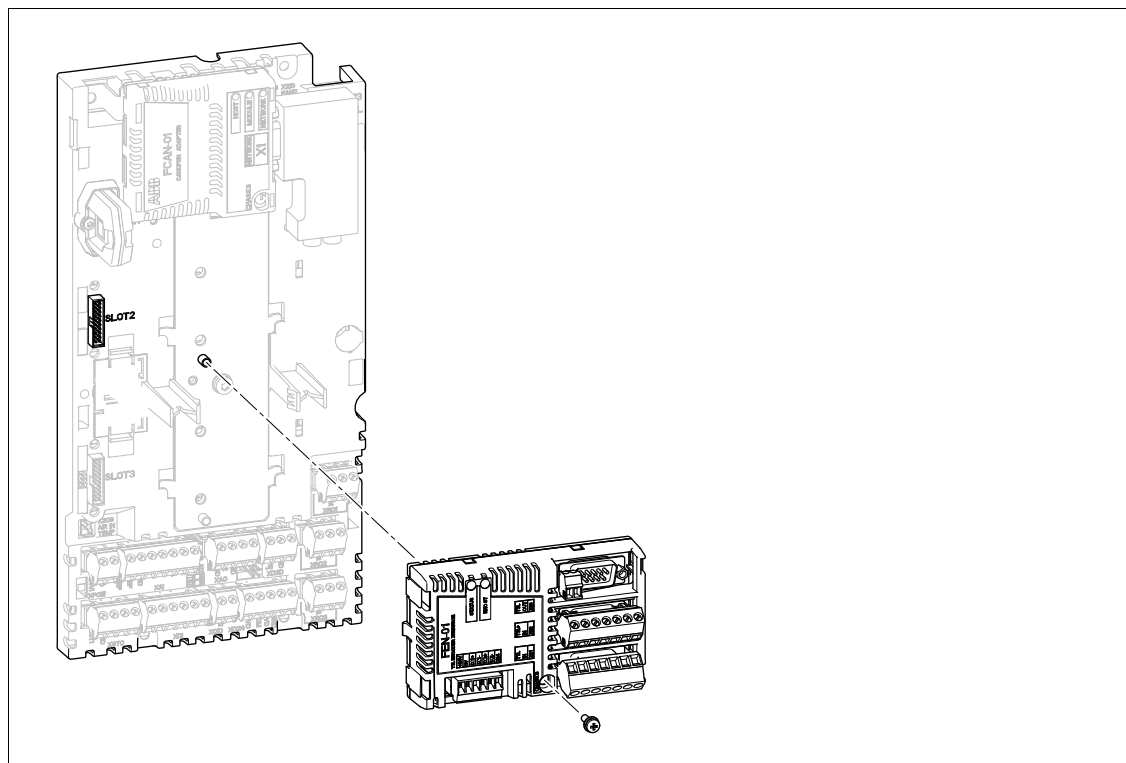

■ Wiring I/O extension, fieldbus adapter and pulse encoder interface modules

See the appropriate option module manual for specific installation and wiring instructions.

■ Installation of safety functions modules (frames R6 to R9)

Mount the safety functions module next to the control unit as described below.



WARNING! Obey the instructions in chapter [Safety instructions](#). If you ignore them, injury or death, or damage to the equipment can occur.

1. Stop the drive and do the steps in section [Precautions before electrical work](#) on page [16](#) before you start the work.
2. Open the swing-out frame.
3. Insert the module carefully into its position.
4. Attach the module with four screws. **Note:** Correct installation of the grounding screw (a) is essential for fulfilling the EMC requirements and for proper operation of the module.
5. Tighten the grounding screw of the electronics to 0.8 N·m.
6. Connect the data communication cable to connector X110 on the module and to connector X12 on the drive control unit.
7. Connect the Safe torque off four-wire cable to connector X111 on the module and to connector XSTO on the drive module control unit.
8. Connect the external +24 V power supply cable to connector X112.
9. Connect the other wires as shown in *FSO-12 safety functions module user's manual* (3AXD50000015612 [English]).

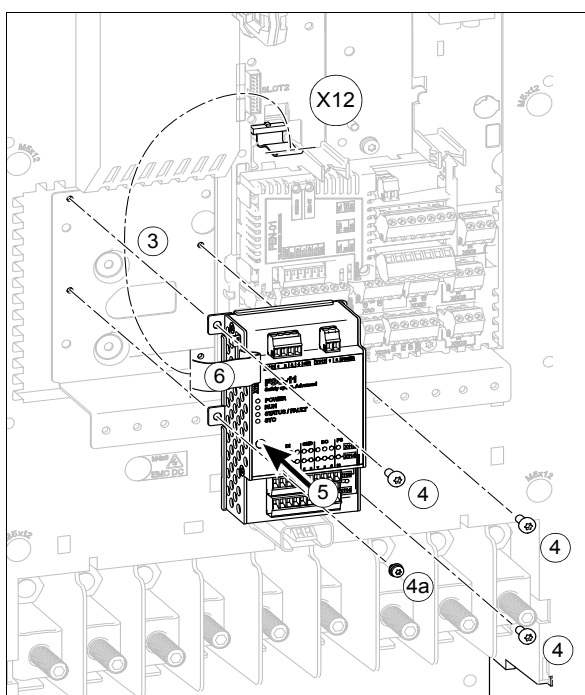

■ installation of safety functions modules (frames R10 and R11)

Install the safety functions module next to the control unit as described below. Change the mounting plate of the module as shown in *FSO-12 safety functions module user's manual* (3AXD50000015612 [English]).



WARNING! Obey the instructions in chapter [Safety instructions](#). If you ignore them, injury or death, or damage to the equipment can occur.

Case 1: FSO-xx safety functions module on Slot 2

1. Stop the drive and do the steps in section [Precautions before electrical work](#) on page [16](#) before you start the work.
2. Connect the FSO-xx data cable to connector X12 on the control unit.
3. Fasten the FSO-xx safety functions module to Slot 2 with four screws.
4. Tighten the FSO-xx electronics grounding screw to 0.8 N·m. **Note:** The screw tightens the connections and grounds the module. It is essential for fulfilling the EMC requirements and for proper operation of the module.
5. Connect the FSO-xx data cable to FSO-xx connector X110.
6. Connect the Safe torque off four-wire cable to connector X111 on the module and to connector XSTO on the drive module control unit.
7. Connect the external +24 V power supply cable to connector X112.
8. Connect the other wires as shown in *FSO-12 safety functions module user's manual* (3AXD50000015612 [English]).



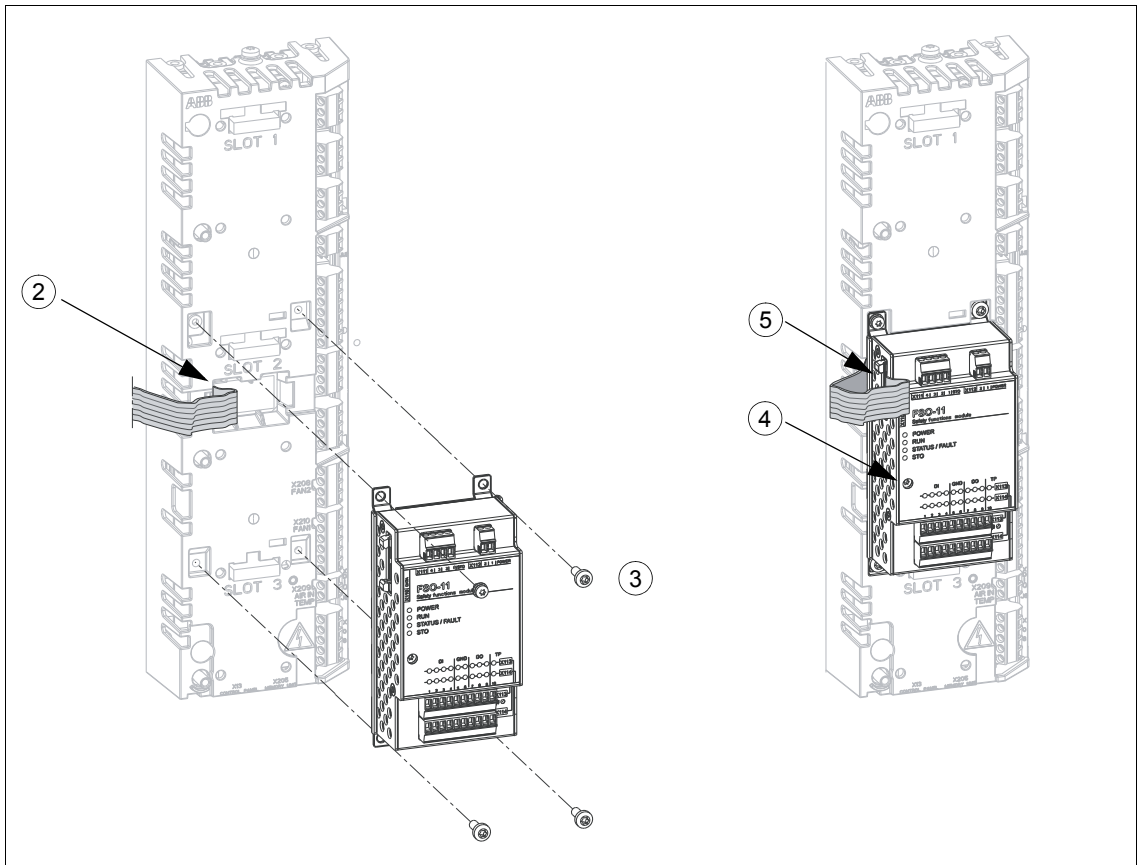

Case 2: FSO-xx safety functions module above the control unit

Install the safety functions module next to the control unit as described below. Change the original mounting plate of the module to the alternative plate included in the module package.



WARNING! Obey the instructions in chapter [Safety instructions](#). If you ignore them, injury or death, or damage to the equipment can occur.

1. Stop the drive and do the steps in section [Precautions before electrical work](#) on page [16](#) before you start the work.
2. Attach the FSO-xx safety functions module to the mounting plate with four screws.
3. Tighten the FSO-xx electronics grounding screw to 0.8 N·m. **Note:** The screw tightens the connections and grounds the module. It is essential for fulfilling the EMC requirements and for proper operation of the module.
4. Connect the FSO-xx data cable to FSO-xx connector X110 and to connector X12 on the control unit.

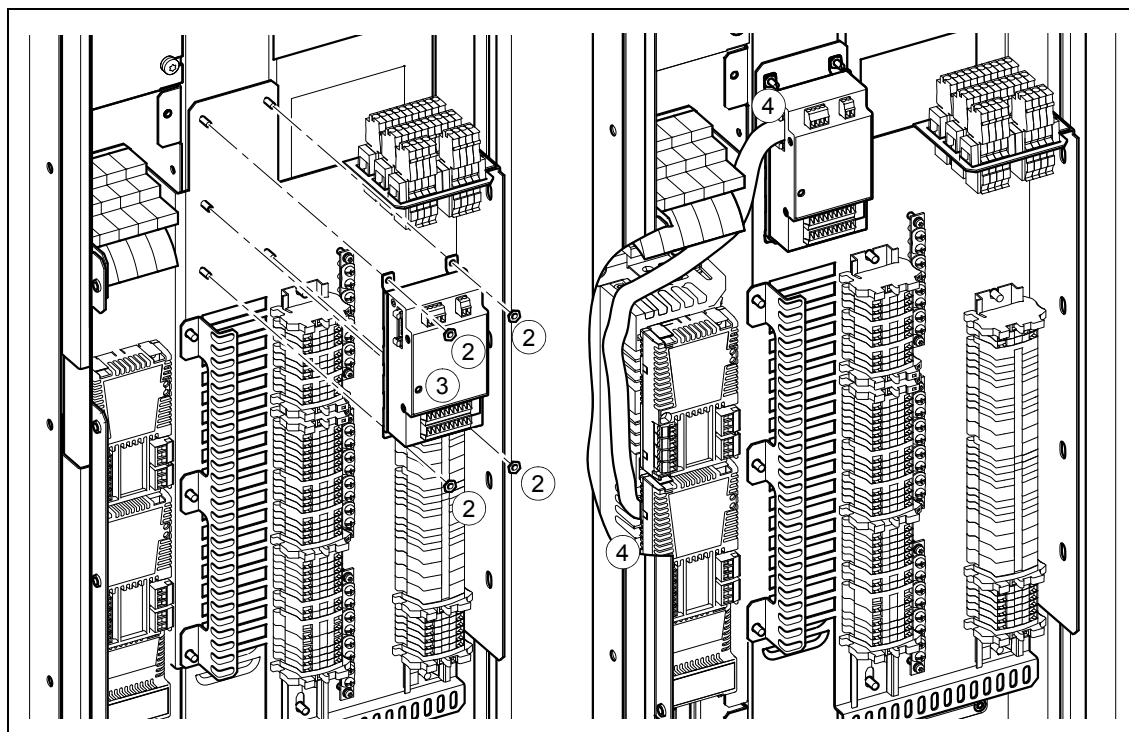

7

Control unit of frames R6 to R9

Contents of this chapter

This chapter contains the default I/O connection diagram, descriptions of the terminals and technical data for the control unit (ZCU-12) of drive frames R6 to R9.



Layout

The layout of external control connection terminals of the control unit is shown below.

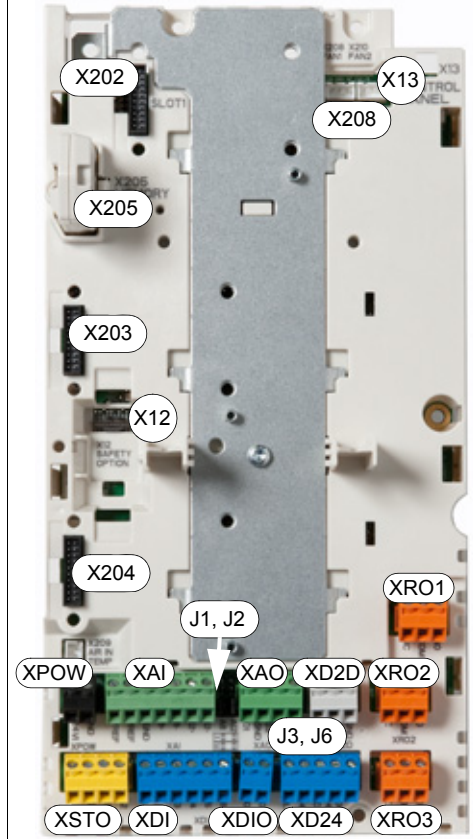

	Description
XPOW	External power input
XAI	Analog inputs
XAO	Analog outputs
XD2D	Drive-to-drive link
XRO1	Relay output 1
XRO2	Relay output 2
XRO3	Relay output 3
XD24	Start interlock connection (DIIL) and +24 V output
XDIO	Digital input/outputs
XDI	Digital inputs
XSTO	Safe torque off connection
X12	Connector for optional safety functions modules
X13	Control panel connection
X202	Option slot 1
X203	Option slot 2
X204	Option slot 3
X205	Memory unit connection
X208	Auxiliary cooling fan connection
J1, J2	Voltage/Current selection jumpers (J1, J2) for analog inputs
J3, J6	Drive-to-drive link termination jumper (J3), common digital input ground selection jumper (J6)



Default I/O connection diagram of frames R6 to R9

XPOW External power input		
1	+24V1	24 V DC, 2 A
2	GND	
XAI Reference voltage and analog inputs		
1	+VREF	10 V DC, R_L 1...10 kohm
2	-VREF	-10 V DC, R_L 1...10 kohm
3	AGND	Ground
4	AI1+	Speed reference 0(2)...10 V, $R_{in} > 200$ kohm ¹⁾
5	AI1-	
6	AI2+	By default not in use. 0(4)...20 mA, $R_{in} = 100$ ohm ²⁾
7	AI2-	
J1	J1	AI1 current/voltage selection jumper
J2	J2	AI2 current/voltage selection jumper
XAO Analog outputs		
1	AO1	Motor speed rpm 0...20 mA, $R_L < 500$ ohm
2	AGND	
3	AO2	Motor current 0...20 mA, $R_L < 500$ ohm
4	AGND	
XD2D Drive-to-drive link		
1	B	Drive-to-drive link
2	A	
3	BGND	
J3	J3	Drive-to-drive link termination switch
XRO1, XRO2, XRO3 Relay outputs		
11	NC	Ready 250 V AC / 30 V DC 2 A
12	COM	
13	NO	
21	NC	Running 250 V AC / 30 V DC 2 A
22	COM	
23	NO	
31	NC	Faulted(-1) 250 V AC / 30 V DC 2 A
32	COM	
33	NO	
XD24 Digital interlock		
1	DIIL	Run enable
2	+24VD	+24 V DC 200 mA ³⁾
3	DICOM	Digital input ground
4	+24VD	+24 V DC 200 mA ³⁾
5	DIOGN	Digital input/output ground
J6	Ground selection switch	
XDIO Digital input/outputs		
1	DIO1	Output: Ready
2	DIO2	Output: Running
XDI Digital inputs		
1	DI1	Stop (0) / Start (1)
2	DI2	Forward (0) / Reverse (1)
3	DI3	Reset
4	DI4	Acceleration & deceleration select ⁴⁾
5	DI5	Constant speed 1 (1 = On) ⁵⁾
6	DI6	By default not in use.
XSTO Safe torque off		
1	OUT1	Safe torque off. Both circuits must be closed for the drive to start.
2	SGND	
3	IN1	
4	IN2	
X12 Safety functions module connection		
X13 Control panel connection		
X205 Memory unit connection		

Accepted control unit terminal wire sizes: 0.5 ... 2.5 mm² (24...12 AWG). Tightening torques: 0.5 N·m (5 lbf·in) for both stranded and solid wiring. For terminal X504 (option +L504), see page 47. See the page 128 for the notes.

Notes:

- 1) Current [0(4)...20 mA, $R_{in} = 100 \text{ ohm}$] or voltage [0(2)...10 V, $R_{in} > 200 \text{ kohm}$] input selected with jumper J1. Change of setting requires reboot of control unit.
- 2) Current [0(4)...20 mA, $R_{in} = 100 \text{ ohm}$] or voltage [0(2)...10 V, $R_{in} > 200 \text{ kohm}$] input selected with jumper J2. Change of setting requires reboot of control unit.
- 3) Total load capacity of these outputs is 4.8 W (200 mA / 24 V) minus the power taken by DIO1 and DIO2.
- 4) 0 = open, 1 = closed

D14	Ramp times according to
0	Parameters 23.12 and 23.13
1	Parameters 23.14 and 23.15

5) Constant speed 1 is defined by parameter 22.26.

Further information on the usage of the connectors and jumpers is given in the sections below. For the technical data of the connectors, see section [Technical data](#) on page 131.

■ Jumpers and switches

Jumper/ Switch	Description	Positions
J1 (AI1)	Determines whether analog input AI1 is used as a current or voltage input.	Current (I)
		Voltage (V)
J2 (AI2)	Determines whether analog input AI2 is used as a current or voltage input.	Current (I)
		Voltage (U)
J3	Drive-to-drive link termination. Must be set to terminated position when the drive is the last unit on the link.	Bus is terminated.
		Bus is not terminated.
J6	Common digital input ground selection switch. Determines whether DICOM is separated from DIOGND (ie, common reference for digital inputs floats). See the Ground isolation diagram on page 133.	DICOM and DIOGND connected (default). DICOM and DIOGND separated.

■ External power supply for the control unit

External +24 V (2 A) power supply for the control unit can be connected to terminal block XPOW. Using an external supply is recommended if

- the control unit needs to be kept operational during input power breaks, for example, due to uninterrupted fieldbus communication
- immediate restart is needed after power breaks (that is, no control unit power up delay is allowed).

See also the firmware manual, parameter **95.04**.

■ AI1 and AI2 as Pt100, Pt1000, PTC and KTY84 sensor inputs (XAI, XAO)

Three Pt100, Pt1000 or PTC sensors or one KTY84 sensor for motor temperature measurement can be connected between an analog input and output as shown below. (Alternatively, you can connect the KTY to FIO-11 analog I/O extension module or FEN-xx encoder interface module.) Do not connect both ends of the cable shields directly to ground. If a capacitor cannot be used at one end, leave that end of the shield unconnected.

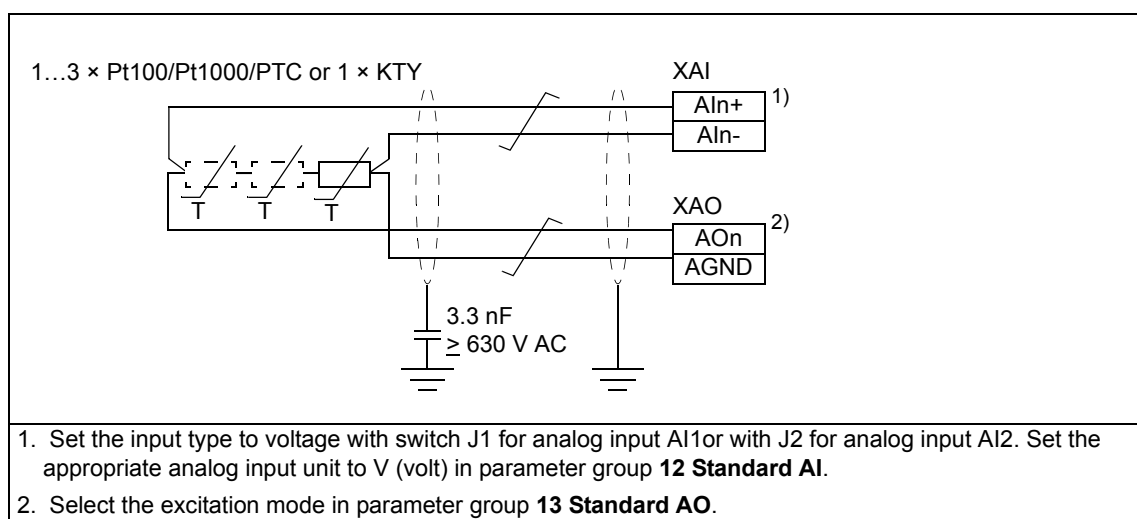

WARNING! As the inputs pictured above are not insulated according to IEC 60664, the connection of the motor temperature sensor requires double or reinforced insulation between motor live parts and the sensor. If the assembly does not fulfill the requirement, the I/O board terminals must be protected against contact and must not be connected to other equipment or the temperature sensor must be isolated from the I/O terminals.



■ DI6 (XDI:6) as PTC sensor input

A PTC sensor can be connected to this input for motor temperature measurement as follows. The sensor resistance must not exceed the threshold resistance of the digital input at the motor normal operating temperature. Do not connect both ends of the cable shield directly to ground. If a capacitor cannot be used at one end, leave that end of the shield unconnected. See the firmware manual for parameter settings.

Note: PTC sensors can alternatively be connected to FEN-xx encoder interface module.

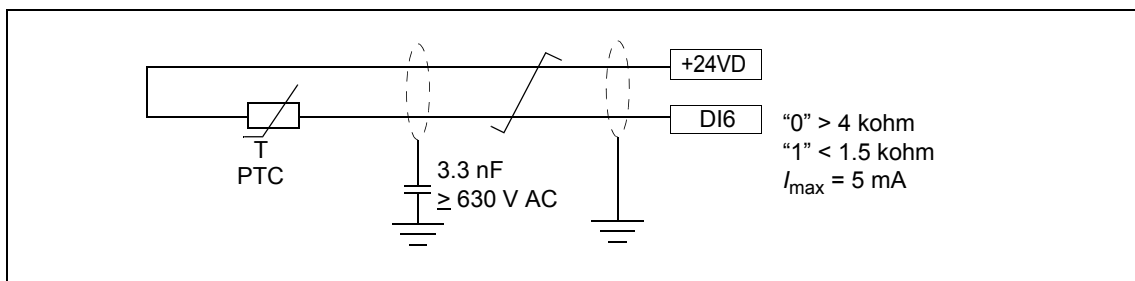

WARNING! As the inputs pictured above are not insulated according to IEC 60664, the connection of the motor temperature sensor requires double or reinforced insulation between motor live parts and the sensor. If the assembly does not fulfill the requirement, the I/O board terminals must be protected against contact and must not be connected to other equipment or the temperature sensor must be isolated from the I/O terminals.

■ DIIL input (XD24:1)

The DIIL input can be selected as the source of, for example, an emergency stop command or an external event. See the firmware manual, for more information

■ Drive-to-drive link (XD2D)

The drive-to-drive link is a daisy-chained RS-485 transmission line that allows basic master/follower communication with one master drive and multiple followers.

Set termination activation jumper J3 (see section [Jumpers and switches](#) above) next to this terminal block to the ON position on the drives at the ends of the drive-to-drive link. On intermediate drives, set the jumper to the OFF position.

Use shielded twisted-pair cable (~100 ohm, for example, PROFIBUS-compatible cable) for the wiring. For best immunity, high quality cable is recommended. Keep the cable as short as possible; the maximum length of the link is 100 meters (328 ft). Avoid unnecessary loops and running the cable near power cables (such as motor cables).

This diagram shows the wiring of the drive-to-drive link for frames R6 to R9.

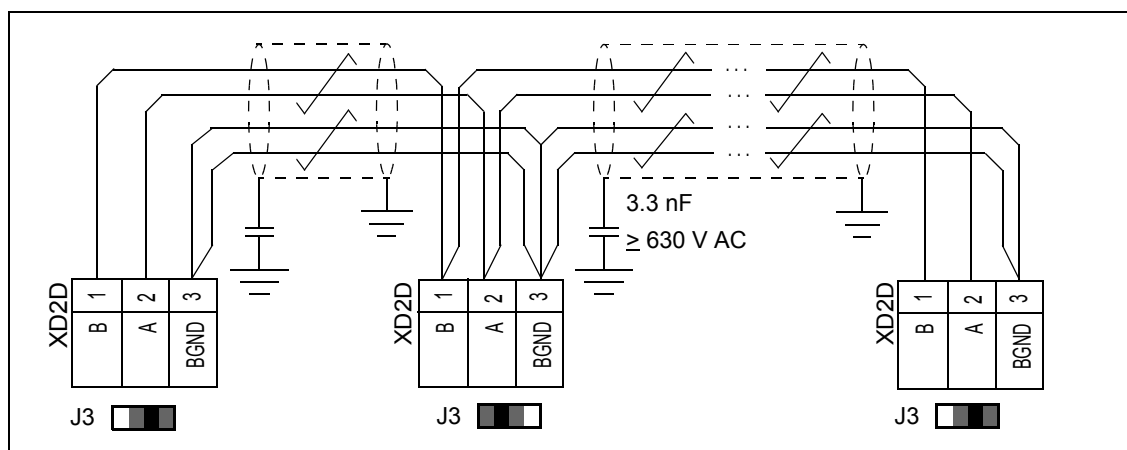

■ Safe torque off (XSTO)

For the drive to start, both connections (OUT1 to IN1 and IN2) must be closed. By default, the terminal block has jumpers to close the circuit. Remove the jumpers before connecting an external Safe torque off circuitry to the drive. See chapter [Safe torque off function](#) on page 229.

■ Safety functions module connection (X12)

See section [Implementing the functions provided by the FSO-xx safety functions module \(option +Q972 or +Q973\)](#) on page 86, chapter [Safe torque off function](#) and [FSO-12 safety functions module user's manual \(3AXD50000015612 \[English\]\)](#).

Technical data

Power supply (XPOW)	24 V ($\pm 10\%$) DC, 2 A Supplied from the power unit of the drive, or from an external power supply through connector XPOW. Connector pitch 5 mm (0.2 in), wire size 2.5 mm ² (14 AWG).
Relay outputs RO1...RO3 (XRO1 ... XRO3)	Connector pitch 5 mm (0.2 in), wire size 2.5 mm ² (14 AWG) 250 V AC / 30 V DC, 2 A Protected by varistors
+24 V output (XD24:2 and XD24:4)	Connector pitch 5 mm (0.2 in), wire size 2.5 mm ² (14 AWG) Total load capacity of these outputs is 4.8 W (200 mA / 24 V) minus the power taken by DIO1 and DIO2.
Digital inputs DI1...DI6 (XDI:1 ... XDI:6)	Connector pitch 5 mm (0.2 in), wire size 2.5 mm ² (14 AWG) 24 V logic levels: "0" < 5 V, "1" > 15 V R_{in} : 2.0 kohm Input type: NPN/PNP (DI1...DI5), NPN (DI6) Hardware filtering: 0.04 ms, digital filtering up to 8 ms DI6 (XDI:6) can alternatively be used as an input for PTC sensors. "0" > 4 kohm, "1" < 1.5 kohm I_{max} : 15 mA (for DI6 5 mA)
Start interlock input DIIL (XD24:1)	Connector pitch 5 mm (0.2 in), wire size 2.5 mm ² (14 AWG) 24 V logic levels: "0" < 5 V, "1" > 15 V R_{in} : 2.0 kohm Input type: NPN/PNP Hardware filtering: 0.04 ms, digital filtering up to 8 ms



Digital inputs/outputs DIO1 and DIO2

(XDIO:1 and XDIO:2)

Input/output mode selection by parameters.

DIO1 can be configured as a frequency input (0...16 kHz with hardware filtering of 4 microseconds) for 24 V level square wave signal (sinusoidal or other wave form cannot be used). DIO2 can be configured as a 24 V level square wave frequency output. See the firmware manual, parameter group 11.

Connector pitch 5 mm (0.2 in), wire size 2.5 mm² (14 AWG)

As inputs:

24 V logic levels: "0" < 5 V, "1" > 15 V

R_{in}: 2.0 kohm

Filtering: 0.25 ms

As outputs:

Total output current from +24VD is limited to 200 mA.

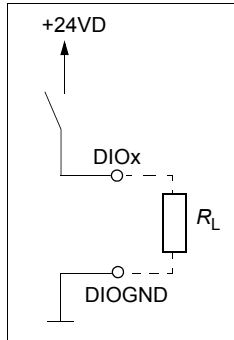

Reference voltage for analog inputs +VREF and -VREF

(XAI:1 and XAI:2)

Analog inputs AI1 and AI2 (XAI:4 ... XAI:7).

Current/voltage input mode selection by jumpers. See page 108.

Connector pitch 5 mm (0.2 in), wire size 2.5 mm² (14 AWG)

10 V ±1% and -10 V ±1%, R_{load} 1...10 kohm

Connector pitch 5 mm (0.2 in), wire size 2.5 mm² (14 AWG)

Current input: -20...20 mA, R_{in}: 100 ohm

Voltage input: -10...10 V, R_{in}: > 200 kohm

Differential inputs, common mode range ±30 V

Sampling interval per channel: 0.25 ms

Hardware filtering: 0.25 ms, adjustable digital filtering up to 8 ms

Resolution: 11 bit + sign bit

Inaccuracy: 1% of full scale range

Inaccuracy for Pt100 sensors: 10 °C (50 °F)

Analog outputs AO1 and AO2 (XAO)

Connector pitch 5 mm (0.2 in), wire size 2.5 mm² (14 AWG)

0...20 mA, R_{load} < 500 ohm

Frequency range: 0...300 Hz

Resolution: 11 bit + sign bit

Inaccuracy: 2% of full scale range

Drive to drive link (XD2D)

Connector pitch 5 mm (0.2 in), wire size 2.5 mm² (14 AWG)

Physical layer: RS-485

Termination by switch

Safe torque off connection (XSTO)

Connector pitch 5 mm (0.2 in), wire size 2.5 mm² (14 AWG)

Input voltage range: -3...30 V DC

Logic levels: "0" < 5 V, "1" > 17 V

For the drive to start, both connections must be closed (OUT1 to IN1 and IN2).

Current consumption of frames R1 to R7: 12 mA (+24 V DC, continuous) per STO channel

Current consumption of frames R8 and R9: 30 mA (+24 V DC, continuous) per STO channel

EMC (immunity) according to IEC 61326-3-1

Control panel / PC connection

Connector: RJ-45

Cable length < 3 m (10 ft)



The terminals on the board fulfil the Protective Extra Low Voltage (PELV) requirements. The PELV requirements of a relay output are not fulfilled if the relay is used with a voltage higher than 48 V.

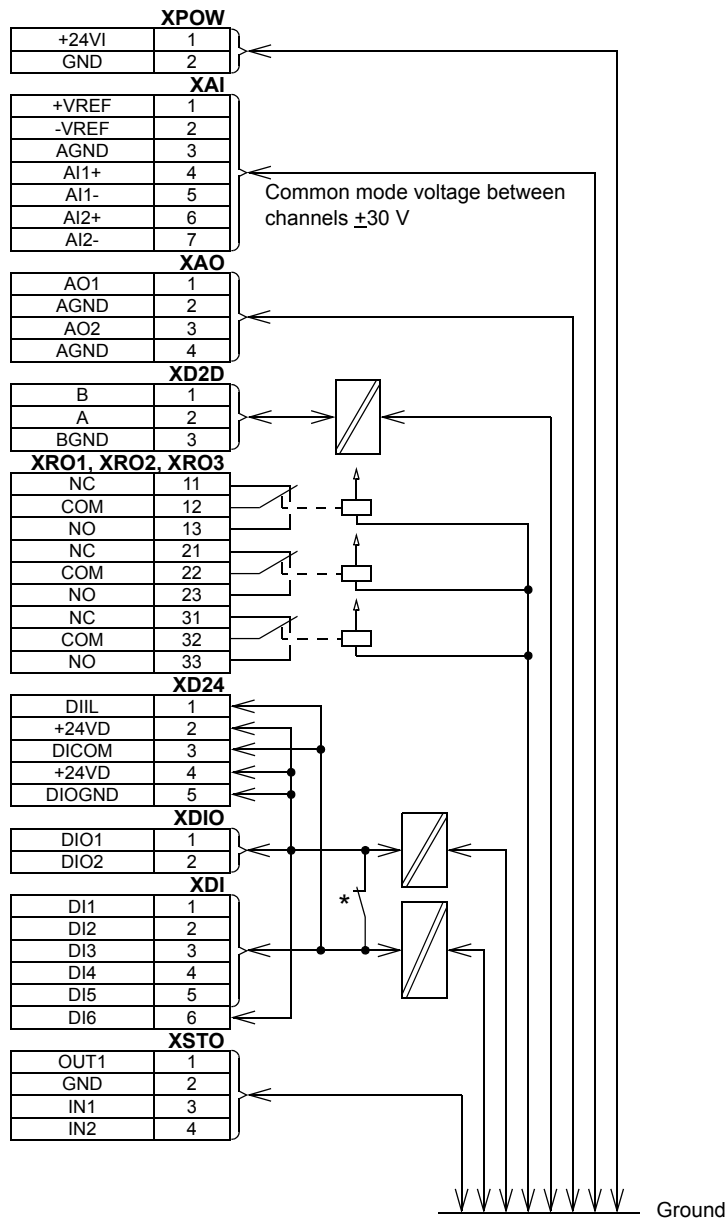

Ground isolation diagram



***Ground selector (J6) settings**

	(ZCU-12) All digital inputs share a common ground (DICOM connected to DIOGND). This is the default setting.
	(ZCU-12) Ground of digital inputs DI1...DI5 and DIIL (DICOM) is isolated from DIO signal ground (DIOGND). Isolation voltage 50 V.



8

Control unit of frames R10 and R11

Contents of this chapter

This chapter contains the default I/O connection diagram, descriptions of the terminals and technical data for the control unit (ZCU-14) of drive frames R10 and R11.



Layout

The layout of the external control connection terminals of the control unit is shown below.



The diagram shows the front panel of an ABB control unit with three slots (SLOT 1, SLOT 2, SLOT 3) and various terminal blocks. Labels in circles point to specific terminals: XRO1, XRO2, XRO3, XPOW, J1, J2, XAI, XAO, J3, XD2D, XSTO, XDI, XDIO, J6, XD24, X12, X13, X205, and X13. A screwdriver icon is located on the left side of the diagram.

Terminal Label	Description
XPOW	External power input
XAI	Analog inputs
XAO	Analog outputs
XD2D	Drive to drive link
XRO1	Relay output RO1
XRO2	Relay output RO2
XRO3	Relay output RO3
XD24	Start interlock connection (DIIL) and +24 V output
XDIO	Digital input/outputs)
XDI	Digital inputs)
XSTO	Safe torque off connection
X12	Connector for optional safety functions modules
X13	Control panel connection
Slot 1	Option module
Slot 2	Option module
Slot 3	Option module
X205	Memory unit
J1, J2	Voltage/Current selection jumpers (J1, J2) for analog inputs
J3	Drive-to-drive link termination jumper
J6	Common digital input ground selection jumper

Default I/O connection diagram of frames R10 and R11

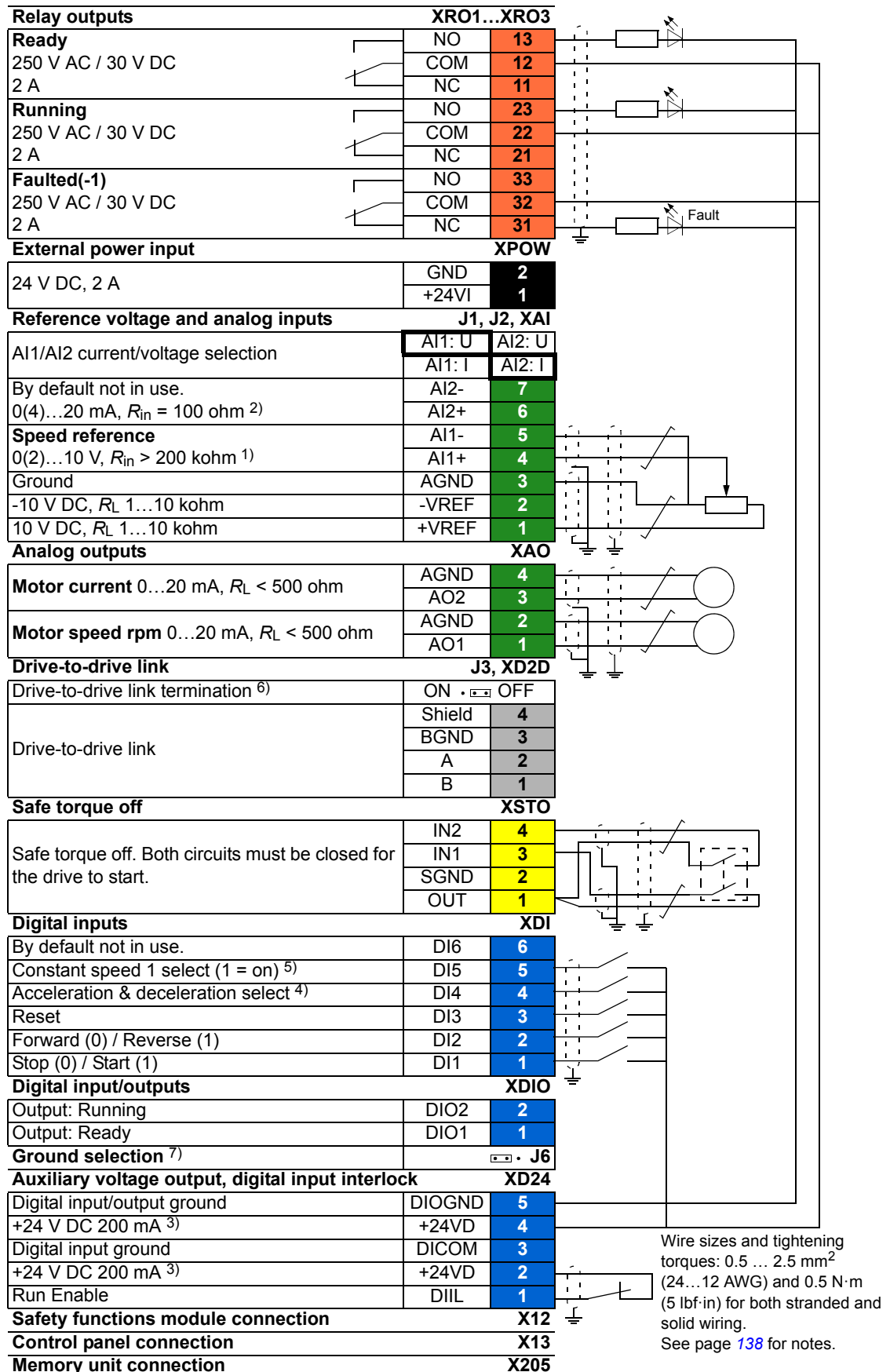

Notes:

- 1) Current [0(4)...20 mA, $R_{in} = 100 \text{ ohm}$] or voltage [0(2)...10 V, $R_{in} > 200 \text{ kohm}$] input selected with jumper J1. Change of setting requires reboot of control unit.
- 2) Current [0(4)...20 mA, $R_{in} = 100 \text{ ohm}$] or voltage [0(2)...10 V, $R_{in} > 200 \text{ kohm}$] input selected with jumper J2. Change of setting requires reboot of control unit.
- 3) Total load capacity of these outputs is 4.8 W (200 mA / 24 V) minus the power taken by tDIO1 and DIO2.
- 4) 0 = open, 1 = closed

DI4	Ramp times according to
0	Parameters 23.12 and 23.13
1	Parameters 23.14 and 23.15

- 5) Constant speed 1 is defined by parameter 22.26.
- 6) Must be set to ON when the drive is the last unit on the drive-to-drive (D2D) link.
- 7) Determines whether DICOM is separated from DIOGND (ie. common reference for digital inputs floats).
 DICOM connected to DIOGND. DICOM and DIOGND separate

Further information on the usage of the connectors and jumpers is given in the sections below.

See chapter [Control unit of frames R6 to R9](#) for the descriptions of

- External power supply for the control unit
- AI1 and AI2 as Pt100 and KTY84 sensor inputs (XAI, XAO)
- DI6 (XDI:6) as PTC sensor input
- DIIL input (XD24:1)
- Safe torque off (XSTO) ¹⁾
- Safety functions (X12)
- Technical data of the connectors.

¹⁾ Current consumption of frames R10 and R11 is 50 mA (+24 V DC, continuous) per STO channel. Logic levels: “0” < 5 V, “1” > 19 V.

Drive-to-drive link (XD2D)

The drive-to-drive link is a daisy-chained RS-485 transmission line that allows basic master/follower communication with one master drive and multiple followers.

Set termination activation jumper J3 next to this terminal block to the ON position on the drives at the ends of the drive-to-drive link. On intermediate drives, set the jumper to the OFF position.

Use shielded twisted-pair cable (~100 ohm, for example, PROFIBUS-compatible cable) for the wiring. For best immunity, high quality cable is recommended. Keep the cable as short as possible; the maximum length of the link is 100 meters (328 ft). Avoid unnecessary loops and running the cable near power cables (such as motor cables).



This diagram shows the wiring of the drive-to-drive link for frames R10 and R11.

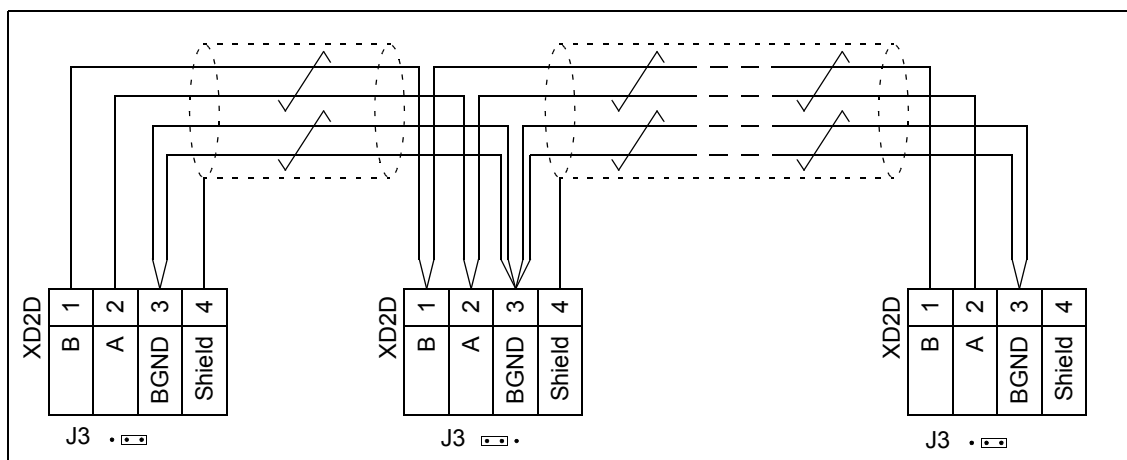

Ground isolation diagram

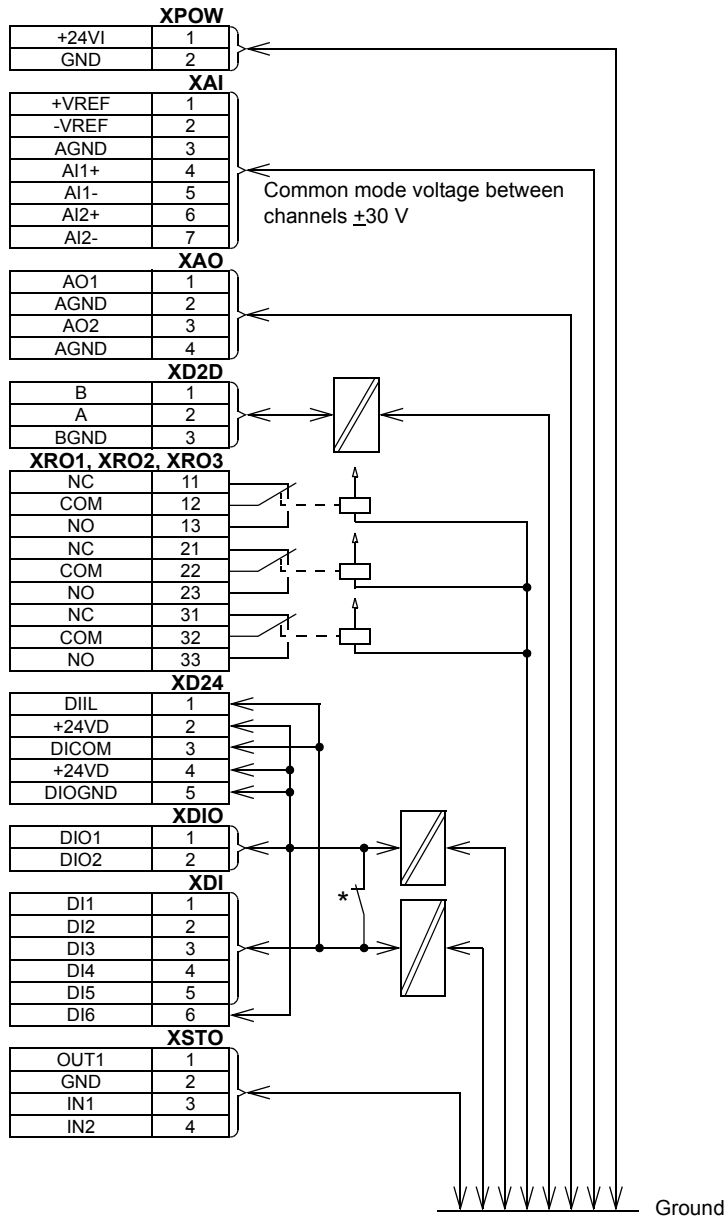

*Ground selector (J6) settings

<input type="checkbox"/> <input type="checkbox"/> (ZCU-14)	All digital inputs share a common ground (DICOM connected to DIOGND). This is the default setting.
<input type="checkbox"/> <input type="checkbox"/> (ZCU-14)	Ground of digital inputs DI1...DI5 and DIIL (DICOM) is isolated from DIO signal ground (DIOGND). Isolation voltage 50 V.

9

Installation checklist

Contents of this chapter

This chapter contains an installation checklist which you must complete before you start up the drive.

Warnings



WARNING! Obey the instructions in chapter [Safety instructions](#). If you ignore them, injury or death, or damage to the equipment can occur.

Checklist

Do the steps in section [Precautions before electrical work](#) on page 16 before you start the work. Go through the checklist together with another person..

Check that ...	<input checked="" type="checkbox"/>
The ambient operating conditions meet the specifications given in chapter Technical data .	<input type="checkbox"/>
The drive cabinet has been fixed to floor, and if necessary due to vibration etc, also from top to the wall or roof.	<input type="checkbox"/>
The cooling air will flow freely in and out of the drive cabinet,	<input type="checkbox"/>
<u>If the drive will be connected to an IT (ungrounded) or a corner grounded TN network:</u> The optional EMC filter (+E200, +E202) of the drive (if any) has been disconnected. See page 94.	<input type="checkbox"/>
<u>If the drive has been stored over one year:</u> The electrolytic DC capacitors in the DC link of the drive have been reformed. See Converter module capacitor reforming instructions (3BFE64059629 [English]).	<input type="checkbox"/>

Check that ...	<input checked="" type="checkbox"/>
There is an adequately sized protective earth (ground) conductor between the drive and the switchboard, and the conductor has been connected to appropriate terminal. Proper grounding has also been measured according to the regulations.	<input type="checkbox"/>
There is an adequately sized protective earth (ground) conductor between the motor and the drive, and the conductor has been connected to appropriate terminal. Proper grounding has also been measured according to the regulations.	<input type="checkbox"/>
<u>Only for drives with option +D150:</u> There is an adequately sized protective earth (ground) conductor between the user-installed brake resistor and the drive, and the conductor has been connected to appropriate terminal. Proper grounding has also been measured according to the regulations.	<input type="checkbox"/>
The supply voltage matches the nominal input voltage of the drive. Check the type designation label.	<input type="checkbox"/>
The voltage setting of the auxiliary voltage transformer (T21) is correct. See page 118.	<input type="checkbox"/>
The input power cable has been connected to the appropriate terminals, the phase order is right, and the terminals have been tightened. (Pull the conductors to check.)	<input type="checkbox"/>
The motor cable has been connected to the appropriate terminals, the phase order is right, and the terminals have been tightened. (Pull the conductors to check.)	<input type="checkbox"/>
The motor cable (and brake resistor cable, if present) has been routed away from other cables.	<input type="checkbox"/>
No power factor compensation capacitors have been connected to the motor cable.	<input type="checkbox"/>
<u>If a drive bypass connection will be used:</u> The direct-on-line contactor of the motor and the drive output contactor are either mechanically or electrically interlocked, ie, cannot be closed simultaneously.	<input type="checkbox"/>
The external brake resistor (if present) has been connected to the appropriate terminals, and the terminals have been tightened. (Pull the conductors to check.)	<input type="checkbox"/>
The brake resistor cable has been routed away from other cables.	<input type="checkbox"/>
The control cables have been connected to the appropriate terminals, and the terminals have been tightened. (Pull the conductors to check.)	<input type="checkbox"/>
There are no tools, foreign objects or dust from drilling inside the drive.	<input type="checkbox"/>
All shrouds and cover of the motor connection box are in place. Cabinet doors have been closed.	<input type="checkbox"/>
The motor and the driven equipment are ready for start.	<input type="checkbox"/>

10

Start-up

Contents of this chapter

This chapter contains the start-up procedure of the drive. The default device designations (if any) are given in brackets after the name, for example “main switch-disconnector (Q1)”. The same device designations are also used in the circuit diagrams, typically.

Start-up procedure

Action	<input checked="" type="checkbox"/>
Safety	
 WARNING! Obey the safety instructions during the start-up procedure. See chapter Safety instructions on page 13.	<input type="checkbox"/>
Checks/Settings with no voltage connected	
Check the mechanical and electrical installation of the drive. See Installation checklist on page 141.	<input type="checkbox"/>
<u>Drives with ground fault monitoring for IT (ungrounded) systems (option +Q954):</u> Adjust the settings of the ground fault monitor to suit the installation. See the circuit diagrams of the delivery and <i>IRDH275B Ground Fault Monitor Operating Manual</i> by Bender (code: TGH1386en).	<input type="checkbox"/>
<u>Drives with Pt100 relays (options +L506):</u> <ul style="list-style-type: none"> • Check the connections against the circuit diagrams of the delivery. • Set the alarm and trip levels of the Pt100 relays. Set the alarm and trip levels of the Pt100 relay as low as possible based on the operating temperature and test results of the machine. The trip level can be set, for example, 10 °C higher than what the temperature of the machine is at maximal load in the maximum environmental temperature. We recommend to set the operating temperatures of the relay, typically for example, as follows: <ul style="list-style-type: none"> • 120...140 °C when only tripping is in use • alarm 120...140 °C and trip 130...150 °C when both alarm and tripping are used. 	<input type="checkbox"/>



Action	<input checked="" type="checkbox"/>
Powering up the drive	
Close the cabinet doors.	<input type="checkbox"/>
Make sure that it is safe to connect voltage. Ensure that: <ul style="list-style-type: none"> • cabinet doors are closed • nobody is working on the drive or circuits that have been wired from outside into the drive cabinet • cover of the motor terminal box is on. 	<input type="checkbox"/>
Close the main switch-disconnector (Q1).	<input type="checkbox"/>
Setting up the drive parameters, and performing the first start	
Setup the drive control program. See the appropriate start-up guide, or firmware manual. There is a separate start-up guide only for some control programs. For drives with resistor braking (optional): see also section Start-up in chapter Resistor braking . For option +N7502, see also For option +N7502, see also SynRM motor control program (option +N7502) for ACS880-01, ACS880-07, ACS850-04 and ACQ810-04 drives supplement (3AXD50000026332 [English]) . For drives with ABB sine filter, check that parameter 95.15 Special HW settings is set to ABB sine filter . For other sine filters, see Sine filter hardware manual (3AXD50000016814 [English]) . For drives with ABB motors in explosive atmospheres, see also ACS880 drives with ABB motors in explosive atmospheres (3AXD50000019585 [English]) . If you need more information on the use of the control panel, see ACS-AP-X Assistant control panels user's manual (3AUA0000085685 (English)) .	<input type="checkbox"/>
<u>Drives with main contactor (Q2, option +F250)</u> : Close the main contactor by turning the operating switch on the cabinet door from OFF into ON position.	<input type="checkbox"/>
Perform the first start of the drive and motor.	<input type="checkbox"/>
Stop the motor and drive.	<input type="checkbox"/>
<u>Drives with with a fieldbus adapter module (optional)</u> : Set the fieldbus parameters. Activate the appropriate assistant in the control program, or see the user's manual of the fieldbus adapter module, and the drive firmware manual. Not all control programs include assistants. Check that the communication works between the drive and the PLC.	<input type="checkbox"/>
<u>Drives with an encoder interface module (optional)</u> : Set the encoder parameters. Activate the appropriate assistant in the control program, or see the user's manual of the encoder interface module, and the drive firmware manual. Not all control programs include assistants.	<input type="checkbox"/>
On-load checks	
Check that the cooling fans rotate freely in the right direction, and the air flows upwards. A paper sheet set on the intake (door) gratings stays. The fans run noiselessly.	<input type="checkbox"/>
Check that the motor starts, stops and follows the speed reference in right direction when controlled with the control panel.	<input type="checkbox"/>
Check that the motor starts, stops and follows the speed reference in right direction when controlled through the customer-specific I/O or fieldbus.	<input type="checkbox"/>
<u>Drives in which the Safe torque off control circuit is connected in use</u> : Test and validate the operation of the Safe torque off function. Start-up including acceptance test on page 234 .	<input type="checkbox"/>
<u>Drives with an emergency stop circuit (options +Q951, +Q952, +Q963, +Q964, +Q978 and +Q979)</u> : Test and validate the operation of the emergency-stop circuit. See the delivery specific circuit diagrams and wiring, start-up and operating instructions of the option (see page 85).	<input type="checkbox"/>



Action	<input checked="" type="checkbox"/>
<u>Drives with the Prevention of unexpected start-up (options +Q950 and +Q957):</u> Test and validate the operation of the Prevention of unexpected start-up circuit. See the delivery specific circuit diagrams and wiring, start-up and operating instructions of the option (see page 86).	<input type="checkbox"/>





11

Fault tracing

Contents of this chapter

This chapter describes the fault tracing possibilities of the drive.

LEDs

Where	LED	Color	When the LED is lit
Control panel mounting platform	POWER	Green	Control unit is powered and +15 V is supplied to the control panel.
	FAULT	Red	Drive in fault state.

Warning and fault messages

See the firmware manual for the descriptions, causes and remedies of the drive control program warning and fault messages.

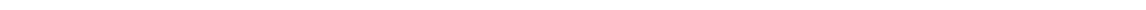



12

Maintenance

Contents of this chapter

This chapter contains preventive maintenance instructions.

Maintenance intervals

If installed in an appropriate environment, the drive requires very little maintenance. The table below lists the routine maintenance intervals recommended by ABB. The recommended maintenance intervals and component replacements are based on specified operational and environmental conditions.

Note: Long-term operation near the specified maximum ratings or environmental conditions may require shorter maintenance intervals for certain components.

The tables below contain user tasks. For tasks to be performed by ABB and more details on the maintenance, consult your local ABB Service representative. On the Internet, go to www.abb.com/searchchannels.

■ Descriptions of symbols

Action	Description
I	Visual inspection and maintenance action if needed
P	Performance of on/off-site work (commissioning, tests, measurements or other work)
R	Replacement of component

■ Recommended annual maintenance actions by the user

ABB recommends these annual inspections to ensure the highest reliability and optimum performance.

Action	Target
I	IP22 and IP42 air inlet and outlet meshes on the cabinet doors

Action	Target
R	IP54 air filters on the cabinet doors
P	Quality of supply voltage
I	Spare parts
P	Capacitor reforming, spare modules and spare capacitors
I	Tightness of terminals
I	Dustiness, corrosion or temperature
I	Heat sink cleaning

■ Recommended maintenance intervals after start-up

Component	Years from start-up							
	3	6	9	12	15	18	20	21
Cooling								
Main cooling fan								
Main cooling fan (R6 to R9)		R		R		R		
Main cooling fan (R10 and R11)			R			R		
Auxiliary cooling fan								
Auxiliary cooling fan for circuit boards (R6 to R9)	R	R	R	R	R	R	R	R
Auxiliary cooling fan IP55 (R8 and R9)	R	R	R	R	R	R	R	R
Circuit board compartment cooling fans (R10 and R11)		R		R		R		
Cabinet cooling fan								
Cabinet cooling fan, internal		R		R		R		
Cabinet cooling fan, door		R		R		R		
NSIN filter cooling fan								
NSIN filter cooling fan *	R	R	R	R	R	R	R	R
Aging								
Control panel battery and ZCU control unit battery		R		R		R		

4FPS10000239703

* Contact ABB Service for the filter change

Cleaning the interior of the cabinet



WARNING! Obey the instructions in chapter [Safety instructions](#). If you ignore them, injury or death, or damage to the equipment can occur.



WARNING! Use a vacuum cleaner with an antistatic hose and nozzle. Using a normal vacuum cleaner creates static discharges which can damage circuit boards.

1. Stop the drive and do the steps in section [Precautions before electrical work](#) on page [16](#) before you start the work.
2. When necessary, clean the interior of the cabinet with a soft brush and a vacuum cleaner.
3. Check the air inlet and outlet meshes/filters of the cabinet. Clean when necessary.
 For IP22 (UL Type 1) and IP42 (UL Type 1 Filtered) drives: see section [Cleaning the air inlet \(door\) meshes \(IP22 / UL Type 1, IP42 / UL Type 1 Filtered\)](#) below.
 For IP54 (UL Type 12) drives: see section [Replacing the air filters \(IP54 / UL Type 12\)](#).

Cleaning the air inlet (door) meshes (IP22 / UL Type 1, IP42 / UL Type 1 Filtered)



WARNING! Use a vacuum cleaner with an antistatic hose and nozzle. Using a normal vacuum cleaner creates static discharges which can damage circuit boards.

Check the dustiness of the air inlet meshes. If the dust cannot be removed by vacuum cleaning from outside through the grating holes with a small nozzle, proceed as follows:

1. Remove the fasteners at the top of the grating.
2. Lift the grating and pull it away from the door.
3. Remove the mesh by turning the clips gently a little.
4. Vacuum clean the mesh.
5. Reinstall the mesh and grating in reverse order.

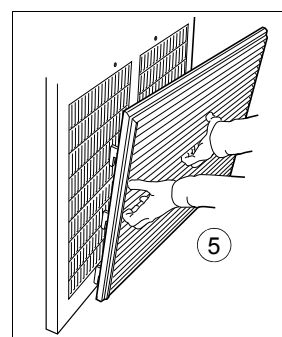
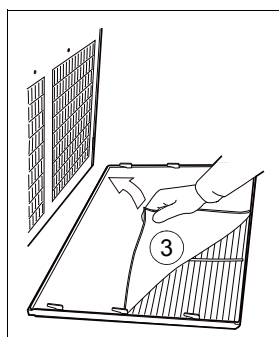
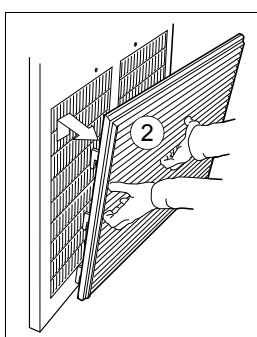
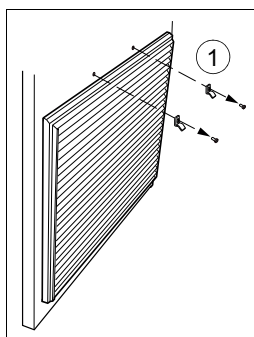

Replacing the air filters (IP54 / UL Type 12)

Check the air filters and replace if necessary (see page 208 for the correct filter types).

■ Inlet (door) filters (IP54 / UL Type 12)

1. Remove the fasteners at the top of the grating.
2. Lift the grating and pull it away from the door.
3. Remove the air filter mat.
4. Place the new filter mat in the grating the metal wire side facing the door.
5. Reinstall the grating in reverse order.

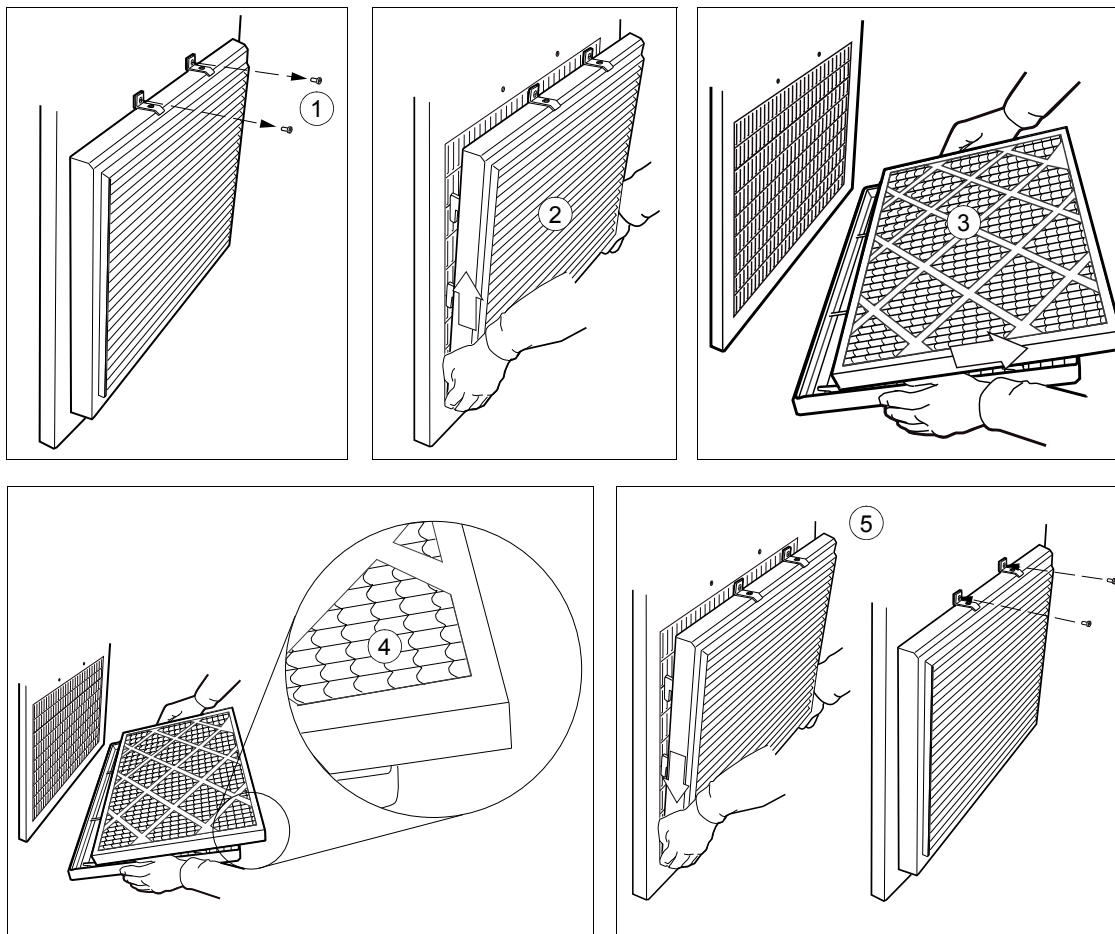

■ Outlet (roof) filters (IP54 / UL Type 12)

1. Remove the front and back gratings of the fan cubicle by lifting them upwards
2. Remove the air filter mat.
3. Place the new filter mat in the grating.
4. Reinstall the grating in reverse order.

Heatsink

The drive module heatsink fins pick up dust from the cooling air. The drive runs into overtemperature warnings and faults if the heatsink is not clean. When necessary, clean the heatsink as follows.



WARNING! Obey the instructions in chapter [Safety instructions](#). If you ignore them, injury or death, or damage to the equipment can occur.



WARNING! Use a vacuum cleaner with antistatic hose and nozzle. Using a normal vacuum cleaner creates static discharges which can damage circuit boards.

1. Stop the drive and do the steps in section [Precautions before electrical work](#) on page [16](#) before you start the work.
2. Remove the drive module from the cabinet.
3. Remove the module cooling fan(s). See section [Fans](#) below.
4. Blow dry clean compressed air (not humid or oily) from bottom to top and simultaneously use a vacuum cleaner at the air outlet to trap the dust. **Note:** If there is a risk of dust entering adjoining equipment, perform the cleaning in another room
5. Refit the cooling fan.

Fans

The lifespan of the cooling fan of the drive depends on the running time of the fan, ambient temperature and dust concentration. See the firmware manual for the actual signal which indicates the running time of the cooling fan. Reset the running time signal after a fan replacement.

Replacement fans are available from ABB. Do not use other than ABB specified spare parts.

■ Replacing the cabinet “door” fans



WARNING! Obey the instructions in chapter [Safety instructions](#). If you ignore them, injury or death, or damage to the equipment can occur.

1. Stop the drive and do the steps in section [Precautions before electrical work](#) on page [16](#) before you start the work.
2. Remove the mounting plate above the fan.
3. Loosen the four mounting screws of the fan mounting plate.
4. Lift the mounting plate upwards.
5. Unplug the power supply wires.
6. Lift the fan mounting plate off.
7. Remove the fan from the mounting plate.
8. Install the new fan in reverse order.

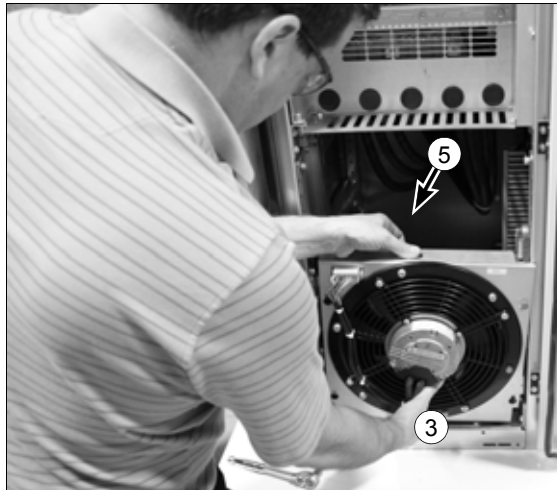

■ Replacing the cabinet fans (frames R6 to R9)

1. For removing the fan mounting plate, see section [Replacing the drive module \(frames R6 to R8\)](#) on page 164 (steps 1 to 3 and 13) or section [Replacing the drive module \(frame R9\)](#) on page 169 (steps 1, 9 and 10). For frame R9 with option +C129, see also below:

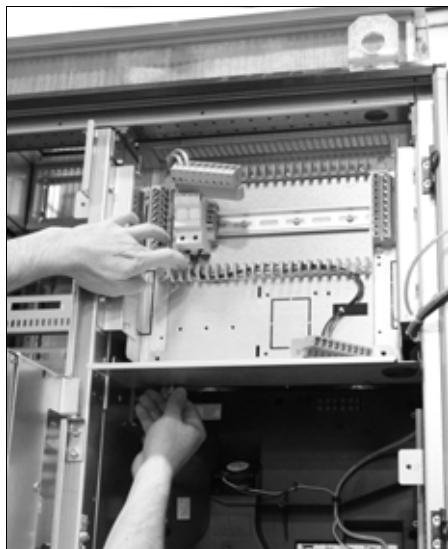

2. Remove the fan from the mounting plate.
 3. Install the new fan in reverse order.
-

■ Replacing the drive module main fans (frames R6 to R8)



WARNING! Obey the instructions in chapter [Safety instructions](#). If you ignore them, injury or death, or damage to the equipment can occur.

1. Stop the drive and do the steps in section [Precautions before electrical work](#) on page [16](#) before you start the work.
2. Slide the drive module forward as described under [Replacing the drive module \(frames R6 to R8\)](#) on page [164](#).
3. Undo the mounting screws of the fan mounting plate (view from bottom below).
4. Pull the fan mounting plate down from the side edge.
5. Unplug the power supply wires.
6. Lift the fan mounting plate off.
7. Remove the fan from the mounting plate.
8. Install the new fan in reverse order.
9. Reset the counter in group 5 in the primary control program.

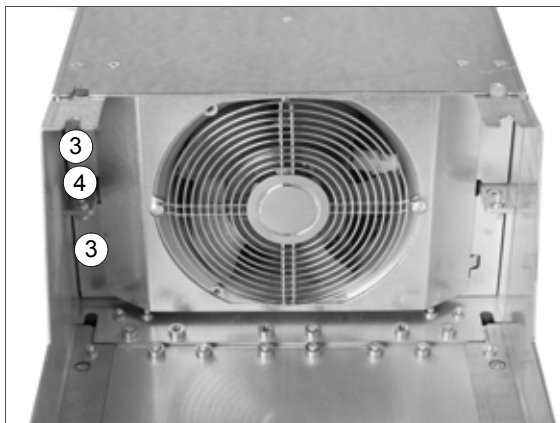

■ Replacing the auxiliary cooling fan of the drive module (frames R6 to R9)



WARNING! Obey the instructions in chapter [Safety instructions](#). If you ignore them, injury or death, or damage to the equipment can occur.

1. Stop the drive and do the steps in section [Precautions before electrical work](#) on page [16](#) before you start the work.
2. Unplug the power supply wires from the control unit terminal X208:FAN2.
3. Lift the fan up.
4. Install the new fan in reverse order. Make sure that the arrow on the fan points up.
5. Reset the counter in group 5 in the primary control program.

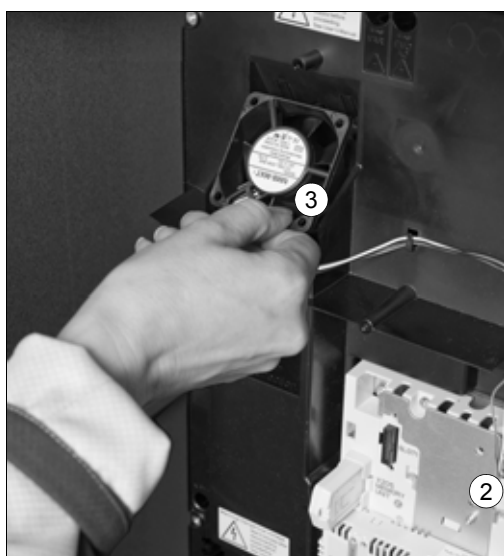

■ Replacing the drive module main fans (frame R9)



WARNING! Obey the instructions in chapter [Safety instructions](#). If you ignore them, injury or death, or damage to the equipment can occur.

1. Stop the drive and do the steps in section [Precautions before electrical work](#) on page [16](#) before you start the work.
2. Slide the drive module forward as described under [Replacing the drive module \(frame R9\)](#), page [169](#).
3. Undo the two mounting screws of the fan mounting plate (view from drive module bottom below).
4. Turn the mounting plate downwards.
5. Disconnect the fan power supply wires.
6. Remove the fan mounting plate.
7. Remove the fan by undoing the two mounting screws.
8. Install the new fan in reverse order.
9. Reset the counter in group 5 in the primary control program.

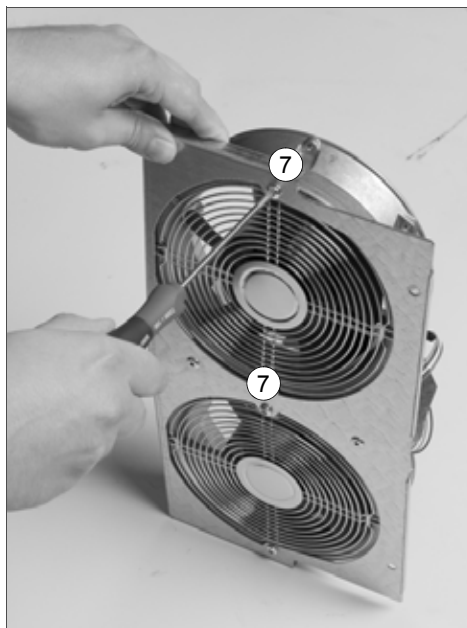
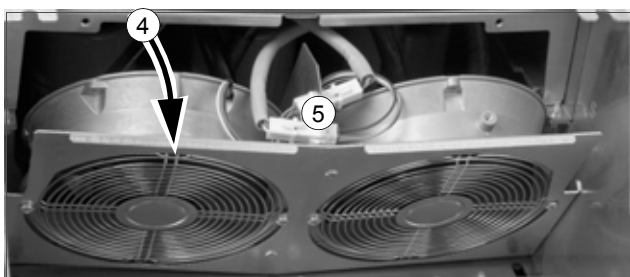
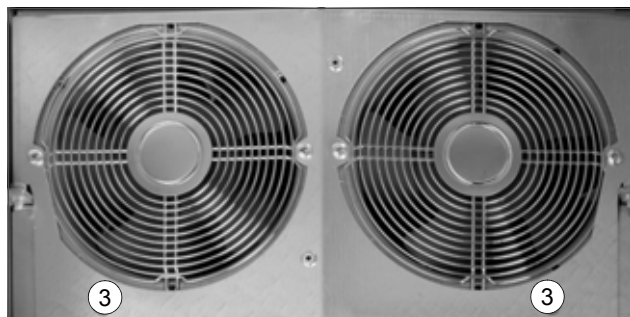

■ Replacing the drive module main fans (frames R10 and R11)



WARNING! Obey the instructions in chapter [Safety instructions](#). If you ignore them, injury or death, or damage to the equipment can occur.

1. Stop the drive and do the steps in section [Precautions before electrical work](#) on page [16](#) before you start the work.
2. Remove the drive module out of the cabinet as described in section [Replacing the drive module \(frames R10 and R11\)](#) on page [174](#).
3. Open the support legs of the pedestal.
4. Undo the two screws that fasten the fan assembly plate.
5. Tilt the fan assembly plate down.
6. Disconnect the power supply wires of the fans.
7. Remove the fan assembly from the drive module.
8. Undo the fastening screws of the fan(s) and remove the fan(s) from the assembly plate.
9. Install the new fan(s) in reverse order.
10. Reset the counter in group 5 in the primary control program.

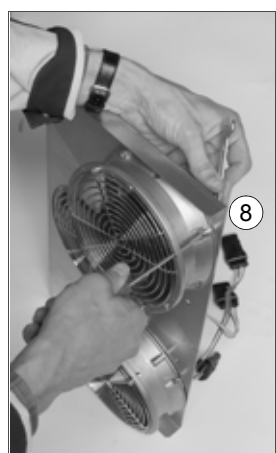

■ Replacing the circuit board compartment cooling fan (frames R10 and R11)



WARNING! Obey the instructions in chapter [Safety instructions](#). If you ignore them, injury or death, or damage to the equipment can occur.

1. Stop the drive and do the steps in section [Precautions before electrical work](#) on page [16](#) before you start the work.
2. Remove the drive module out of the cabinet as described in section [Replacing the drive module \(frames R10 and R11\)](#) on page [174](#).
3. Undo the fastening screw of the fan enclosure.
4. Unplug the power supply cable of the fan.
5. Install the new fan in reverse order.
6. Reset the counter in group 5 in the primary control program.

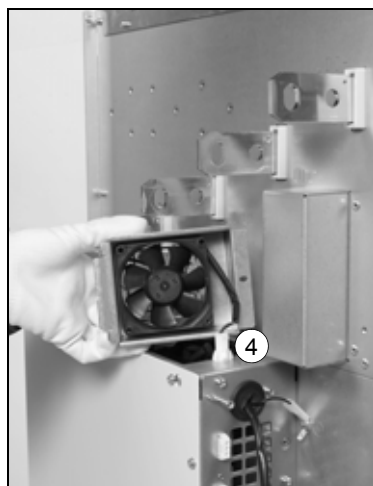

■ Replacing the IP54 (UL type 12) roof fan of frames R6 to R8



WARNING! Obey the instructions in chapter [Safety instructions](#). If you ignore them, injury or death, or damage to the equipment can occur.

1. Stop the drive and do the steps in section [Precautions before electrical work](#) on page [16](#) before you start the work.
2. Lift the front grating upwards and remove it.
3. Loosen the fastening screws of the front plate. Remove the plate.
4. Disconnect the fan supply wires.
5. Loosen the mounting screws of the fan.
6. Pull the fan out.
7. Install the new fan in reverse order.

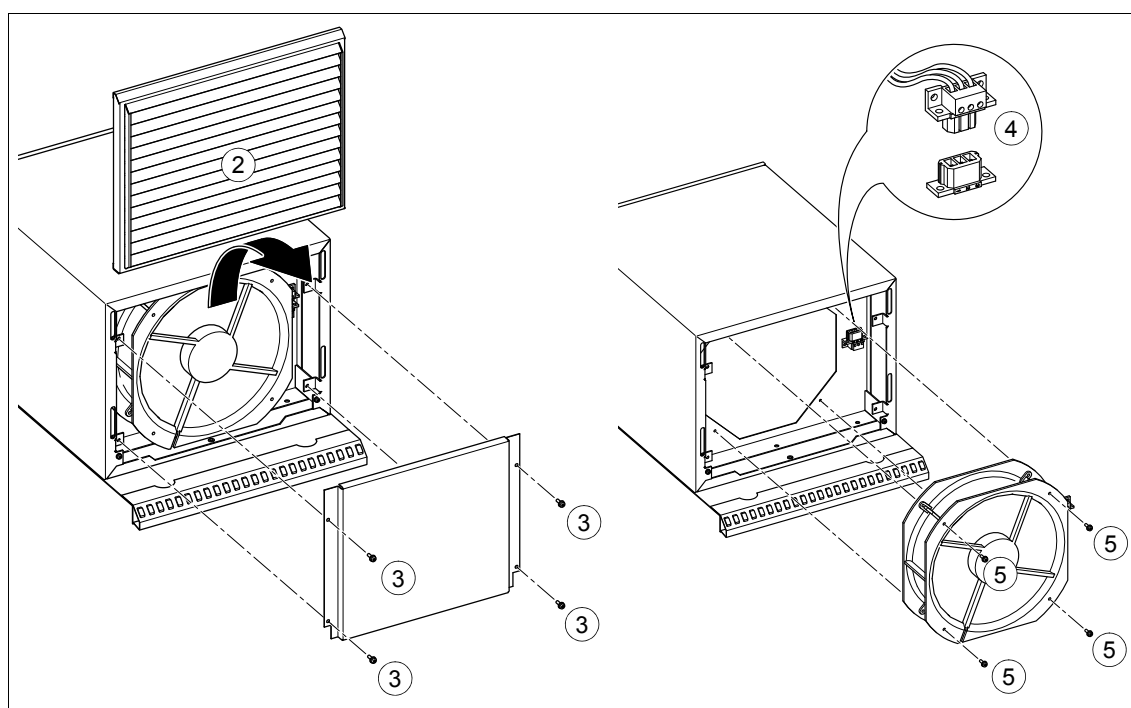

■ Replacing the IP54 (UL type 12) roof fan of frame R9



WARNING! Obey the instructions in chapter [Safety instructions](#). If you ignore them, injury or death, or damage to the equipment can occur.

1. Stop the drive and do the steps in section [Precautions before electrical work](#) on page [16](#) before you start the work.
2. Lift the front and back gratings upwards and remove them.
3. Loosen the mounting screws of the fan cover.
4. Lift the cover off.
5. Disconnect the fan supply wires.
6. Loosen the mounting screws of the fan.
7. Lift the fan off.
8. Install the new fan in reverse order.

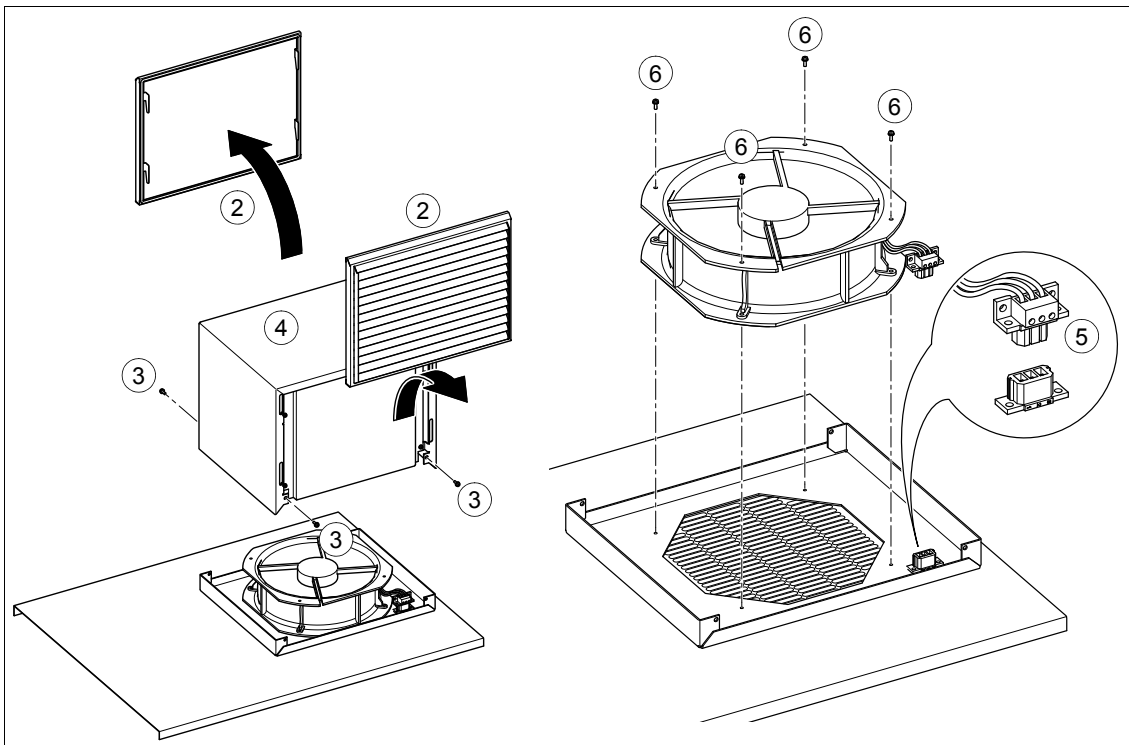

■ Replacing the IP54 (UL type 12) roof fan of frames R10 and R11



WARNING! Obey the instructions in chapter [Safety instructions](#). If you ignore them, injury or death, or damage to the equipment can occur.

1. Stop the drive and do the steps in section [Precautions before electrical work](#) on page [16](#) before you start the work.
2. Slide the front and back gratings upwards and remove them.
3. Remove the mounting screws of the upper cover and lift the cover off.
4. Disconnect the fan power supply wires.
5. Remove the mounting screws of the fan.
6. Remove the mounting screws of the fan cover.
7. Lift the fan off.
8. Install the new fan in reverse order.

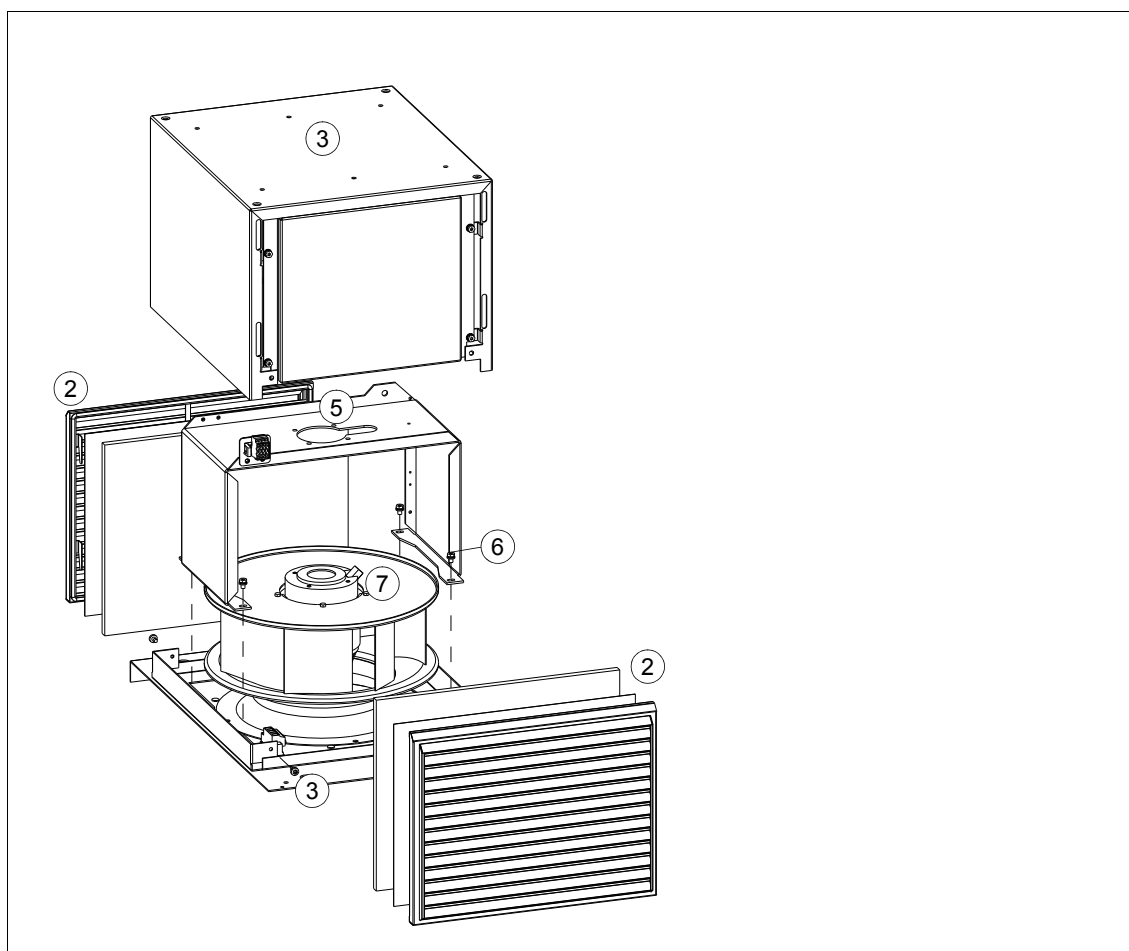

Replacing the drive module (frames R6 to R8)

Required in this replacing procedure: two persons, lifting chains, lifting device, a set of screw drivers and torque wrench with extension bar. A lifting device for ACS880-07 drive modules is available from ABB. For its installation and use, see *ACS880-07 lifting device user's manual* (3AUA0000131337 [English]).



WARNING! Obey the instructions in chapter [Safety instructions](#). If you ignore them, injury or death, or damage to the equipment can occur.



WARNING! Make sure that the cabinet is secured to the floor. If not, the cabinet can topple over when the heavy drive module is slid forward in front of the cabinet. This can cause injury or death, and damage to the equipment.



1. Stop the drive and do the steps in section [Precautions before electrical work](#) on page 16 before you start the work.
2. For drives with options +L505 and +L506: Remove the shroud.
3. For drives with options +L505 and +L506: Remove the Pt100 and thermistor relay mounting plate by loosening the two mounting screws and lifting the mounting plate up.
4. Undo the screws on the right-hand side of the swing-out frame.
5. Undo the hinge screw at the top and bottom of the swing-out frame to enable the frame to open aside far enough.
6. Unplug the control wire terminals at the right-hand side of the cabinet.
7. Remove the mounting plate above the “door” fan by loosening the mounting screws and lifting the plate up. For drives with options +G300, +G301, +G307 and +G313: Unplug the control cable terminals at the back side of the mounting plate.
8. Unplug the control cable terminals from the control unit. Disconnect the control cables from the option modules on the control unit.
9. For drives with additional terminal block (option +L504): Disconnect the control cables from terminal block X504 and remove the terminal block by loosening the mounting screws and lifting it forwards.
10. Disconnect the input and motor cabling busbars from the drive module terminals.
11. Drives with option +D150 or +D151: Disconnect the resistor busbars from the drive module terminals.
12. Drives with option +H356: Disconnect the DC busbars from the drive module terminals.
13. Unplug the cabinet fan power supply cables and remove the fan assembly above the drive module.
14. Remove the slide extension rails from the left-hand side of the cabinet by undoing the mounting screws.
15. Install the extension rails at the end of the sliding bars.

16. Undo the upper mounting nuts of the drive module.
 17. Undo the lower mounting nuts of the drive module.
 18. Slide the drive module towards the end of the sliding bars.
 19. Secure the drive module with chains from the lifting eyes.
 20. Lift the module out of the cabinet with the lifting device.
 21. Install the new module in reverse order.
-

R6 to R8

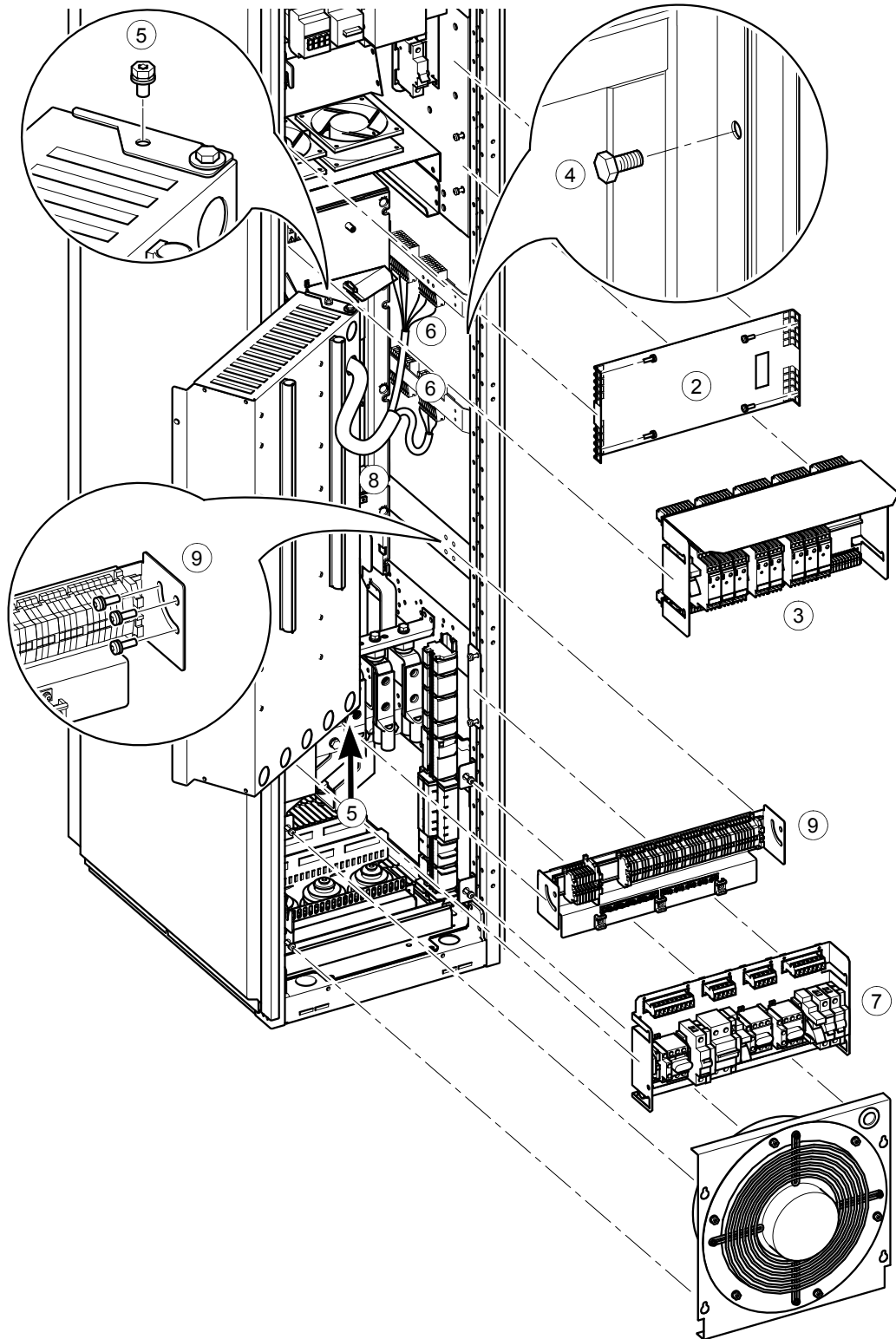

R6 to R8

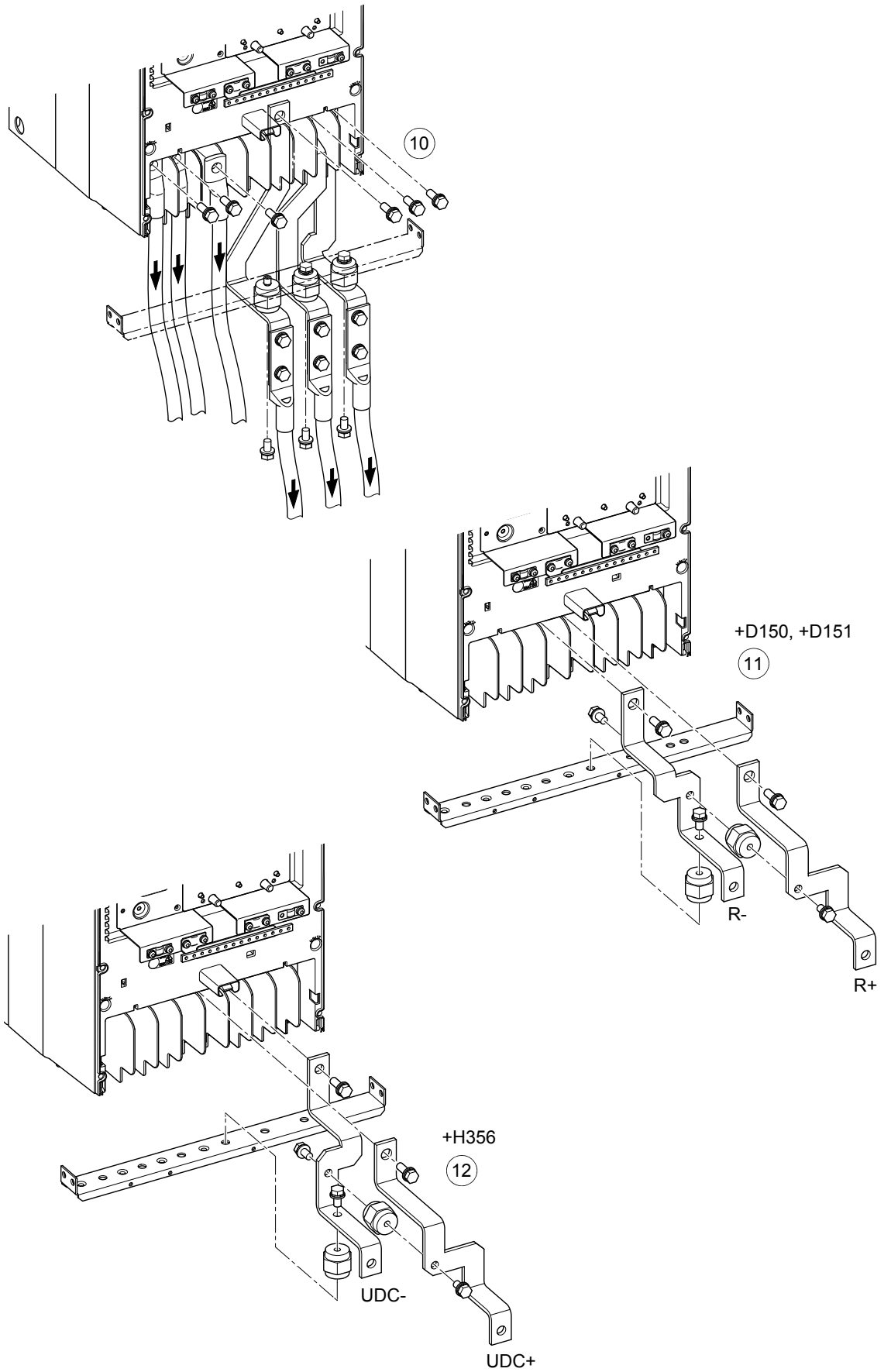

R6 to R9

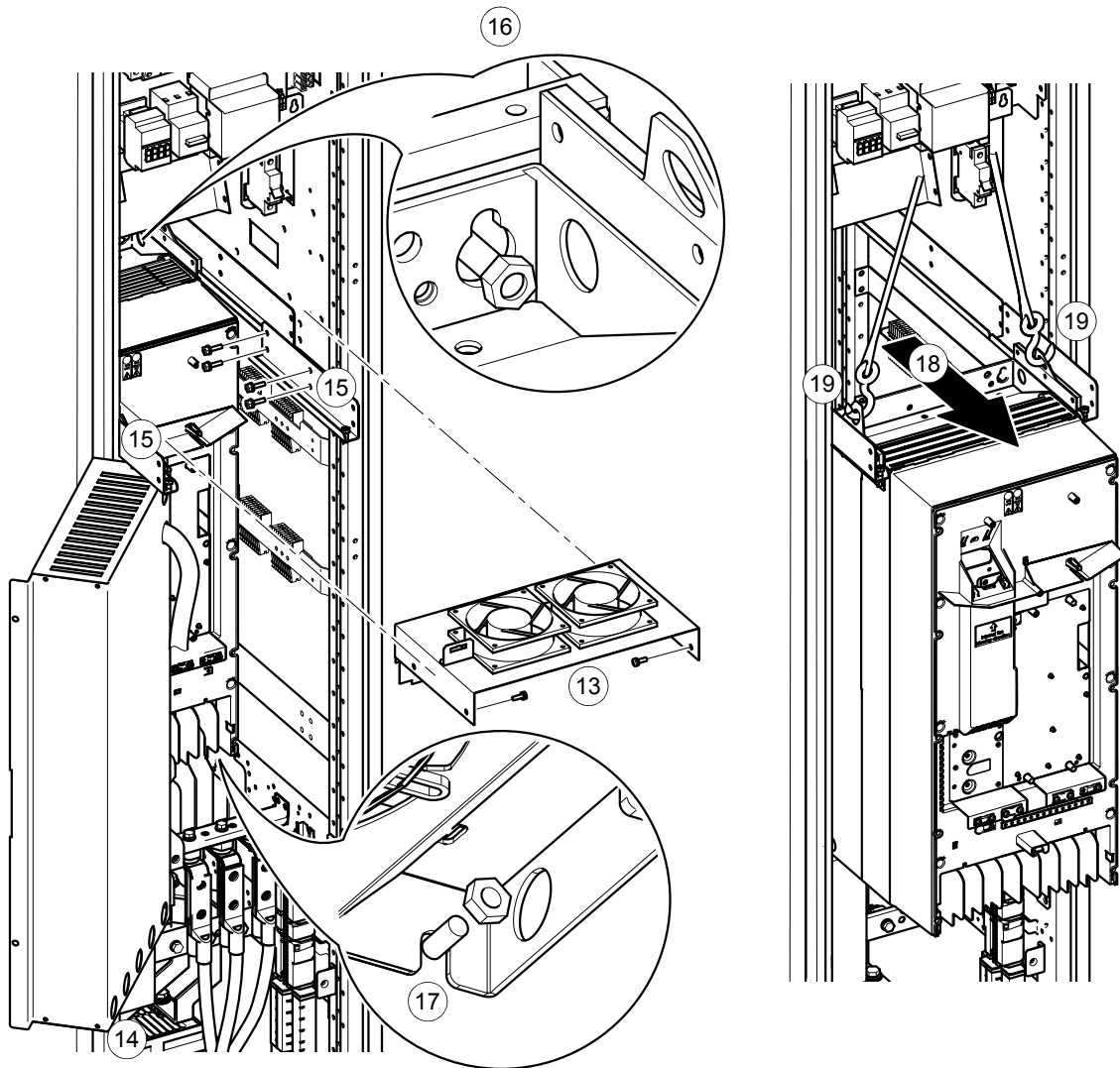

Replacing the drive module (frame R9)

Required in the replacing procedure: two persons, lifting chains, lifting device, a set of screw drivers and torque wrench with extension bar. A lifting device for ACS880-07 drive modules is available from ABB. For its installation and use, see *ACS880-07 lifting device user's manual* (3AUA0000131337 [English]).



WARNING! Obey the instructions in chapter [Safety instructions](#). If you ignore them, injury or death, or damage to the equipment can occur.



WARNING! Make sure that the cabinet is secured to the floor. If not, the cabinet can topple over when the heavy drive module is slid forward in front of the cabinet. This can cause physical injury or death and damage to the equipment.



1. Stop the drive and do the steps in section [Precautions before electrical work](#) on page 16 before you start the work.
2. Remove the shroud.
3. Remove the mounting plate above the shroud by loosening the mounting screws and lifting the plate up. For drives with options +G300, +G301, +G307 and +G313: Unplug the control cable terminals at the back side of the mounting plate.
4. For drives with options +L505 and +L506: Remove the Pt100 and thermistor relay mounting plate by loosening the two mounting screws and lifting the mounting plate up.
5. For drives with additional terminal block (option +L504): Disconnect the control cables from terminal block X504. Loosen the mounting screws of the terminal block and remove it.
6. Loosen the screws on the right-hand side of the swing-out frame and open the swing-out frame.
7. Unplug the control wire terminals at the right-hand side of the cabinet.
8. Unplug the control cable terminals from the control unit. Disconnect the control cables from the option modules on the control unit.
9. Unplug the cabinet fan power supply cables and remove the fan assembly above the drive module.
10. Unplug the wire terminals and remove mounting plate.
11. Disconnect the power cabling busbars from the drive module terminals.
12. Remove the slide extension rails (attached to the slide rails) by undoing the mounting screws. Install the extension rails at the end of the sliding rails.
13. Undo the upper mounting nuts of the drive module.
14. Undo the lower mounting nuts of the drive module.
15. Remove the two mounting screws of the top right mounting plate. Turn the plate to the horizontal position.

170 Maintenance

16. Slide the drive module towards the end of the sliding bars.
 17. Secure the drive module with chains from the lifting eyes.
 18. Lift the module out of the cabinet with the lifting device.
 19. Install the new module in reverse order.
-

R9

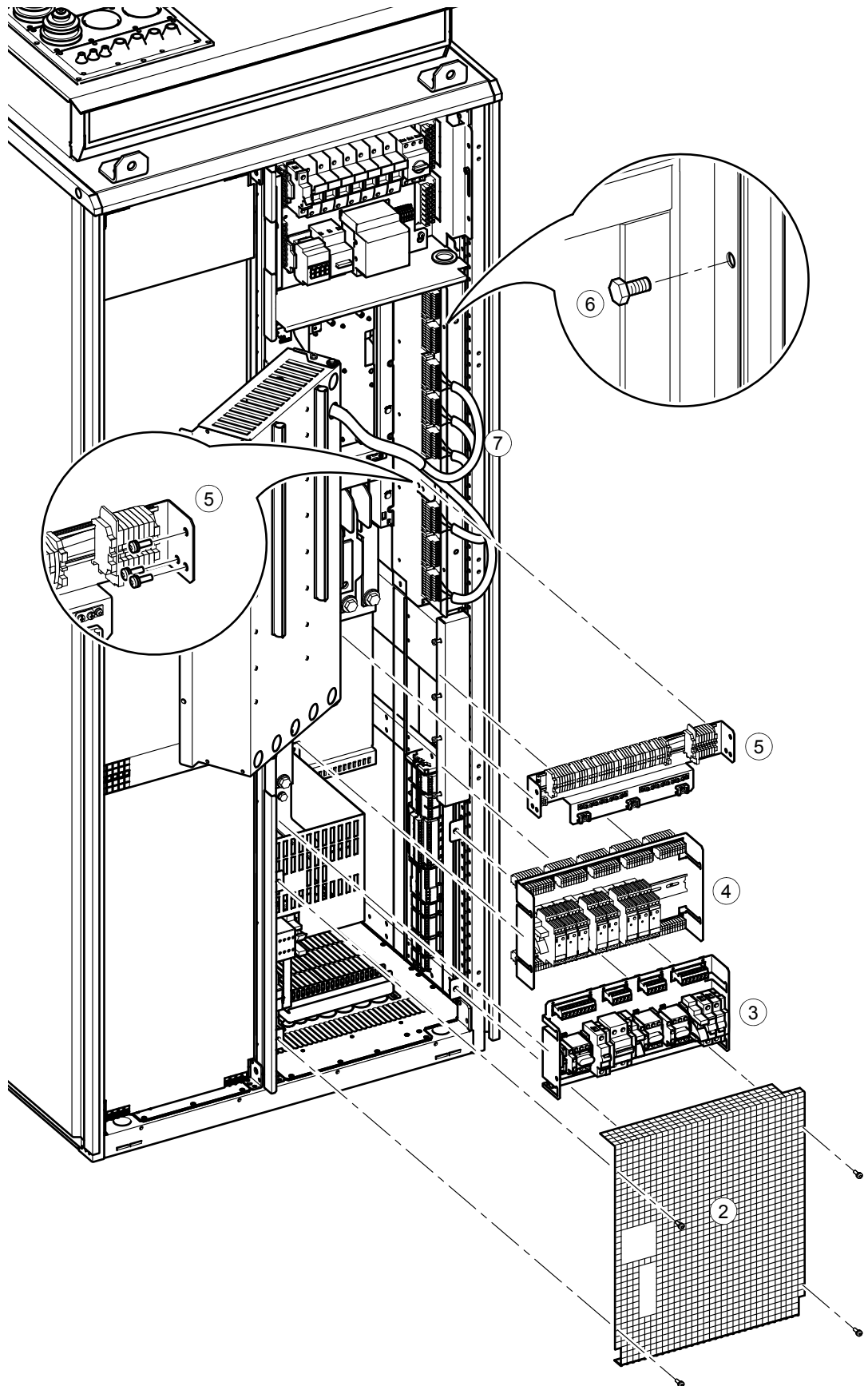

R9

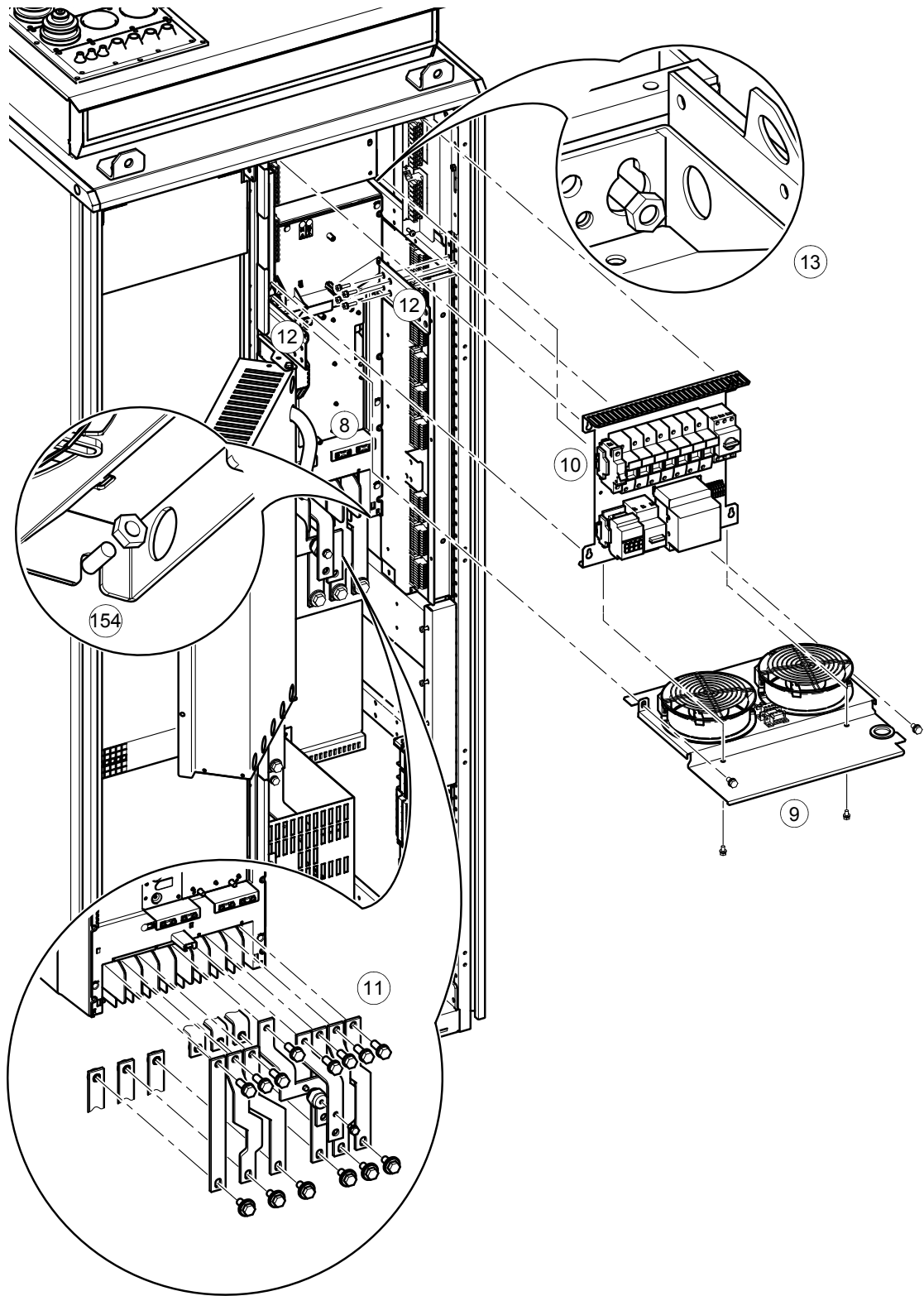

R9

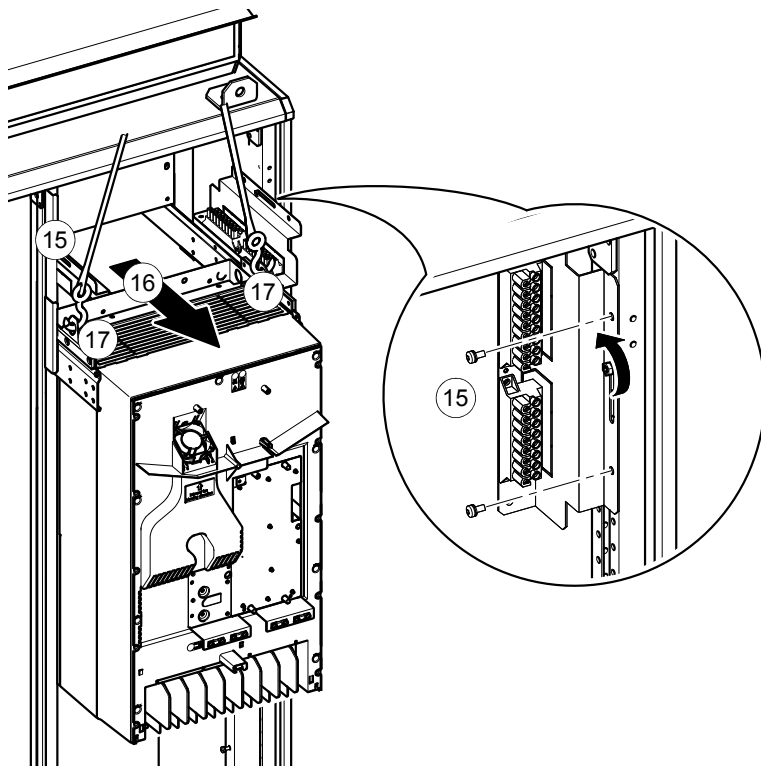

Replacing the drive module (frames R10 and R11)

This replacing procedure requires: two persons, installation ramp, a set of screw drivers and a torque wrench with an extension bar.

The drawings show frame R11. The details in frame R10 are slightly different.



WARNING! Obey the instructions in chapter [Safety instructions](#). If you ignore them, injury or death, or damage to the equipment can occur.

- Handle the drive module carefully:
 - Use safety shoes with a metal toe cap to avoid foot injury.
 - Lift the drive module only by the lifting lugs.
 - Make sure that the module does not topple over when you move it on the floor: Open the support legs by pressing each leg a little down (1, 2) and turning it aside. Whenever possible secure the module also with chains.
 - Do not tilt the drive module (A). It is **heavy** and its **center of gravity is high**. The module overturns from a sideways tilt of 5 degrees. Do not leave the module unattended on a sloping floor.

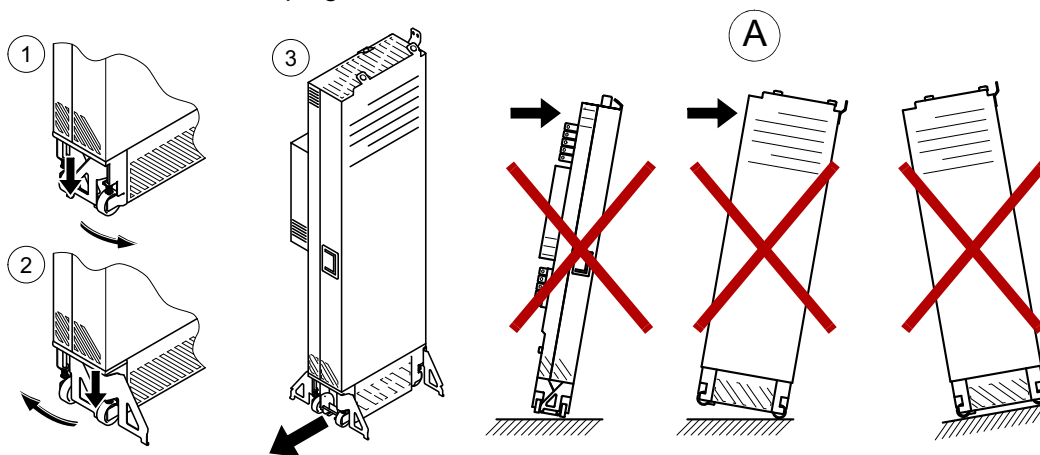

1. Stop the drive and do the steps in section [Precautions before electrical work](#) on page 16 before you start the work.
2. Unplug quick connector(s) at the right top corner of the control unit mounting plate.
3. Remove the control unit mounting plate.
4. Remove the shroud.
5. Remove the air baffle.
6. Remove the air baffle.
7. Remove the air baffle.
8. Disconnect the drive module busbars from the input cabling panel. Combi screw M12, 70 N·m (52 lbf·ft).
9. Disconnect the drive module busbars from the output cabling panel. Combi screw M12, 70 N·m (52 lbf·ft).
10. Undo the screws that fasten the drive module to the cabinet at the top and behind the front support legs.

11. Fasten the extraction ramp to the cabinet base with two screws.
 12. Attach the drive module lifting lugs to the cabinet lifting lug with chains.
 13. Pull the drive module carefully out of the cabinet preferably with help from another person.
 14. Install the new module in reverse order.
-

R10 and R11

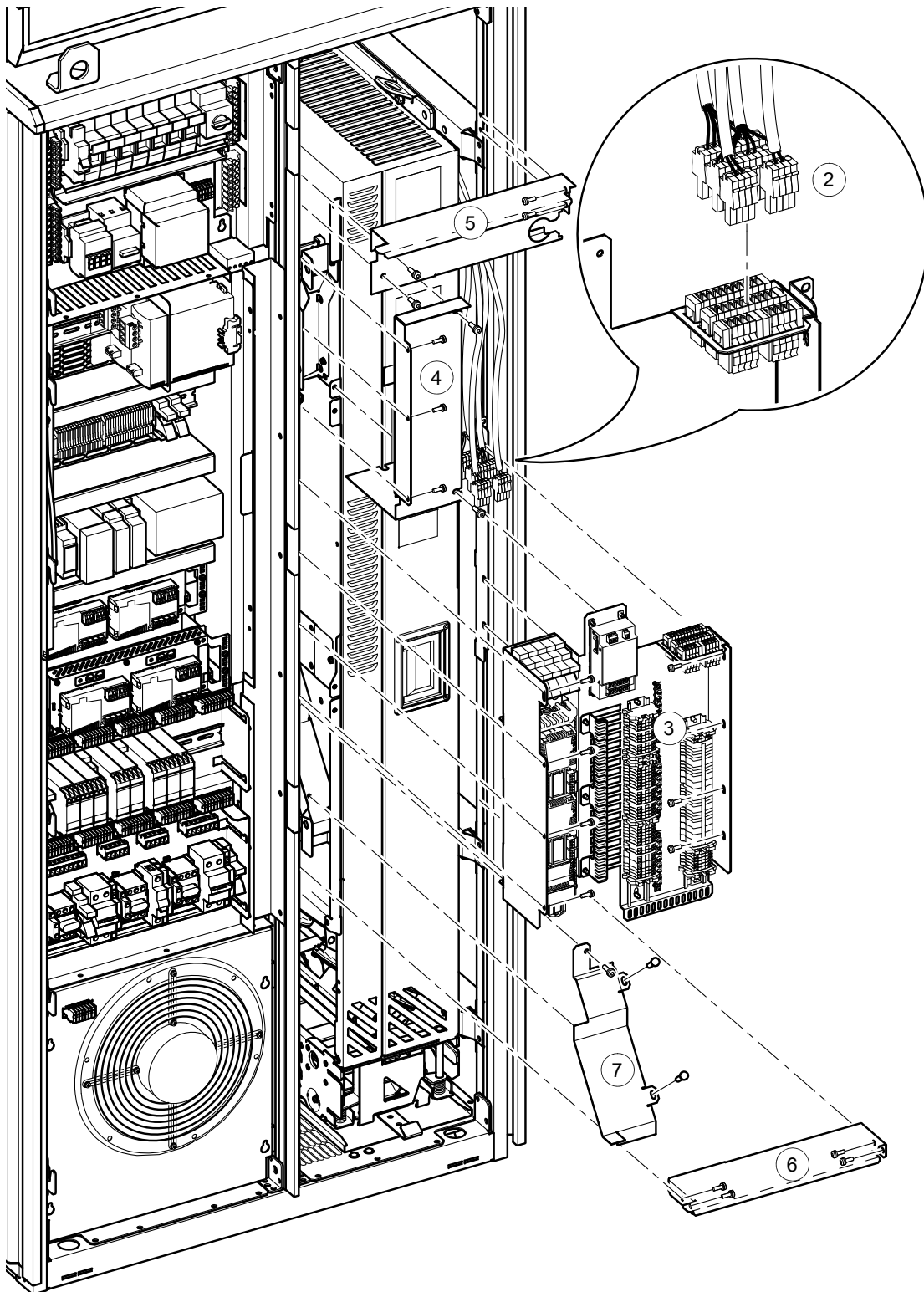

R10 and R11

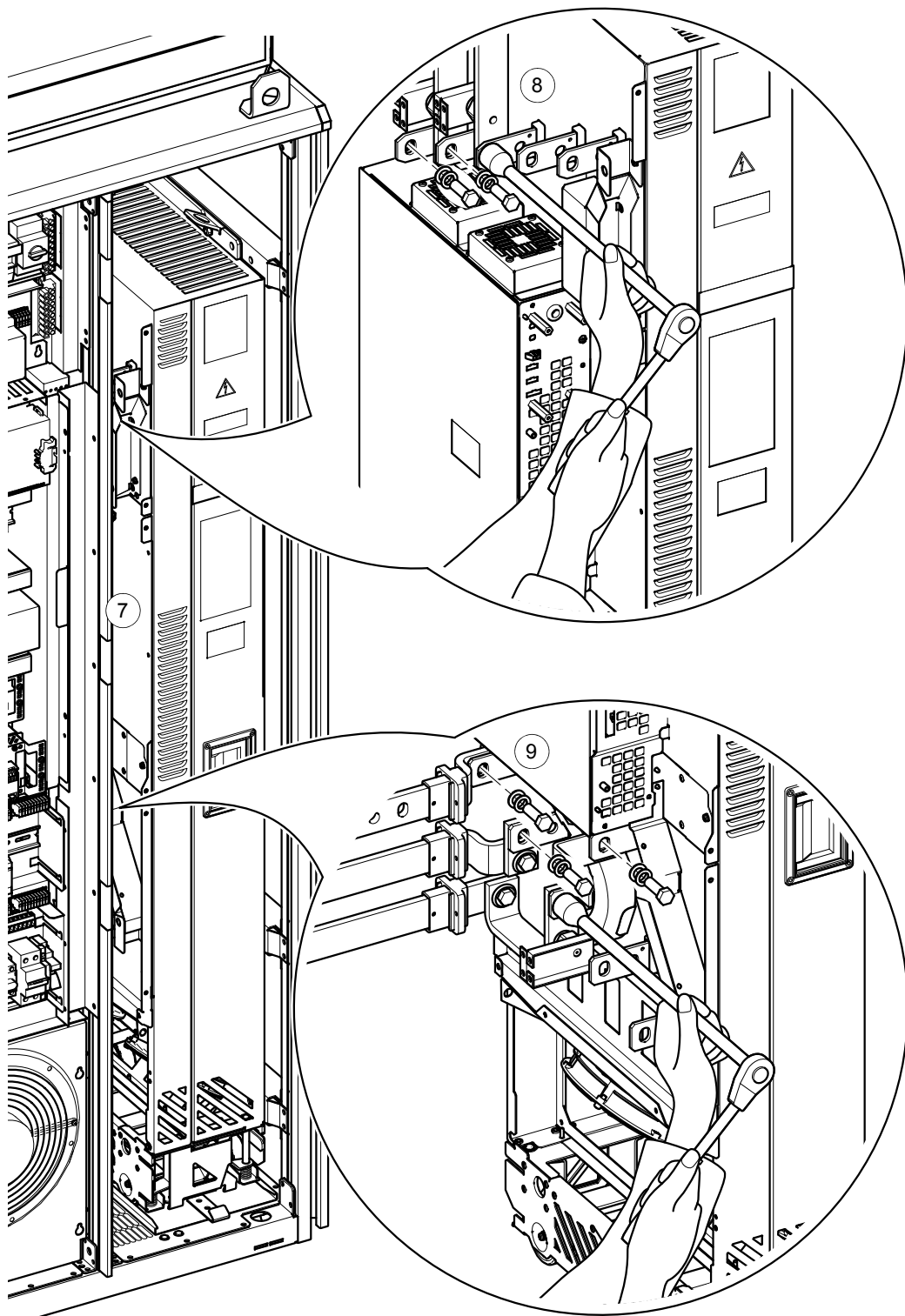

R10 and R11

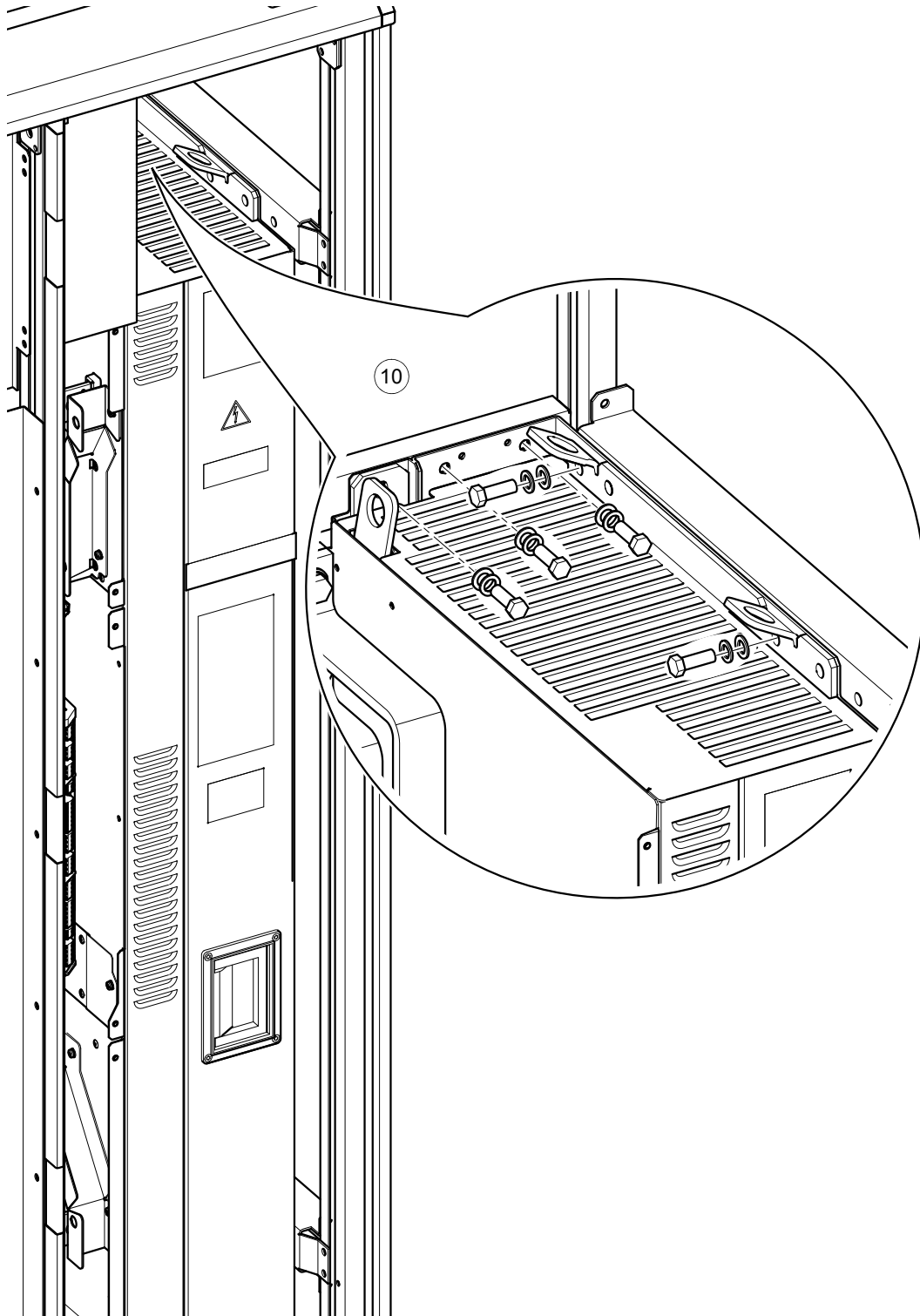

R10 and R11

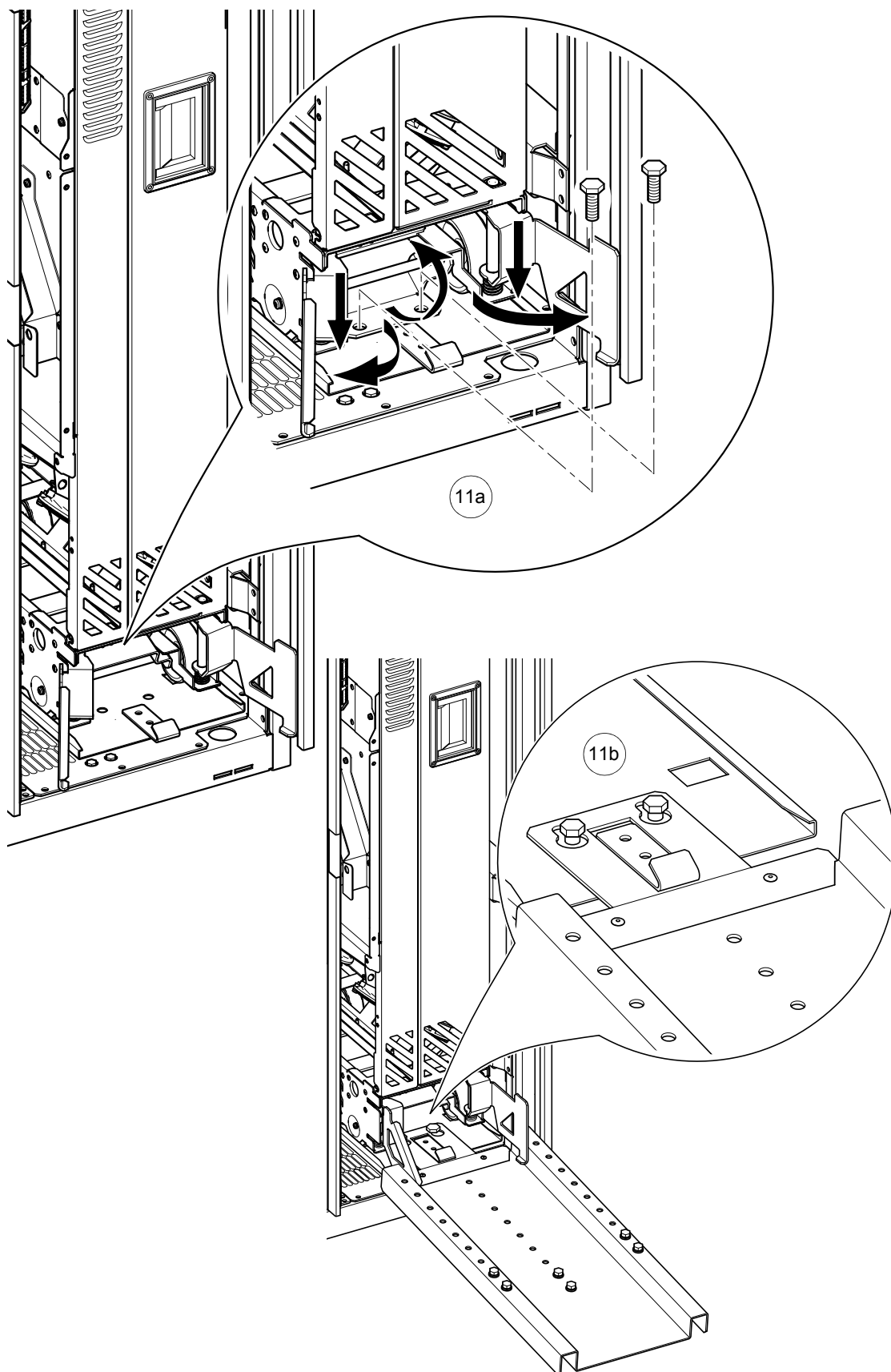

R10 and R11

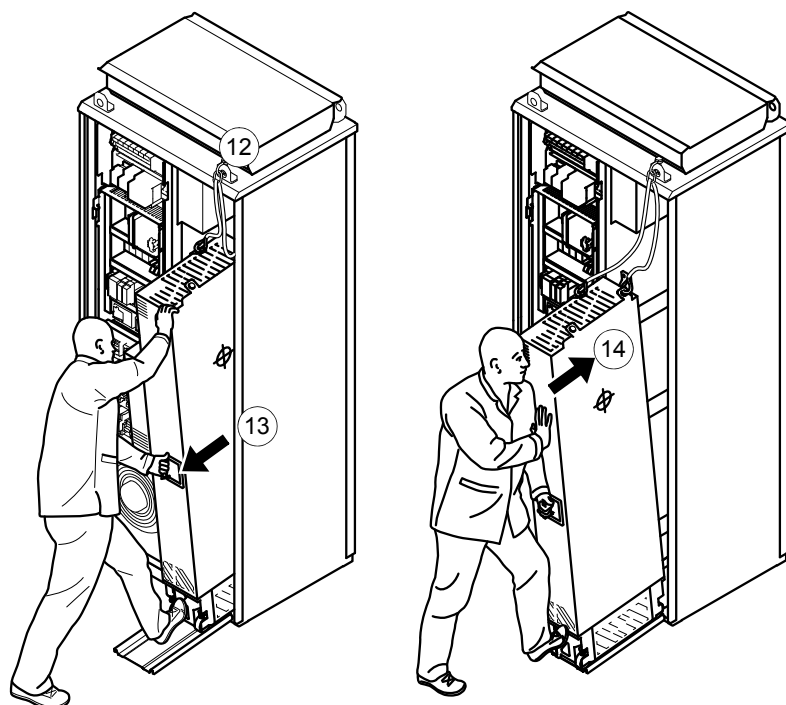

Capacitors

The drive intermediate circuit employs several electrolytic capacitors. Their lifespan depends on the operating time of the drive, loading and ambient temperature. Capacitor life can be prolonged by lowering the ambient temperature.

Capacitor failure is usually followed by damage to the unit and an input cable fuse failure, or a fault trip. Contact ABB if capacitor failure is suspected. Replacements are available from ABB. Do not use other than ABB specified spare parts.

■ Reforming the capacitors

Reform the capacitors if the drive has not been powered for a year or more. See page [49](#) for information on finding out the manufacturing date. For information on reforming the capacitors, see *Converter module capacitor reforming instructions* (3BFE64059629 [English]).

Replacing the control panel battery

The battery is housed on the rear of the control panel. Replace with a new CR 2032 battery. Dispose the old battery according to local disposal rules or applicable laws.



Replacing the control unit battery

1. Stop the drive and do the steps in section [Precautions before electrical work](#) on page [16](#) before you start the work.

To replace the control unit battery:

1. Remove the M4x8 (T20) screws at the ends of the control unit.
2. To see the battery, remove the XD2D terminal block.
3. Carefully lift the edge of the control unit cover on the side with the I/O terminal blocks.
4. Carefully pull the battery out of the battery holder.
5. Carefully put a new CR2032 battery into the battery holder.
6. Close the control unit cover.
7. Tighten the M4x8 (T20) screws.
8. Install the XD2D terminal block.

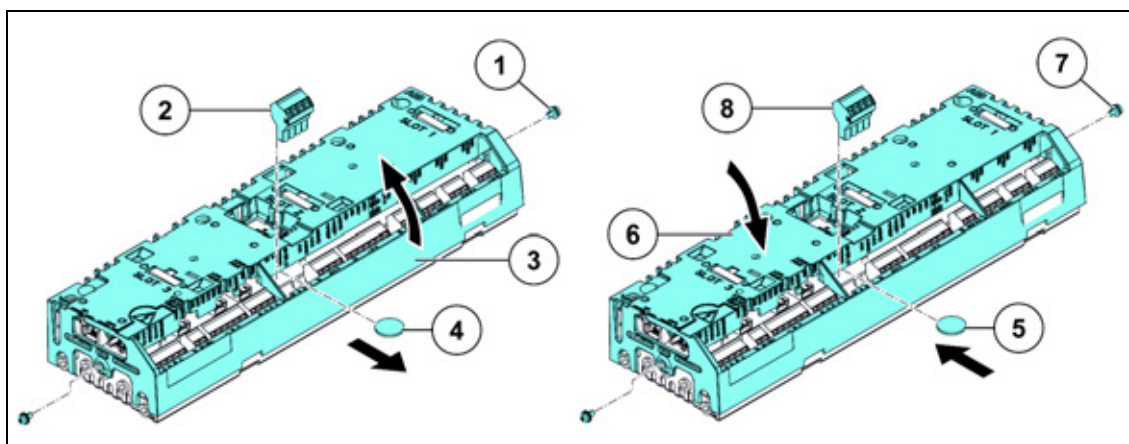

Memory unit

When a drive is replaced, the parameter settings can be retained by transferring the memory unit from the defective drive to the new drive. The memory unit is located on the control unit, see page [126](#) or [136](#).

■ Transferring the memory unit



WARNING! Obey the instructions in chapter [Safety instructions](#). If you ignore them, injury or death, or damage to the equipment can occur.

1. Stop the drive and do the steps in section [Precautions before electrical work](#) on page [16](#) before you start the work.
2. Undo the memory unit mounting screw and take the memory unit out. Replace the unit in reverse order. **Note:** For frames R6 to R9, there is a spare screw next to the memory unit slot.

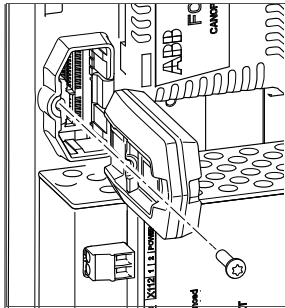

R6...R9

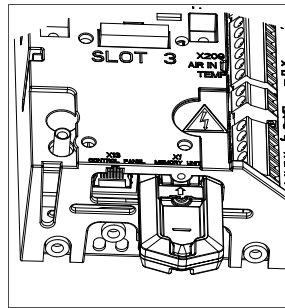

R10, R11

13

Technical data

Contents of this chapter

This chapter contains the technical specifications of the drive, for example, the ratings, sizes and technical requirements, provisions for fulfilling the requirements for CE and other markings.

Ratings

The nominal ratings for the drives with 50 Hz and 60 Hz supply are given below. The symbols are described below the table.

IEC RATINGS										
Drive type ACS880-07-	Frame size	Input rating	Output ratings							
			No-overload use				Light-overload use		Heavy-duty use	
			I_{1N}	I_{max}	I_N	P_N	S_N	I_{Ld}	P_{Ld}	I_{Hd}
A	A	A	kW	kVA	A	kW	A	kW		
$U_N = 400\text{ V}$										
0105A-3	R6	105	148	105	55	73	100	55	87	45
0145A-3	R6	145	178	145	75	100	138	75	105	55
0169A-3	R7	169	247	169	90	117	161	90	145	75
0206A-3	R7	206	287	206	110	143	196	110	169	90
0246A-3	R8	246	350	246	132	170	234	132	206	110
0293A-3	R8	293	418	293	160	203	278	160	246*	132
0363A-3	R9	363	498	363	200	251	345	200	293	160
0430A-3	R9	430 ¹⁾	545	430 ¹⁾	250	298	400	200	363**	200
0505A-3	R10	505	560	505	250	350	485	250	361	200

IEC RATINGS											
Drive type ACS880-07-	Frame size	Input rating	Output ratings								
			No-overload use				Light-overload use		Heavy-duty use		
			I_{1N}	I_{max}	I_N	P_N	S_N	I_{Ld}	P_{Ld}	I_{Hd}	P_{Hd}
			A	A	A	kW	kVA	A	kW	A	kW
0585A-3	R10	585	730	585	315	405	575	315	429	250	
0650A-3	R10	650	730	650	355	450	634	355	477	250	
0725A-3	R11	725	1020	725	400	502	715	400	566	315	
0820A-3	R11	820	1020	820	450	568	810	450	625	355	
0880A-3	R11	880	1100	880	500	610	865	500	725 ***	400	
1) At 25 °C (77 °F) ambient temperature the current is 451 A.											
$U_N = 500 V$											
0096A-5	R6	96	148	96	55	83	91	55	77	45	
0124A-5	R6	124	178	124	75	107	118	75	96	55	
0156A-5	R7	156	247	156	90	135	148	90	124	75	
0180A-5	R7	180	287	180	110	156	171	110	156	90	
0240A-5	R8	240	350	240	132	208	228	132	180	110	
0260A-5	R8	260	418	260	160	225	247	160	240*	132	
0361A-5	R9	361	542	361	200	313	343	200	302	200	
0414A-5	R9	414	542	414	250	359	393	250	361**	200	
0460A-5	R10	460	560	460	315	398	450	315	330	200	
0503A-5	R10	503	560	503	355	436	483	315	361	250	
0583A-5	R10	583	730	583	400	505	573	400	414	250	
0635A-5	R10	635	730	635	450	550	623	450	477	315	
0715A-5	R11	715	850	715	500	619	705	500	566	400	
0820A-5	R11	820	1020	820	560	710	807	560	625	450	
0880A-5	R11	880	1100	880	630	762	857	560	697*	500	
$U_N = 690 V$											
0061A-7	R6	61	104	61	55	73	58	55	49	45	
0084A-7	R6	84	124	84	75	100	80	75	61	55	
0098A-7	R7	98	168	98	90	117	93	90	84	75	
0119A-7	R7	119	198	119	110	142	113	110	98	90	
0142A-7	R8	142	250	142	132	170	135	132	119	110	
0174A-7	R8	174	274	174	160	208	165	160	142	132	
0210A-7	R9	210	384	210	200	251	200	200	174	160	
0271A-7	R9	271	411	271	250	324	257	250	210	200	
0330A-7	R10	330	480	330	315	394	320	315	255	250	
0370A-7	R10	370	520	370	355	442	360	355	325	315	
0430A-7	R10	430	520	430	400	514	420	400	360****	355	
0470A-7	R11	470	655	470	450	508	455	450	415	400	
0522A-7	R11	522	655	522	500	562	505	500	455	450	
0590A-7	R11	590	800	590	560	624	571	560	505	500	
0650A-7	R11	650	820	650	630	705	630	630	571****	560	
0721A-7	R11	721	820	721	710	862	705	630	571****	560	

NEMA RATINGS													
Drive type ACS880-07-	Frame size	Input rating	Max. current	App. power	Output ratings								
					Light-overload use			Heavy-duty use					
					I_{1N}	I_{max}	S_N	I_{Ld}	P_{Ld}		I_{Hd}	P_{Hd}	
					A	A	kVA	A	kW	hp	A	kW	hp
$U_N = 460\text{ V}$													
0096A-5	R6	96	148	83	96	55	75	77	45	60			
0124A-5	R6	124	178	107	124	75	100	96	55	75			
0156A-5	R7	156	247	135	156	90	125	124	75	100			
0180A-5	R7	180	287	156	180	110	150	156	90	125			
0240A-5	R8	240	350	208	240	132	200	180	110	150			
0302A-5	R9	375	498	325	302	200	250	260	132	200			
0361A-5	R9	361	542	313	361	200	300	302	200	250			
0414A-5	R9	414	542	359	393 ²⁾	250	350	361**	200	300			
0503A-5	R10	503	560	398	483	315	400	361	250	300			
0583A-5	R10	583	730	436	573	400	450	414	250	350			
0635A-5	R10	635	730	505	623	450	500	477	315	400			
0715A-5	R11	715	850	550	705	500	600	566	400	450			
0820A-5	R11	820	1020	710	807	560	700	625	450	500			
0880A-5	R11	860	1100	762	857	560	700	697****	500	600			
2) At 30 °C (86 °F) ambient temperature the current is 414 A.													
$U_N = 600\text{ V}$													
0061A-7	R6	61	104	73	62	45	60	52	37	50			
0084A-7	R6	84	124	100	77	55	75	62	45	60			
0098A-7	R7	98	168	117	99	75	100	77	55	75			
0119A-7	R7	119	198	142	125	90	125	99	75	100			
0142A-7	R8	142	250	170	144	110	150	125	90	125			
0174A-7 (See note 3 below)	R8	174	274	208	192*	132	200	144	110	150			
0210A-7	R9	210	384	251	242	160	250	192	132	200			
0271A-7 (See note 4 below)	R9	271	411	324	271	200	250	242	160	250			
0330A-7	R10	330	480	394	320	320	300	255	250	250			
0370A-7	R10	370	520	442	360	360	350	325	300	300			
0430A-7	R10	430	520	514	420	400	450	360****	355	350			
0470A-7	R11	470	655	508	455	455	450	415	450	450			
0522A-7	R11	522	655	562	505	505	500	455	450	450			
0590A-7	R11	590	800	624	571	571	600	505	500	500			
0650A-7	R11	650	820	705	630	630	700	571	600	600			
0721A-7	R11	721	820	762	705	560	700	571****	500	600			

3AXD1000044776

■ Definitions

U_N	Nominal voltage
I_{1N}	Nominal rms input current

I_N	Nominal output current (available continuously with no over-loading)
S_N	Apparent power (no overload)
P_N	Typical motor power in no-overload use
I_{Ld}	Continuous rms output current allowing 10% overload for 1 minute every 5 minutes.
P_{Ld}	Typical motor power in light-overload use
I_{max}	Maximum output current. Available for 10 seconds at start, then as long as allowed by drive temperature.
I_{Hd}	Continuous rms output current allowing 50% overload for 1 minute every 5 minutes. * Continuous rms output current allowing 30% overload for 1 minute every 5 minutes. ** Continuous rms output current allowing 25% overload for 1 minute every 5 minutes. *** Continuous rms output current allowing 40% overload for 1 minute every 5 minutes. **** Continuous rms output current allowing 44% overload for 1 minute every 5 minutes.
P_{Hd}	Typical motor power in heavy-duty use

Note 1: The ratings apply at an ambient temperature of 40 °C (104 °F).

Note 2: To achieve the rated motor power given in the table, the rated current of the drive must be higher than or equal to the rated motor current.

The DriveSize dimensioning tool available from ABB is recommended for selecting the drive, motor and gear combination.

Note 3 – ACS880-07-0174A-7 amp rating: The drive can deliver 192 A continuously with no overload.

Note 4 – ACS880-07-0271A-7 power rating: The power rating is as per NEC Table 42.1. However, the drive can be used for a typical 4-pole motor rated to 300 hp meeting NEMA MG 1 Table 12-11 minimum efficiency standard (EPAAct efficiency electrical motors) if motor full load current is not more than 271 A.

Derating

Ambient temperature derating

In the temperature range +40...50 °C (+104...122 °F), the rated output current is derated by 1% for every added 1 °C (1.8 °F). The output current can be calculated by multiplying the current given in the rating table by the derating factor (k):

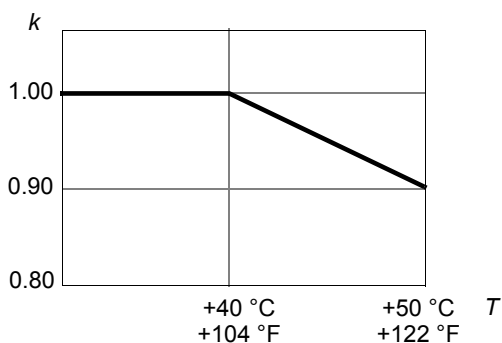

■ Altitude derating

At altitudes from 1000 to 4000 m (3300 to 13123 ft) above sea level, the derating is 1% for every 100 m (328 ft). If ambient temperature is below +40 °C (+104 °F), the derating can be reduced by 1.5% for every 1 °C reduction in temperature. For a more accurate derating, use the DriveSize PC tool. A few altitude derating curves are shown below.

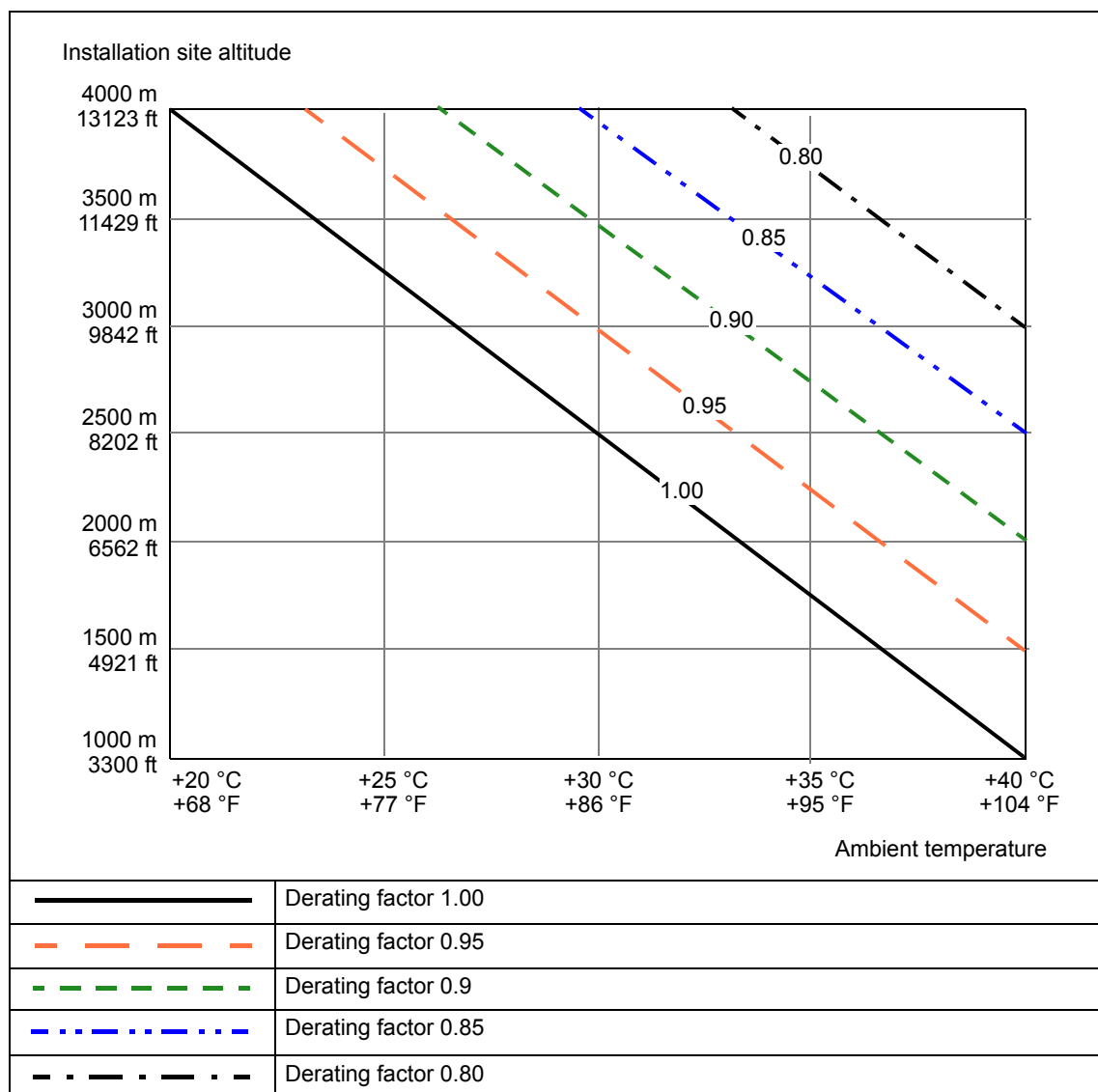

■ Deratings for special settings in the drive control program

Enabling special settings in the drive control program can require output current derating.

Ex motor, sine filter, low noise

Table below gives the deratings for these cases:

- drive is used with an ABB motor for explosive atmospheres (Ex) and **EX motor** in **Parameter 95.15 Special HW settings** is enabled
- sine filter given in the selection table on page 222 is used and **ABB sine filter** in **Parameter 95.15 Special HW settings** is enabled
- **Low noise optimization** is selected in **Parameter 97.09 Switching freq mode**.

For non-ABB Ex motors, contact ABB.

Drive module type ACS880-04-	Output ratings for special settings											
	Ex motor (ABB Ex motor)				ABB sine filter				Low noise mode			
	Nominal use		Light-duty use	Heavy-duty use	Nominal use		Light-duty use	Heavy-duty use	Nominal use		Light-duty use	Heavy-duty use
	I_N	P_N	I_{Ld}	I_{Hd}	I_N	P_N	I_{Ld}	I_{Hd}	I_N	P_N	I_{Ld}	I_{Hd}
A	kW	A	A	A	kW	A	A	A	kW	A	A	
$U_N = 400\text{ V}$												
0105A-3	97	45	92	87	91	45	86	77	86		82	67
0145A-3	134	55	127	97	126	55	120	91	118		112	86
0169A-3	160	75	152	134	152	75	144	126	146		139	118
0206A-3	195	90	185	160	186	90	177	152	178		169	146
0246A-3	225	110	214	195	209	110	199	186	194		184	178
0293A-3	269	132	256	225*	249	132	237	209*	236		224	194*
0363A-3	325	160	309	269	296	160	281	249	274		260	236
0430A-3	385	200	366	325**	352	160	334	296**	325		309	274**
0505A-3	479	250	459	345	470	250	450	340	390	200	370	290
0585A-3	551	250	389	287	540	250	518	383	437	250	419	311
0650A-3	613	315	432	319	600	315	576	425	485	250	466	346
0725A-3	667	355	471	351	647	355	628	468	519	250	496	390
0820A-3	753	400	534	388	731	400	712	517	587	315	562	431
0880A-3	809	450	570	450	785	450	760	600	630	355	600	500*
$U_N = 500\text{ V}$												
0096A-5	88	45	84	77	82	45	78	61	72		68	46
0124A-5	115	55	109	88	104	55	99	82	93		88	72
0156A-5	147	75	140	115	140	75	133	104	133		126	93
0180A-5	170	90	162	147	161	90	153	140	153		145	133
0240A-5	220	110	209	170	204	110	194	161	191		181	153
0260A-5	238	132	226	220*	221	110	210	204*	206		196	191*
0302A-5	270	160	257	238	-	-	-	-	206		196	191
0361A-5	322	200	306	270	289	160	275	242	258		245	206
0414A-5	370	200	352	322**	332	200	315	289**	296		281	258**
0460A-5	437	250	427	316	430	250	419	311	357	250	345	265
0503A-5	478	315	458	345	470	315	450	340	390	250	370	290
0583A-5	531	355	509	364	514	355	487	347	400	250	380	298
0635A-5	579	400	553	419	560	400	530	400	410	250	392	298
0715A-5	657	450	641	522	637	450	620	507	462	315	428	362
0820A-5	753	500	734	576	730	500	710	560	530	355	490	400
0880A-5	768	500	747	594	730	500	710	560	550	400	510	410
$U_N = 690\text{ V}$												
0061A-7	61	55	58	49	49	45	47	46	49	45	47	46
0084A-7	84	75	80	61	68	55	65	49	68	55	65	49
0098A-7	98	90	93	84	83	75	79	68	83	75	79	68
0119A-7	119	110	113	98	101	90	96	83	101	90	96	83
0142A-7	126	110	120	119	112	90	106	90	101	90	96	84
0174A-7	154	132	146	126	137	110	130	112	122	110	116	101

Drive module type ACS880-04-	Output ratings for special settings											
	Ex motor (ABB Ex motor)				ABB sine filter				Low noise mode			
	Nominal use		Light-duty use	Heavy-duty use	Nominal use		Light-duty use	Heavy-duty use	Nominal use		Light-duty use	Heavy-duty use
	I_N	P_N	I_{Ld}	I_{Hd}	I_N	P_N	I_{Ld}	I_{Hd}	I_N	P_N	I_{Ld}	I_{Hd}
A	kW	A	A	A	kW	A	A	A	kW	A	A	
0210A-7	184	160	175	154	161	132	153	137	138	132	131	122
0271A-7	238	200	226	184	207	160	197	161	178	160	169	138
0330A-7	310	250	300	217	303	250	293	204	232	200	222	157
0370A-7	348	315	338	276	340	315	330	260	260	250	250	200
0430A-7	378	355	368	315	360	355	350	300*	290	250	280	236*
0470A-7	388	355	376	335	360	355	349	308	270	250	261	238
0522A-7	431	400	417	370	400	355	388	342	300	250	290	262
0590A-7	485	450	470	449	450	400	436	385	340	315	330	300
0650A-7	575	500	555	480	550	500	530	450*	450	400	430	350*
0721A-7	593	500	574	480	550	500	530	450*	450	400	430	350*

3AXD0000588487,

U_N	Nominal voltage of the drive
I_N	Continuous rms output current. No overload capability at 40 °C (104 °F)
P_N	Typical motor power in no-overload use.
I_{Ld}	Continuous rms output current allowing 10% overload for 1 minute every 5 minutes
I_{Hd}	Continuous rms output current allowing 50% overload for 1 minute every 5 minutes * Continuous rms output current allowing 30% overload for 1 minute every 5 minutes. ** Continuous rms output current allowing 25% overload for 1 minute every 5 minutes.
*	Continuous rms output current allowing 44% overload for 1 minute every 5 minutes
The ratings apply at an ambient temperature of 40 °C (104 °F).	

High speed mode

Selection **High speed mode** of parameter **95.15 Special HW settings** improves control performance at high output frequencies. We recommend it to be selected with output frequency of 120 Hz and above.

This table gives the drive module ratings for 120 Hz output frequency and the maximum output frequency for the drive ratings when **High speed mode** in parameter **95.15 Special HW settings** is enabled: With output frequencies smaller than this recommended maximum output frequency, the current derating is less than the values given in the table. Contact ABB for operation above the recommended maximum output frequency or for the output current derating with output frequencies above 120 Hz and below the maximum output frequency.

Drive module type ACS880-04-	Deratings with selection High speed mode of parameter 95.15 Special HW settings									
	120 Hz output frequency					Maximum output frequency				
		Nominal use		Light-duty use	Heavy-duty use		Nominal use		Light-duty use	Heavy-duty use
	f	I_N	P_N	I_{Ld}	I_{Hd}	f_{max}	I_N	P_N	I_{Ld}	I_{Hd}
	Hz	A	kW	A	A	Hz	A	kW	A	A
$U_N = 400\text{ V}$										
0105A-3	120					500	77		73	67
0145A-3	120					500	106		101	77
0169A-3	120					500	135		128	106
0206A-3	120					500	165		157	135
0246A-3	120					500	170		162	143
0293A-3	120					500	202		192	170*
0363A-3	120					500	236		224	202
0430A-3	120					500	280		266	236**
0505A-3	120	505	250	485	361	500	390	200	370	290
0585A-3	120	585	315	575	429	500	437	250	419	311
0650A-3	120	650	355	634	477	500	485	250	466	346
0725A-3	120	725	400	715	566	500	519	250	496	390
0820A-3	120	820	450	810	625	500	587	315	562	431
0880A-3	120	880	500	865	725*	500	630	355	600	500*
$U_N = 500\text{ V}$										
0096A-5	120					500	58		55	46
0124A-5	120					500	74		70	58
0156A-5	120					500	122		116	74
0180A-5	120					500	140		133	122
0240A-5	120					500	168		160	140
0260A-5	120					500	182		173	168*
0302A-5	120					500	182		173	168*
0361A-5	120					500	206		196	182
0414A-5	120					500	236		224	206**
0460A-5	120	460	315	450	330	500	357	250	345	265
0503A-5	120	503	355	483	361	500	390	250	370	290
0583A-5	120	583	400	573	414	500	400	250	380	298
0635A-5	120	635	450	623	477	500	410	250	392	298

Drive module type ACS880-04-	Deratings with selection High speed mode of parameter 95.15 Special HW settings									
	120 Hz output frequency					Maximum output frequency				
		Nominal use		Light-duty use	Heavy-duty use		Nominal use		Light-duty use	Heavy-duty use
	f	I_N	P_N	I_{Ld}	I_{Hd}	f_{max}	I_N	P_N	I_{Ld}	I_{Hd}
Hz	A	kW	A	A	Hz	A	kW	A	A	
0715A-5	120	715	500	705	566	500	462	315	428	362
0820A-5	120	820	560	807	625	500	530	355	490	400
0880A-5	120	880	630	857	697*	500	550	400	510	410
$U_N = 690$ V										
0061A-7	120					500	44		42	40
0084A-7	120					500	53		50	44
0098A-7	120					500	68		65	53
0119A-7	120					500	83		79	68
0142A-7	120					500	83		79	72
0174A-7	120					500	96		91	83
0210A-7	120					500	101		96	83
0271A-7	120					500	130		124	101
0330A-7	120	330	315	320	255	375	232	200	222	157
0370A-7	120	370	355	360	325	375	260	250	250	200
0430A-7	120	430	400	420	360*	375	290	250	280	236*
0470A-7	120	425	400	415	360		287	247	277	233
0522A-7	120	470	450	455	415	375	270	250	261	238
0590A-7	120	522	500	505	455	375	300	250	290	262
0650A-7	120	590	560	571	505	375	340	315	330	300
0721A-7	120	650	630	630	571*	375	450	400	430	350*

3AXD0000588487

f	Output frequency
f_{max}	Maximum output frequency with High speed mode
U_N	Nominal voltage of the drive
I_N	Continuous rms output current. No overload capability at 40 °C (104 °F)
P_N	Typical motor power in no-overload use.
I_{Ld}	Continuous rms output current allowing 10% overload for 1 minute every 5 minutes
P_{Ld}	Typical motor power for light-overload use.
I_{Hd}	Continuous rms output current allowing 50% overload for 1 minute every 5 minutes * Continuous rms output current allowing 40% overload for 1 minute every 5 minutes ** Continuous rms output current allowing 25% overload for 1 minute every 5 minutes
The ratings apply at an ambient temperature of 40 °C (104 °F).	

Fuses (IEC)

The drive is equipped with aR fuses listed below.

Drive type ACS880-07-	Input current (A)	Ultrarapid (aR) fuses (one fuse per phase)						
		A	A ² s	V	Manufacturer	Type	Type with option +F289	Size
$U_N = 400\text{ V}$								
0105A-3	105	160	8250	690	Bussmann	170M3814D	170M3414	1
0145A-3	145	250	31000	690	Bussmann	170M3816D	170M3416	1
0169A-3	169	250	31000	690	Bussmann	170M3816D	170M3416	1
0206A-3	206	315	52000	690	Bussmann	170M3817D	170M4410	1
0246A-3	246	400	79000	690	Bussmann	170M5808D	170M5408	2
0293A-3	293	500	155000	690	Bussmann	170M5810D	170M5410	2
0363A-3	363	630	210000	690	Bussmann	170M6410	170M6410	3
0430A-3	430	700	300000	690	Bussmann	170M6411	170M6411	3
0505A-3	505	800	465000	690	Bussmann	170M6412	170M6412	3
0585A-3	585	900	670000	690	Bussmann	170M6413	170M6413	3
0650A-3	650	1000	945000	690	Bussmann	170M6414	170M6414	3
0725A-3	725	1250	1950000	690	Bussmann	170M6416	170M6416	3
0820A-3	820	1250	1950000	690	Bussmann	170M6416	170M6416	3
0880A-3	880	1400	2450000	690	Bussmann	170M6417	170M6417	3
$U_N = 500\text{ V}$								
0096A-5	96	160	8250	690	Bussmann	170M3814D	170M3414	1
0124A-5	124	250	31000	690	Bussmann	170M3816D	170M3416	1
0156A-5	156	250	31000	690	Bussmann	170M3816D	170M3416	1
0180A-5	180	315	52000	690	Bussmann	170M3817D	170M4410	1
0240A-5	240	400	79000	690	Bussmann	170M5808D	170M5408	2
0260A-5	260	500	155000	690	Bussmann	170M5810D	170M5410	2
0361A-5	361	630	210000	690	Bussmann	170M6410	170M6410	3
0414A-5	414	700	300000	690	Bussmann	170M6411	170M6411	3
0460A-5	460	700	300000	690	Bussmann	170M6411	170M6411	3
0503A-5	503	800	465000	690	Bussmann	170M6412	170M6412	3
0583A-5	583	900	670000	690	Bussmann	170M6413	170M6413	3
0635A-5	635	1000	945000	690	Bussmann	170M6414	170M6414	3
0715A-5	715	1250	1950000	690	Bussmann	170M6416	170M6416	3
0820A-5	820	1250	1950000	690	Bussmann	170M6416	170M6416	3
0880A-5	880	1400	2450000	690	Bussmann	170M6417	170M6417	3
$U_N = 690\text{ V}$								
0061A-7	61	100	2600	690	Bussmann	170M3812D	170M3412	1*
0084A-7	84	160	8250	690	Bussmann	170M3814D	170M3414	1
0098A-7	98	160	8250	690	Bussmann	170M3814D	170M3414	1
0119A-7	119	250	31000	690	Bussmann	170M3816D	170M3416	1
0142A-7	142	250	31000	690	Bussmann	170M3816D	170M3416	1
0174A-7	174	315	52000	690	Bussmann	170M3817D	170M4410	1
0210A-7	210	315	42000	690	Bussmann	170M4410	170M4410	2
0271A-7	271	500	145000	690	Bussmann	170M5410	170M5410	2
0330A-7	330	630	210000	690	Bussmann	170M6410	170M6410	3

Drive type ACS880-07-	Input current (A)	Ultrarapid (aR) fuses (one fuse per phase)						
		A	A ² s	V	Manufacturer	Type	Type with option +F289	Size
0370A-7	370	630	210000	690	Bussmann	170M6410	170M6410	3
0430A-7	430	700	300000	690	Bussmann	170M6411	170M6411	3
0470A-7	470	800	465000	690	Bussmann	170M6412	170M6412	3
0522A-7	522	800	465000	690	Bussmann	170M6412	170M6412	3
0590A-7	590	900	670000	690	Bussmann	170M6413	170M6413	3
0650A-7	650	1000	945000	690	Bussmann	170M6414	170M6414	3
0721A-7	721	1250	1950000	690	Bussmann	170M6416	170M6416	3

Note 1: See also [Implementing thermal overload and short-circuit protection](#) on page 84.

Note 2: Fuses with higher current rating than the recommended ones must not be used. Fuses with lower current rating can be used.

Note 3: Fuses from other manufacturers can be used if they meet the ratings and the melting curve of the fuse does not exceed the melting curve of the fuse mentioned in the table.

Fuses (UL)

The drive is equipped for branch circuit protection per NEC with standard fuses listed below. The fuses restrict drive damage and prevent damage to adjoining equipment in case of a short-circuit inside the drive. **Check that the operating time of the fuse is below 0.5 seconds for frame size R6 and is below 0.1 seconds for frames R7 through R11.** The operating time depends on the fuse type, supply network impedance and the cross-sectional area, material and length of the supply cable. The fuses must be of the “non-time delay” type. Obey local regulations.

Drive type ACS880-07-	Input current A	Fuse (one fuse per phase)					
		A	V	Manufacturer	Type	Type with option +F289	UL class / Size
$U_N = 460\text{ V}$							
0096A-5	96	250	600	Bussmann	DFJ-250	170M3414	J/1
0124A-5	124	250	600	Bussmann	DFJ-250	170M3416	J/1
0156A-5	156	300	600	Bussmann	DFJ-300	170M3416	J/1
0180A-5	180	300	600	Bussmann	DFJ-300	170M4410	J/1
0240A-5	240	400	600	Bussmann	DFJ-400	170M5408	J/2
0260A-5	260	400	600	Bussmann	DFJ-400	170M5410	J/2
0302A-5	375	630	690	Bussmann	170M6410	170M6410	3
0361A-5	361	630	600	Bussmann	170M6410	170M6410	3
0414A-5	414	700	600	Bussmann	170M6411	170M6411	3
0460A-5	460	630	690	Bussmann	170M6410	170M6411	3
0503A-5	503	700	690	Bussmann	170M6411	170M6412	3
0583A-5	583	700	690	Bussmann	170M6411	170M6413	3
0635A-5	635	800	690	Bussmann	170M6412	170M6414	3
0715A-5	715	900	690	Bussmann	170M6413	170M6416	3
0820A-5	820	1000	690	Bussmann	170M6414	170M6416	3
0880A-5	880	1400	690	Bussmann	170M6417	170M6417	3

Drive type ACS880-07-	Input current A	Fuse (one fuse per phase)					
		A	V	Manufacture r	Type	Type with option +F289	UL class / Size
$U_N = 600 \text{ V}$							
0061A-7	61	250	600	Bussmann	DFJ-250	170M3412	J/1
0084A-7	84	250	600	Bussmann	DFJ-250	170M3414	J/1
0098A-7	98	250	600	Bussmann	DFJ-250	170M3414	J/1
0119A-7	119	250	600	Bussmann	DFJ-250	170M3416	J/1
0142A-7	142	250	600	Bussmann	DFJ-250	170M3416	J/1
0174A-7	174	300	600	Bussmann	DFJ-300	170M4410	J/1
0210A-7	210	315	690	Bussmann	170M4410	170M4410	1
0271A-7	271	500	690	Bussmann	170M5410	170M5410	2
0330A-7	330	630	690	Bussmann	170M6410	170M6410	3
0370A-7	370	630	690	Bussmann	170M6410	170M6410	3
0430A-7	430	700	690	Bussmann	170M6411	170M6411	3
0470A-7	470	800	690	Bussmann	170M6412	170M6412	3
0522A-7	522	800	690	Bussmann	170M6412	170M6412	3
0590A-7	590	900	690	Bussmann	170M6413	170M6413	3
0650A-7	650	1000	690	Bussmann	170M6414	170M6414	3
0721A-7	721	1250	690	Bussmann	170M6416	170M6416	3

Note 1: See also [Implementing thermal overload and short-circuit protection](#) on page 75.

Note 2: Fuses with higher current rating than the recommended ones must not be used. Fuses with lower current rating can be used.

Note 3: Fuses from other manufacturers can be used if they meet the ratings and the melting curve of the fuse does not exceed the melting curve of the fuse mentioned in the table.

Note 4: Circuit breakers must not be used without fuses.

Dimensions and weights

Frame size	Height ¹⁾				Width ²⁾		Depth ³⁾		Weight	
	IP22/42		IP54		mm	in.	mm	in.	kg	lb
	mm	in.	mm	in.						
R6	2145	84.45	2315	91.14	430	16.93	673	26.50	240	530
R7	2145	84.45	2315	91.14	430	16.93	673	26.50	250	560
R8	2145	84.45	2315	91.14	430	16.93	673	26.50	265	590
R9	2145	84.45	2315	91.14	830	32.68	698	27.48	375	830
R10	2145	84.45	2315	91.14	830	32.68	698	27.48	530	1170
R11	2145	84.45	2315	91.14	830	32.68	698	27.48	580	1280

1) For marine construction (option +C121) extra height is 10 mm (0.39 in.) due to the fastening bars at the bottom of the cabinet.

2) Extra width with brake resistors (option +D151): SAFURxxxFxxx 400 mm (15.75 in.), 2×SAFURxxxFxxx 800 mm (19.68 in.). Extra width for frames R6 to R8 with EMC filter (option +E202): 200 mm (7.87 in.). Total width of R6 to R9 frame sizes with molded case circuit breaker (option +F289) is 830 mm (32.68 in.)

3) For drives with marine fastening bars (option +C121): Depth is 757 mm.

■ Dimensions and weights of sine filter cabinet (option +E206)

Frame size	Height				Widt		Dept		Weight	
	IP22/42		IP54		mm	in.	mm	in.	kg	lb
	mm	in.	mm	in.						
R6	2130	83.86	2310	90.94	630	24.80	646	25.43	400	880
R7	2130	83.86	2310	90.94	630	24.80	646	25.43	400	880
R8	2130	83.86	2310	90.94	630	24.80	646	25.43	400	880
R9	2130	83.86	2310	90.94	630	24.80	646	25.43	400	880
R10	2130	83.86	2310	90.94	1030	24.80	646	25.43	300	660
R11	2130	83.86	2310	90.94	1030	24.80	646	25.43	700	1540

Free space requirements

Front		Side		Above*	
mm	in.	mm	in.	mm	in.
150	5.91	-	-	400	15.75

* measured from the base plate of the cabinet top. **Note:** 320 mm (12.28 in.) is required for fan replacement of IP54 cabinets.

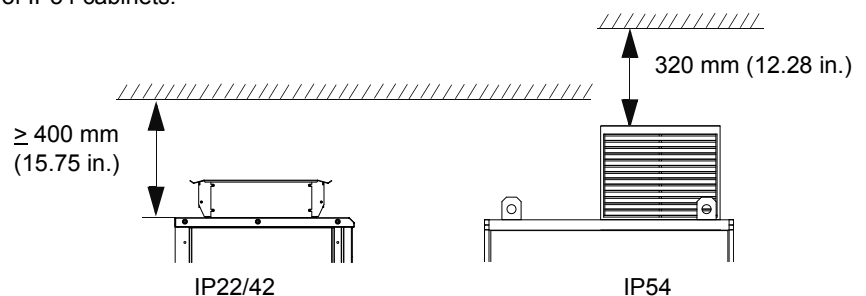

Door opening:

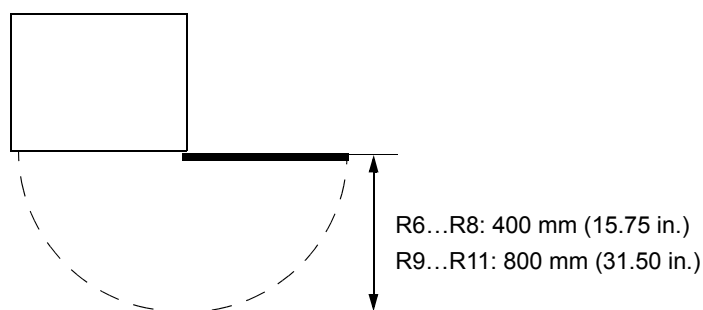

Losses, cooling data and noise

Drive type	Frame	Air flow		Heat dissipation	Noise	Noise with sine filter (option +E206)
		m ³ /h	ft ³ /min			
U_N = 400 V						
ACS880-07-0105A-3	R6	1750	1130	1795	67	80
ACS880-07-0145A-3	R6	1750	1130	1940	67	80
ACS880-07-0169A-3	R7	1750	1130	2440	67	80
ACS880-07-0206A-3	R7	1750	1130	2810	67	80
ACS880-07-0246A-3	R8	1750	1130	3800	65	80
ACS880-07-0293A-3	R8	1750	1130	4400	65	80
ACS880-07-0363A-3	R9	1150	677	5300	68	80
ACS880-07-0430A-3	R9	1150	677	6500	68	80
ACS880-07-0505A-3	R10	2950	1837	6102	72	80
ACS880-07-0585A-3	R10	2950	1837	6909	72	80
ACS880-07-0650A-3	R10	2950	1837	8622	72	80
ACS880-07-0725A-3	R11	2950	1837	9264	72	80
ACS880-07-0820A-3	R11	2950	1837	10362	72	80
ACS880-07-0880A-3	R11	3170	1978	11078	71	80
U_N = 500 V						
ACS880-07-0096A-5	R6	1750	1130	1795	67	80
ACS880-07-0124A-5	R6	1750	1130	1940	67	80
ACS880-07-0156A-5	R7	1750	1130	2440	67	80
ACS880-07-0180A-5	R7	1750	1130	2810	67	80
ACS880-07-0240A-5	R8	1750	1130	3800	65	80
ACS880-07-0260A-5	R8	1750	1130	4400	65	80
ACS880-07-0302A-5	R9	1150	677	4700	68	
ACS880-07-0361A-5	R9	1150	677	5300	68	80
ACS880-07-0414A-5	R9	1150	677	6500	68	80
ACS880-07-0460A-5	R10	2950	1837	4903	72	80
ACS880-07-0503A-5	R10	2950	1837	6102	72	80
ACS880-07-0583A-5	R10	2950	1837	6909	72	80
ACS880-07-0635A-5	R10	2950	1837	8622	72	80
ACS880-07-0715A-5	R11	2950	1837	9264	72	80
ACS880-07-0820A-5	R11	2950	1837	10362	71	80
ACS880-07-0880A-5	R11	2950	1837	11078	71	80
U_N = 690 V						
ACS880-07-0061A-7	R6	1750	1130	1795	67	78
ACS880-07-0084A-7	R6	1750	1130	1940	67	79
ACS880-07-0098A-7	R7	1750	1130	2440	67	79
ACS880-07-0119A-7	R7	1750	1130	2810	67	80
ACS880-07-0142A-7	R8	1750	1130	3800	65	80
ACS880-07-0174A-7	R8	1750	1130	4400	65	80
ACS880-07-0210A-7	R9	1150	677	4700	68	80

Drive type	Frame	Air flow		Heat dissipation W	Noise dB(A)	Noise with sine filter (option +E206)
		m ³ /h	ft ³ /min			
ACS880-07-0271A-7	R9	1150	677	5300	68	80
ACS880-07-0330A-7	R10	2950	1837	4903	72	80
ACS880-07-0370A-7	R10	2950	1837	6102	72	80
ACS880-07-0430A-7	R10	2950	1837	6909	72	80
ACS880-07-0470A-7	R11	2950	1837	8622	72	80
ACS880-07-0522A-7	R11	2950	1837	9264	72	80
ACS880-07-0590A-7	R11	2950	1837	10362	71	80
ACS880-07-0650A-7	R11	3170	1978	11078	71	80
ACS880-07-0721A-7	R11	3170	1978	11078	71	80

Cooling data and noise for drives with sine filter (option +E206)

Drive type ACS880-07-xxxxx- x+E206	Frame	Heat dis-sipation *	Air flow		
			Drive	Filter	Total
		kW	m ³ /h	m ³ /h	m ³ /h
$U_N = 400\text{ V}$					
ACS880-07-0105A-3	R6	0.6	1750	*	1750
ACS880-07-0145A-3	R6	0.55	1750	*	1750
ACS880-07-0169A-3	R7	0.55	1750	*	1750
ACS880-07-0206A-3	R7	0.9	1750	*	1750
ACS880-07-0246A-3	R8	0.9	1750	*	1750
ACS880-07-0293A-3	R8	1.6	1750	*	1750
ACS880-07-0363A-3	R9	1.6	1150	*	1150
ACS880-07-0430A-3	R9	1.6	1150	*	1150
ACS880-07-0505A-3	R10	3.0	2950	2000	4950
ACS880-07-0585A-3	R10	3.4	2950	2000	4950
ACS880-07-0650A-3	R10	3.8	2950	2000	4950
ACS880-07-0725A-3	R11	4.1	2950	2000	4950
ACS880-07-0820A-3	R11	4.7	2950	2000	4950
ACS880-07-0880A-3	R11	5.0	3170	2000	5170
$U_N = 500\text{ V}$					
ACS880-07-0096A-5	R6	0.63	1750	*	1750
ACS880-07-0124A-5	R6	0.63	1750	*	1750
ACS880-07-0156A-5	R7	0.55	1750	*	1750
ACS880-07-0180A-5	R7	0.55	1750	*	1750
ACS880-07-0240A-5	R8	0.9	1750	*	1750
ACS880-07-0260A-5	R8	0.9	1750	*	1750
ACS880-07-0361A-5	R9	1.6	1150	*	1150
ACS880-07-0414A-5	R9	1.6	1150	*	1150
ACS880-07-0460A-5	R10	3.3	2950	2000	4950
ACS880-07-0503A-5	R10	3.6	2950	2000	4950

Drive type ACS880-07-xxxxx- x+E206	Frame	Heat dis-sipation *	Air flow		
			Drive	Filter	Total
		kW	m ³ /h	m ³ /h	m ³ /h
ACS880-07-0583A-5	R10	3.9	2950	2000	4950
ACS880-07-0635A-5	R10	4.3	2950	2000	4950
ACS880-07-0715A-5	R11	4.9	2950	2000	4950
ACS880-07-0820A-5	R11	5.6	2950	2000	4950
ACS880-07-0880A-5	R11	5.6	2950	2000	4950
$U_N = 690$ V					
ACS880-07-0061A-7	R6	0.3	1750	*	1750
ACS880-07-0084A-7	R6	0.6	1750	*	1750
ACS880-07-0098A-7	R7	0.6	1750	*	1750
ACS880-07-0119A-7	R7	0.63	1750	*	1750
ACS880-07-0142A-7	R8	0.63	1750	*	1750
ACS880-07-0174A-7	R8	0.9	1750	*	1750
ACS880-07-0210A-7	R9	0.9	1150	*	1150
ACS880-07-0271A-7	R9	0.9	1150	*	1150
ACS880-07-0330A-7	R10	2.2	2950	700	2950
ACS880-07-0370A-7	R10	2.3	2950	700	3650
ACS880-07-0430A-7	R10	2.4	2950	700	3650
ACS880-07-0470A-7	R11	3.2	2950	2000	4950
ACS880-07-0522A-7	R11	3.6	2950	2000	4950
ACS880-07-0590A-7	R11	4.0	2950	2000	4950
ACS880-07-0650A-7	R11	4.9	3170	2000	5170
ACS880-07-0721A-7	R11	4.9	3170	2000	5170

* Natural convection

Sine filter is not available for ACS880-07-0302A-5.

Terminal and lead-through data for the power cables

■ IEC

Frame size	Number of holes in the lead-through plate for the power cables. Hole diameter 60 mm.	Terminals L1, L2, L3, U2, V2, W2, UDC+/R+, UDC- and R-			Grounding terminals	
		Max. phase conductor size mm ²	Bolt size	Tightening torque	Bolt size	Tightening torque N·m
R6	6	185	M10	20...40 N·m	M10	30...44 N·m
R7	6	185				
R8	6	1×240 or 2×185	M12	50...75 N·m		
R9	9	3×240				
R10	12	3×240 or 4×185				
R11	12	3×240 or 4×185				

■ US

Frame size	Terminals L1, L2, L3, U2, V2, W2, UDC+/R+, UDC- and R-			Grounding terminals	
	Max. phase conductor size AWG/kcmil	Busbar bolt size – Hole spacing	Tightening torque bf·ft	Bolt size	Tightening torque bf·ft
R6	350 MCM	M10 (3/8") × 2 – 1.75"	15...30	M10 (3/8")	22...32
R7					
R8	1×500 MCM or 2×350 MCM	M12 (7/16") × 2 – 1.75"	37...55		
R9	2×500 MCM				
R10	1×500 MCM or 4×350 MCM				
R11	1×500 MCM or 4×350 MCM	M12 (7/16") × 4 – 1.75"			

Input and motor cable terminal dimensions of frames R6 to R7

Bottom entry and exit:

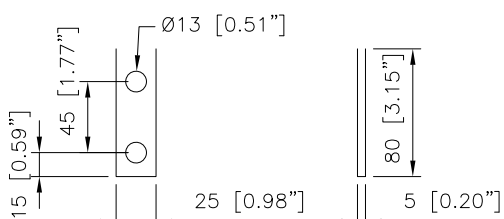

Top entry and exit:

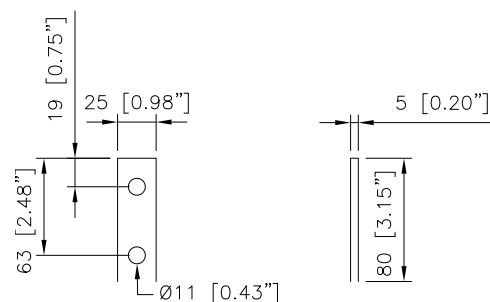

Input and motor cable terminal dimensions of frame R8

Bottom entry and exit:

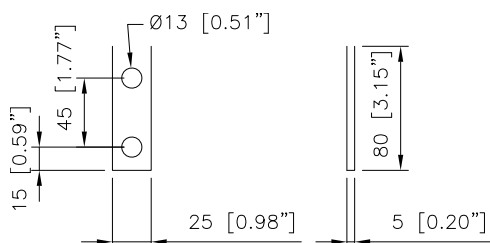

Top entry and exit:

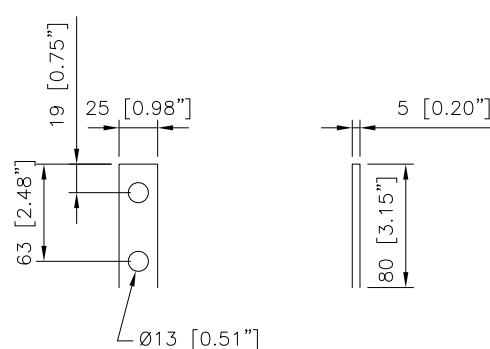

Resistor and DC cable terminal dimensions of frames R6 to R8

Bottom entry and exit:

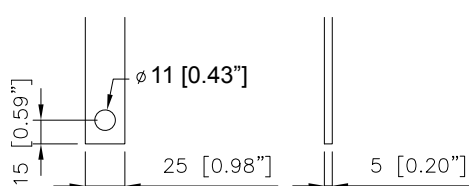

Power cable terminal dimensions of frame R8

Top entry and exit:

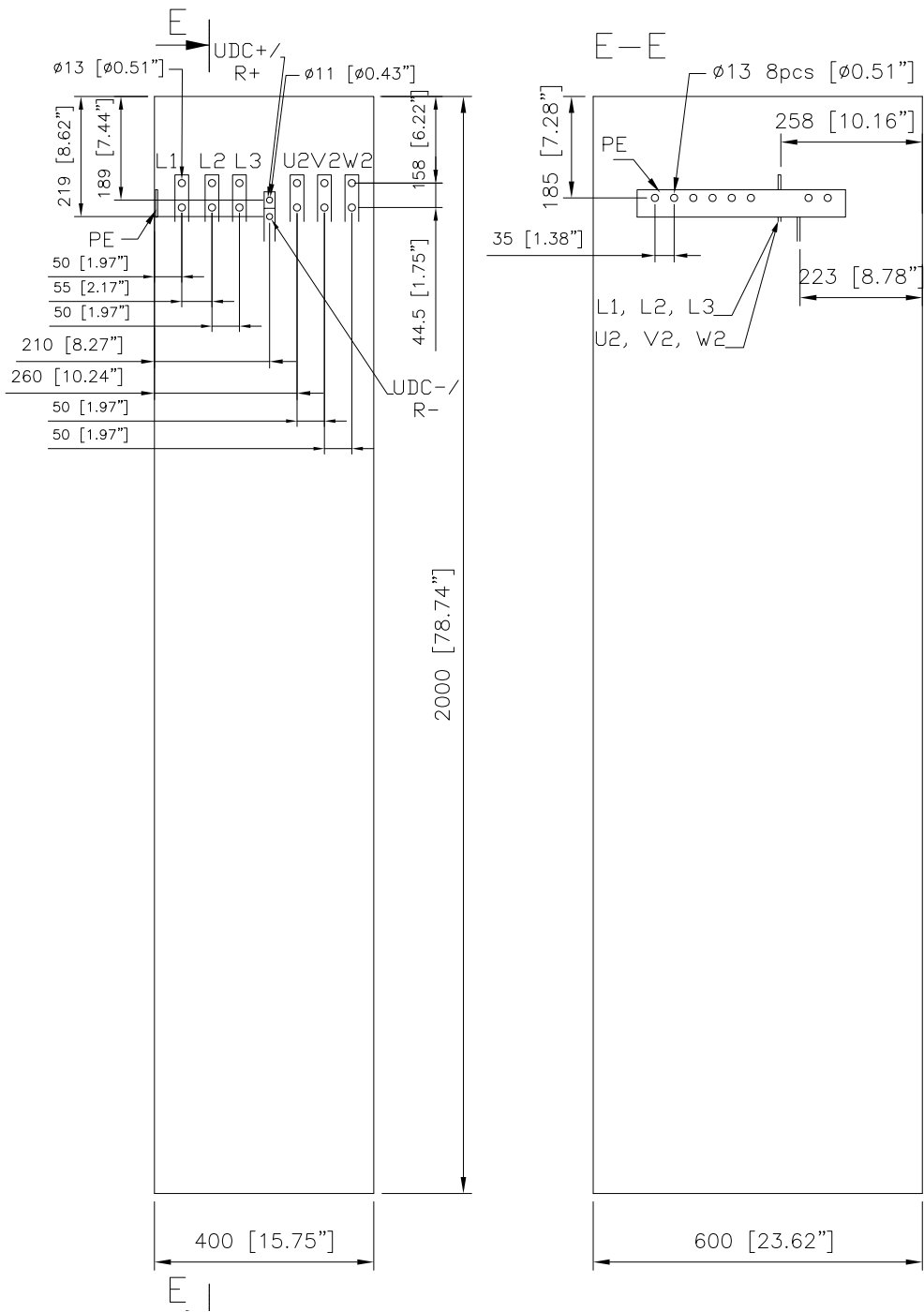

Motor cable terminal dimensions of frame R9 – Units with optional du/dt filter (+E205):

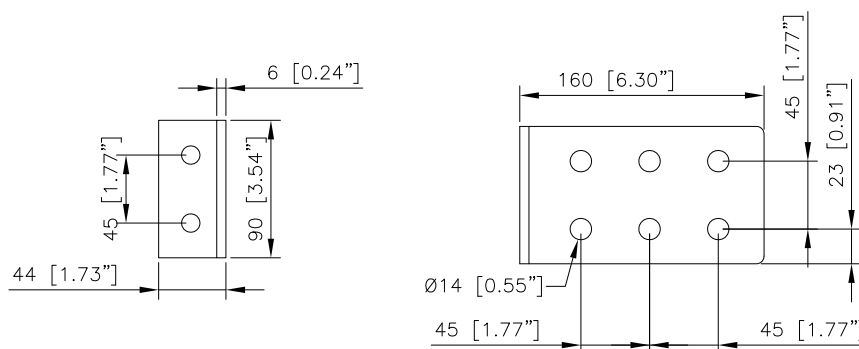

Motor cable terminal dimensions of frame R9 – Units without optional du/dt filter (+E205):

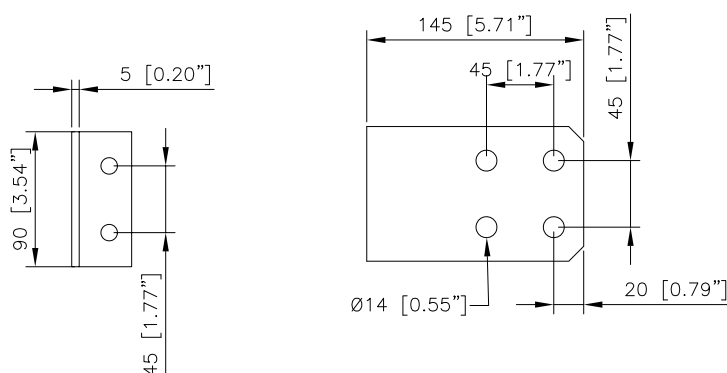

Input cable terminal dimensions of frame R9:

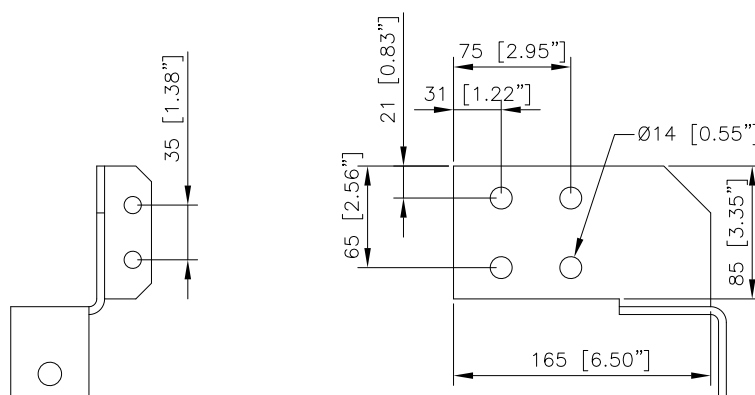

Resistor and DC cable terminal dimensions of frames R9

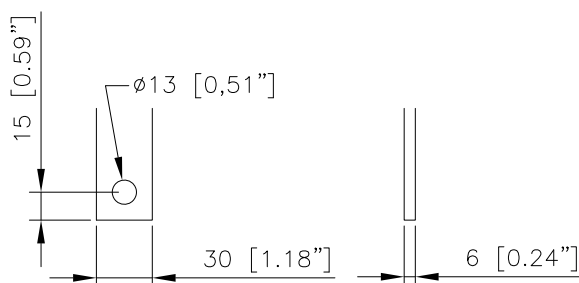

Input and motor cable terminal dimensions of frame R10

Bottom entry and exit:

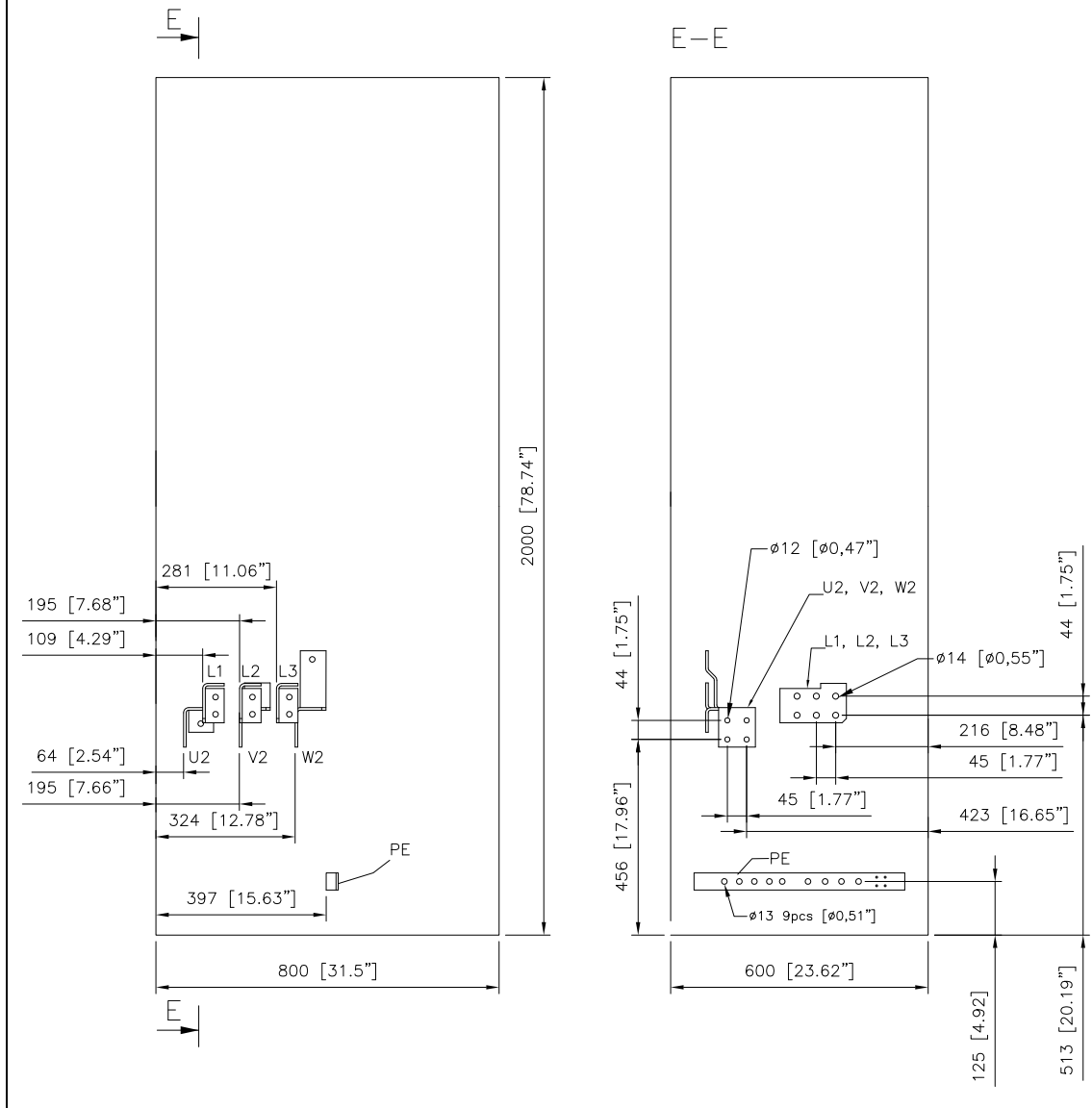

Input and motor cable terminal dimensions of frame R11

Bottom entry and exit:

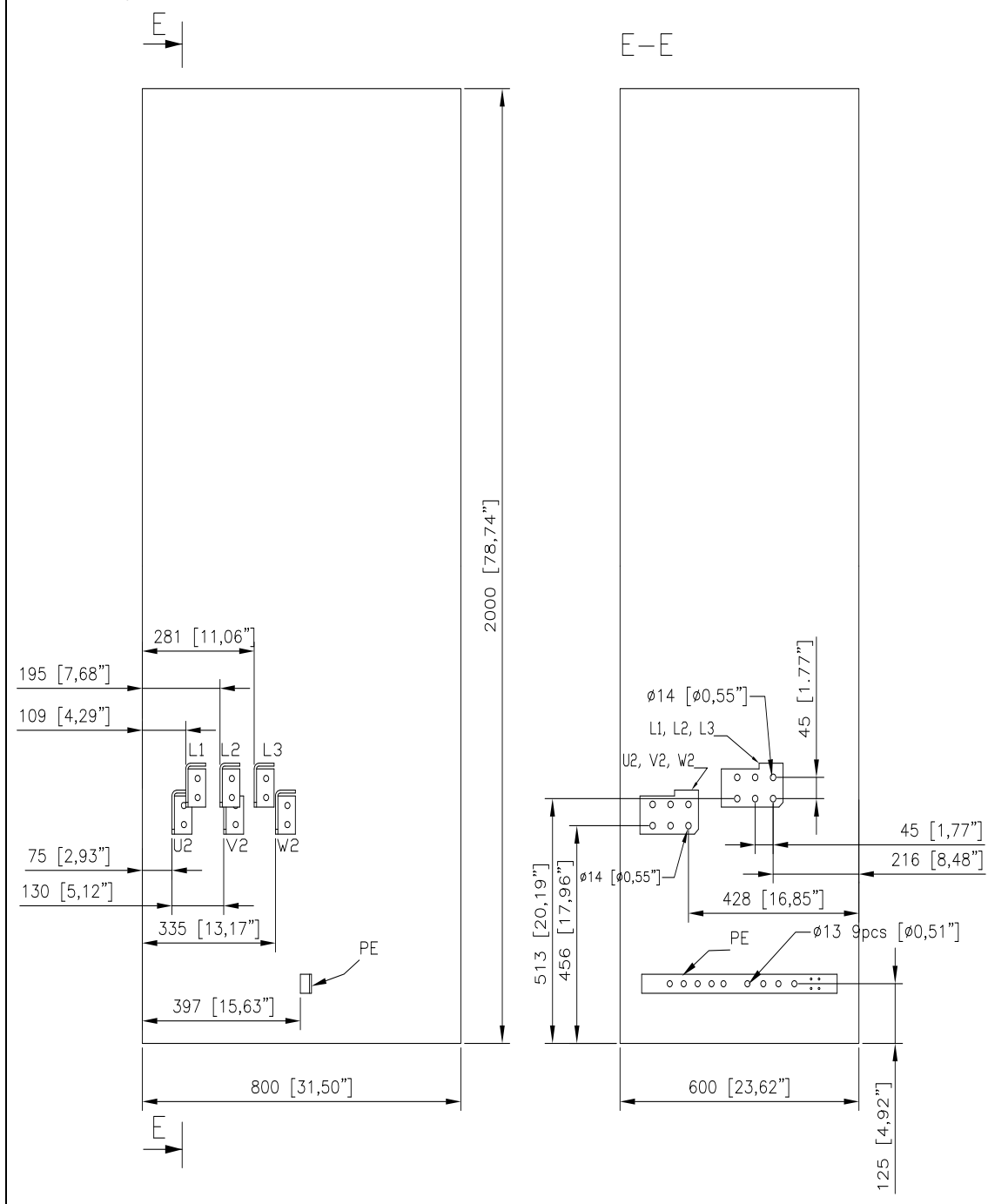

Input and motor cable terminal dimensions of frames R10 and R11

Top entry and exit (option +H351+H353):

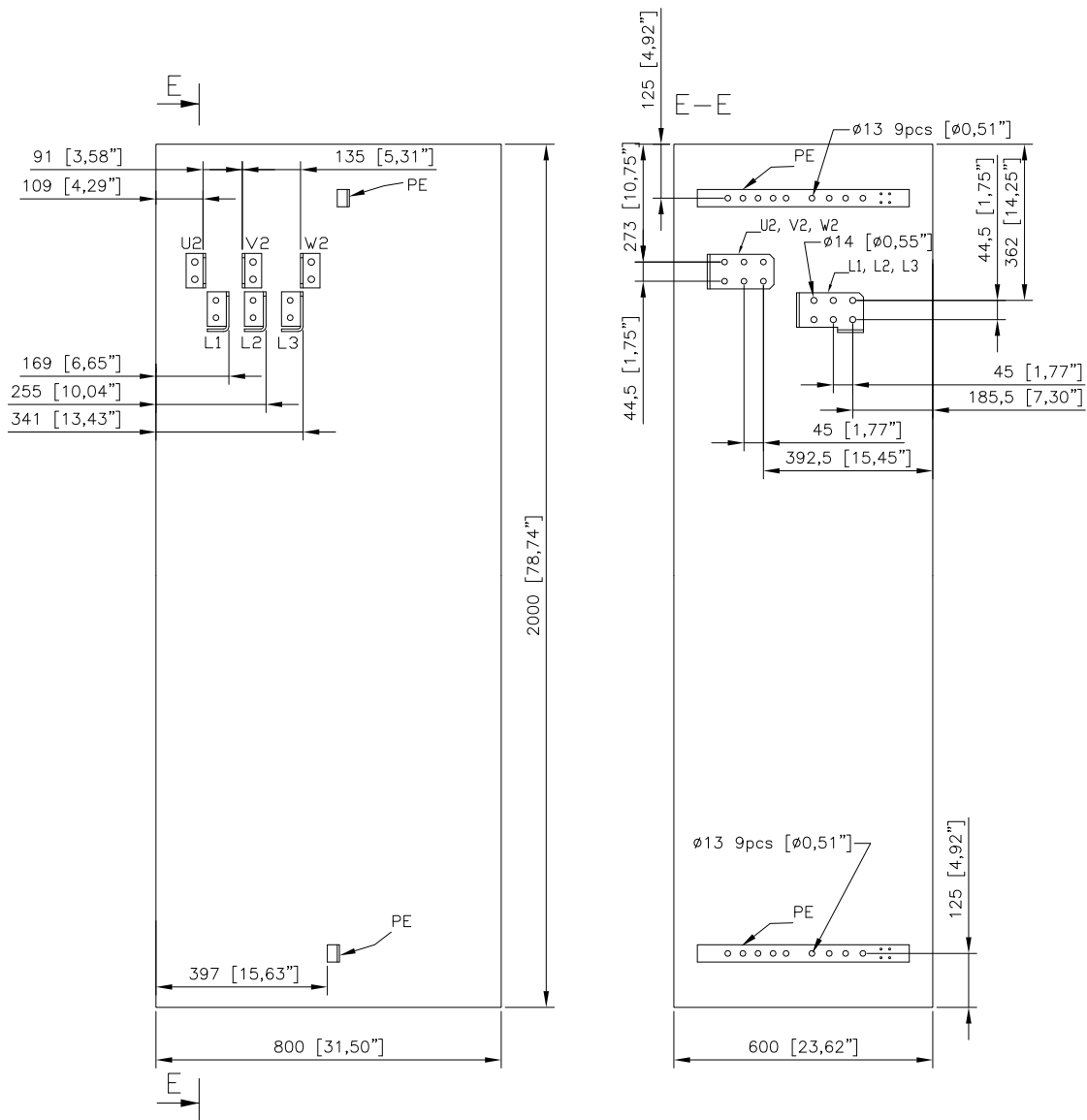

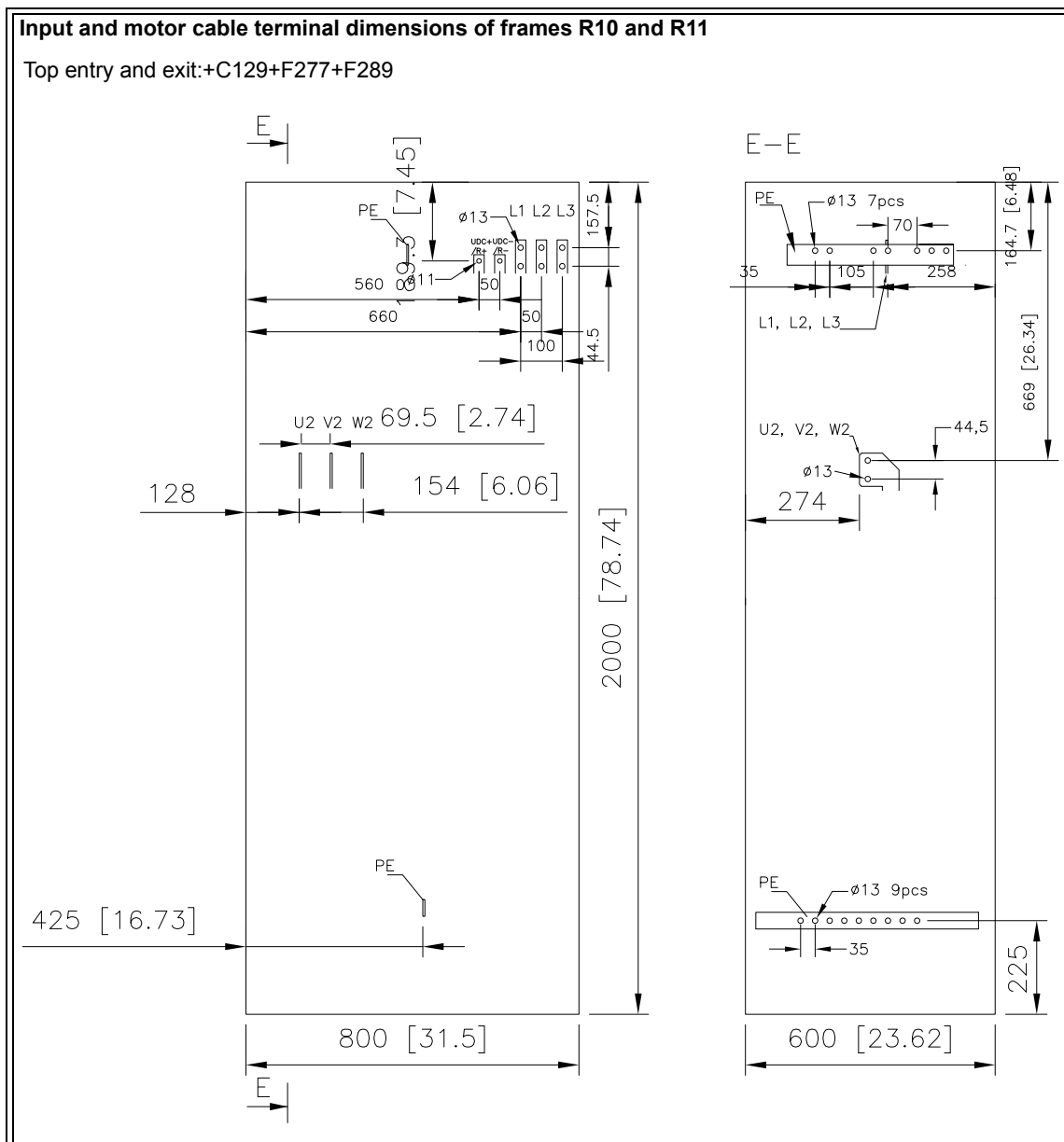

Terminal data for the control cables

See chapter [Control unit of frames R6 to R9](#) on page 125 or [Control unit of frames R10 and R11](#) on page 135.

Electrical power network specification

Voltage (U_1)	<p><u>ACS880-07-xxxx-3 drives:</u> 380...415 VAC 3-phase +10%...-15%. This is indicated in the type designation label as typical input voltage level 3 ~ 400 V AC.</p> <p><u>ACS880-07-xxxx-5 drives:</u> 380...500 VAC 3-phase +10%...-15%. This is indicated in the type designation label as typical input voltage levels 3 ~ 400/480/500 V AC.</p> <p><u>ACS880-07-xxxx-7 drives:</u> 525...690 VAC 3-phase +10%...-15%. This is indicated in the type designation label as typical input voltage levels 3 ~ 525/600/690 V AC.</p>
Network type	TN (grounded) and IT (ungrounded) systems
Short-circuit withstand strength (IEC 61439-1)	<p>Maximum allowable prospective short-circuit current is 65 kA when the input cable is protected with gG type fuses (IEC 60269) having maximum operating time of 0.1 seconds and maximum current rating as follows:</p> <ul style="list-style-type: none"> • 400 A for frames R6 to R8 • 630 A for frame R9 • 1250 A for frames R10 and R11.
Short-circuit current protection (UL 508A)	The drive is suitable for use on a circuit capable of delivering not more than 100,000 rms symmetrical amperes at 600 V maximum when the input cable is protected with T class fuses.
Short-circuit current protection (CSA C22.2 No. 14-05)	The drive is suitable for use on a circuit capable of delivering not more than 100 kA rms symmetrical amperes at 600 V maximum when the input cable is protected with T class fuses.
Frequency	47 to 63 Hz, maximum rate of change 17%/s
Imbalance	Max. \pm 3% of nominal phase to phase input voltage
Fundamental power factor ($\cos \phi_1$)	0.98 (at nominal load)

Motor connection data

Motor types	Asynchronous AC induction motors, permanent magnet synchronous motors, AC induction servomotors and ABB synchronous reluctance motors (SynRM motors) with option +N7502
Voltage (U_2)	0 to U_1 , 3-phase symmetrical, U_{\max} at the field weakening point
Frequency	<p>0...500 Hz</p> <p><u>For drives with du/dt filter:</u> 120 Hz (frames R6 to R9), 200 Hz (frames (R10 and R11))</p> <p><u>For drives with sine filter:</u> 120 Hz</p>
Current	See section Ratings .
Switching frequency	<p><u>For frames R6 to R9:</u> 2.7 kHz (typically)</p> <p><u>For frames R10 and R11:</u> 3 kHz (typically)</p>
Maximum recommended motor cable length	<p>300 m (984 ft).</p> <p>Note: For frames R6 to R9 with motor cables longer than 150 m (492 ft) for frames R10 and R11 with motor cables longer than 100 m (328 ft), the EMC Directive requirements may not be fulfilled.</p>

Control unit connection data

See chapter [Control unit of frames R6 to R9](#) on page 125 or chapter [Control unit of frames R10 and R11](#) on page 135.

Efficiency

Approximately 98% at nominal power level

Protection classes

Degrees of protection (IEC/EN 60529)	IP22, IP42, IP54
Enclosure types (UL50)	UL Type 1, UL Type 1 Filtered, UL Type 12. For indoor use only.
Overvoltage category (IEC 60664-1)	III
Protective class (IEC/EN 61800-5-1)	I

Ambient conditions

Environmental limits for the drive are given below. The drive is to be used in a heated, indoor, controlled environment.

	Operation installed for stationary use	Storage in the protective package	Transportation in the protective package
Installation site altitude	0 to 4000 m (13123 ft) above sea level [above 1000 m (3281 ft), see section Derating]	-	-
Air temperature	-0 to +50 °C (32 to 122 °F). No frost allowed. See section Derating .	-40 to +70 °C (-40 to +158 °F)	-40 to +70 °C (-40 to +158 °F)
Relative humidity	5 to 95%	Max. 95%	Max. 95%
	No condensation allowed. Maximum allowed relative humidity is 60% in the presence of corrosive gases.		
Contamination levels (IEC 60721-3-3, IEC 60721-3-2, IEC 60721-3-1)	No conductive dust allowed.		
	Chemical gases: Class 3C2 Solid particles: Class 3S2	Chemical gases: Class 1C2 Solid particles: Class 1S3	Chemical gases: Class 2C2 Solid particles: Class 2S2
Atmospheric pressure	70 to 106 kPa 0.7 to 1.05 atmospheres	70 to 106 kPa 0.7 to 1.05 atmospheres	60 to 106 kPa 0.6 to 1.05 atmospheres
Vibration (IEC 60068-2)	Max. 1 mm (0.04 in.) (5 to 13.2 Hz), max. 7 m/s ² (23 ft/s ²) (13.2 to 100 Hz) sinusoidal	Max. 1 mm (0.04 in.) (5 to 13.2 Hz), max. 7 m/s ² (23 ft/s ²) (13.2 to 100 Hz) sinusoidal	Max. 3.5 mm (0.14 in.) (2 to 9 Hz), max. 15 m/s ² (49 ft/s ²) (9 to 200 Hz) sinusoidal
Shock (IEC 60068-2-29)	Not allowed	Max. 100 m/s ² (330 ft./s ²), 11 ms	Max. 100 m/s ² (330 ft./s ²), 11 ms
Free fall	Not allowed	100 mm (4 in.) for weight over 100 kg (220 lb)	100 mm (4 in.) for weight over 100 kg (220 lb)

Auxiliary circuit power consumption

Cabinet heater and cabinet lighting (options +G300 and +G301)	100 W
External uninterruptible power supply (option +G307)	150 W

Motor heater (option +G313) According to the heater type

Materials

Cabinet	Hot-dip zinc coated 1.5 mm thick steel sheet (thickness of coating approximately 20 micrometers). Polyester thermosetting powder coating (thickness approximately 80 micrometers) on visible surfaces, color RAL 7035 and RAL 9017. PC/ABS 3 mm, color NCS 1502-Y (RAL 9002 / PMS 1C Cool Grey).
Busbars	Tin-plated copper
Air filters of IP54 drives	Inlet (door): airComp 300-50 288 mm x 521 mm (ABB code: 64640194) 688 mm x 521 mm (ABB code 64748017) Outlet (roof): airTex G150 2 pcs: 398 mm x 312 mm (ABB code: 64722166)
Fire safety of materials (IEC 60332-1)	Insulating materials and non-metallic items mostly self-extinctive
Package	<p>Standard package:</p> <ul style="list-style-type: none"> timber, polyethylene sheet (thickness 0.2 mm), stretch film (thickness 0.023 mm), PP tape, PET strap, sheet metal (steel) for land and air transport when planned storage time is less than 2 months or when storage can be arranged in clean and dry conditions less than 6 months can be used when products will not be exposed to corrosive atmosphere during transport or storage <p>Container package:</p> <ul style="list-style-type: none"> timber, VCI sheet film (PE, thickness 0.15 mm), VCI stretch film (PE, thickness 0.04 mm), VCI emitter bags, PP tape, PET strap, sheet metal (steel) for sea transport in containers recommended for land and air transport when storage time prior to installation exceeds 6 months or storage is arranged in partially weather-protected conditions <p>Seaworthy package:</p> <ul style="list-style-type: none"> timber, plywood, VCI sheet film (PE, thickness 0.15 mm), VCI stretch film (PE, thickness 0.04 mm), VCI emitter bags, PP tape, PET strap, sheet metal (steel) for sea transport with or without containerization for long storage periods in environments where roofed and humidity-controlled storage cannot be arranged <p>Cabinets are fastened to the pallet with screws and braced from the top end to the package walls to prevent swaying inside the package. Package elements are attached together with screws. For handling the packages, see section Moving and unpacking the drive on page 57.</p>
Disposal	<p>The main parts of the drive can be recycled to preserve natural resources and energy. Product parts and materials should be dismantled and separated.</p> <p>Generally all metals, such as steel, aluminum, copper and its alloys, and precious metals can be recycled as material. Plastics, rubber, cardboard and other packaging material can be used in energy recovery. Printed circuit boards and DC capacitors (C1-1 to C1-x) need selective treatment according to IEC 62635 guidelines. To aid recycling, plastic parts are marked with an appropriate identification code.</p> <p>Contact your local ABB distributor for further information on environmental aspects and recycling instructions for professional recyclers. End of life treatment must follow international and local regulations.</p>

Applicable standards

	The drive complies with the standards below. The compliance with the European Low Voltage Directive is verified according to standard EN 61800-5-1.
EN 61800-5-1:2007	<i>Adjustable speed electrical power drive systems. Part 5-1: Safety requirements – electrical, thermal and energy</i>
EN 60204-1:2006 +A1 2009	<i>Safety of machinery. Electrical equipment of machines. Part 1: General requirements. Provisions for compliance: The final assembler of the machine is responsible for installing emergency-stop device.</i>
IEC/EN 60529:1991 + A1 2000	<i>Degrees of protection provided by enclosures (IP code)</i>
EN 61800-3:2004	<i>Adjustable speed electrical power drive systems. Part 3: EMC requirements and specific test methods</i>
UL 501:2007	<i>Enclosures for Electrical Equipment, Non-Environmental Considerations</i>
UL 508C:2002	<i>UL Standard for Safety, Power Conversion Equipment, third edition</i>
UL 508A: 2001	<i>UL Standard for Industrial Control Panels, first edition</i>
CSA C22.2 No. 14-10	<i>Industrial control equipment</i>
GOST R 51321-1:2007	<i>Low-voltage Switchgear And Control Gear Assemblies. Part 1 - Requirements For Type-tested And Partially Type-tested Assemblies - General Technical Requirements And Methods Of Tests</i>

CE marking

A CE mark is attached to the drive to verify that the drive complies with the provisions of the European Low Voltage and EMC Directives. The CE marking also verifies that the drive, in regard to its safety functions (such as Safe torque off), conforms with the Machinery Directive as a safety component.

■ Compliance with the European Low Voltage Directive

The compliance with the European Low Voltage Directive has been verified according to standard EN 61800-5-1.

■ Compliance with the European EMC Directive

The EMC Directive defines the requirements for immunity and emissions of electrical equipment used within the European Union. The EMC product standard (EN 61800-3:2004) covers requirements stated for drives. See section [Compliance with the EN 61800-3:2004](#) below.

■ Compliance with the European Machinery Directive

The drive is an electronic product which is covered by the European Low Voltage Directive. However, the drive includes the Safe torque off function and can be equipped with other safety functions for machinery which, as safety components, are in the scope of the Machinery Directive. These functions of the drive comply with European harmonized standards such as EN 61800-5-2. The declaration of conformity is shown below.

Declaration of Conformity (Safe torque off)

See also chapter [Safe torque off function](#) on page 229 and section [Implementing the functions provided by the FSO-xx safety functions module \(option +Q972 or +Q973\)](#) on page 86.



Declaration of Conformity

(According to Machinery Directive 2006/42/EC)

Manufacturer: ABB Oy, Drives
Address: Hiomotie 13, P.O. Box 184, 00381 Helsinki, Finland.

hereby declares that products

ACS880-04, -14, -34	380V – 690V (frames nxR8i)
ACS880-04XT	380V – 690V (frames 2xR10 and 2xR11)
ACS880-07	380V – 690V (frames R6 – R11 and nxR8i)
ACS880-17, -37	380V – 690V (frames nxR8i)
ACS880-104	380V – 690V (frames R1i – nxR8i)
ACS880 multidrives	380V – 690V (inverter frames R1i – nxR8i)

with regard to the safety functions

Safe torque off

Safe stop 1, Safe stop emergency, Safely-limited speed, Safe maximum speed, Safe brake control, Prevention of unexpected start-up, with FSO-12 module (option code +Q973)

ACS880-07, -17, -37 and ACS880 multidrives: Prevention of unexpected start-up (option codes +Q950; +Q957), **Emergency stop** (option codes +Q951; +Q952; +Q963; +Q964; +Q978; +Q979), **Safely-limited speed** (option code +Q966)

fulfil all the relevant safety component requirements of EC Machinery Directive 2006/42/EC, when the listed safety functions are used for safety component functionality.

The following harmonized standards below were used:

EN 61800-5-2: 2007	<i>Adjustable speed electrical power drive systems – Part 5-2: Safety requirements - Functional</i>
EN 62061: 2005 + A1: 2013	<i>Safety of machinery – Functional safety of safety-related electrical, electronic and programmable electronic control systems</i>
EN ISO 13849-1: 2008 + AC: 2009	<i>Safety of machinery – Safety-related parts of control systems. Part 1: General requirements</i>
EN ISO 13849-2: 2012	<i>Safety of machinery – Safety-related parts of the control systems. Part 2: Validation</i>
EN 60204-1: 2006 + AC: 2010	<i>Safety of machinery – Electrical equipment of machines – Part 1: General requirements</i>

Other used standards:

IEC 61508 ed. 2: 2010	Functional safety of electrical / electronic / programmable electronic safety-related systems
-----------------------	---



Declaration of Conformity

(According to Machinery Directive 2006/42/EC)

The products referred in this Declaration of Conformity fulfil the relevant provisions of the Low Voltage Directive 2006/95/EC and EMC Directive 2004/108/EC. Declaration of conformity according to these directives is available from the manufacturer.

Person authorized to compile the technical file:

Name: Vesa Tiihonen
Address: P.O. Box 184, 00381 Helsinki, Finland

Helsinki, 1 Jul 2015

A handwritten signature in blue ink, appearing to read 'Peter Lindgren', is written over a horizontal line.

Peter Lindgren
Vice President
ABB Oy

Compliance with the EN 61800-3:2004

■ Definitions

EMC stands for **E**lectromagnetic **C**ompatibility. It is the ability of electrical/electronic equipment to operate without problems within an electromagnetic environment. Likewise, the equipment must not disturb or interfere with any other product or system within its locality.

First environment includes establishments connected to a low-voltage network which supplies buildings used for domestic purposes.

Second environment includes establishments connected to a network not supplying domestic premises.

Drive of category C2: drive of rated voltage less than 1000 V and intended to be installed and started up only by a professional when used in the first environment. **Note:** A professional is a person or organization having necessary skills in installing and/or starting up power drive systems, including their EMC aspects.

Drive of category C3: drive of rated voltage less than 1000 V and intended for use in the second environment and not intended for use in the first environment.

Drive of category C4: drive of rated voltage equal to or above 1000 V, or rated current equal to or above 400 A, or intended for use in complex systems in the second environment.

■ Category C2

The drive complies with the standard with the following provisions:

1. The drive is equipped with EMC filter E202.
2. The motor and control cables are selected as specified in the hardware manual.
3. The drive is installed according to the instructions given in the hardware manual.
4. Maximum motor cable length is 150 meters for frames R6 to R9 and 100 meters for frames R10 and R11.

WARNING! The drive may cause radio interference if used in a residential or domestic environment. The user is required to take measures to prevent interference, in addition to the requirements for CE compliance listed above, if necessary.

Note: Do not install a drive equipped with EMC filter E202 on IT (ungrounded) systems. The supply network becomes connected to ground potential through the EMC filter capacitors which may cause danger or damage the unit.

■ Category C3

The drive complies with the standard with the following provisions:

1. The drive is equipped with EMC filter E200, E201 or E210.
2. The motor and control cables are selected as specified in the hardware manual.
3. The drive is installed according to the instructions given in the hardware manual.
4. Maximum motor cable length is 150 meters for frames R6 to R9 and 100 meters for frames R10 and R11.

WARNING! A drive of category C3 is not intended to be used on a low-voltage public network which supplies domestic premises. Radio frequency interference is expected if the drive is used on such a network.

■ Category C4

If the provisions under [Category C3](#) cannot be met, the requirements of the standard can be met as follows:

1. It is ensured that no excessive emission is propagated to neighbouring low-voltage networks. In some cases, the natural suppression in transformers and cables is sufficient. If in doubt, the supply transformer with static screening between the primary and secondary windings can be used.

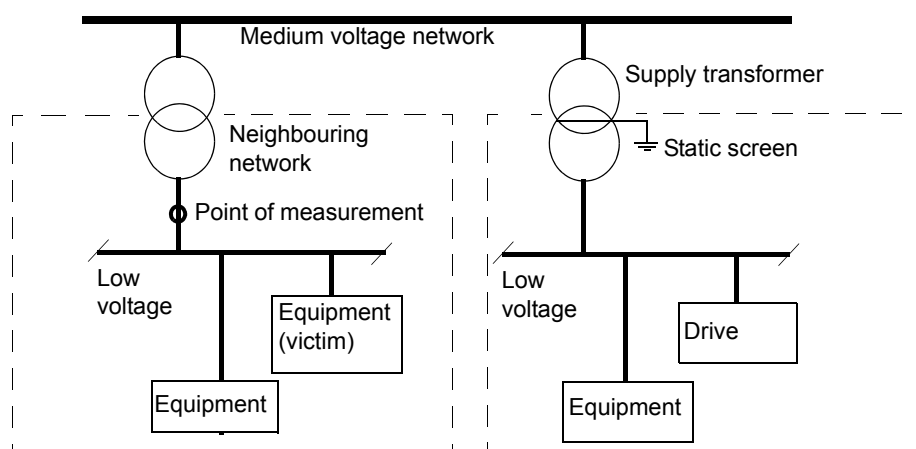

2. An EMC plan for preventing disturbances is drawn up for the installation. A template is available from the local ABB representative.
3. The motor and control cables are selected as specified in the hardware manual.
4. The drive is installed according to the instructions given in the hardware manual.

WARNING! A drive of category C4 is not intended to be used on a low-voltage public network which supplies domestic premises. Radio frequency interference is expected if the drive is used on such a network.

UL marking

The drive is cULus Listed.

■ UL checklist

- The drive is to be used in a heated, indoor controlled environment. The drive must be installed in clean air according to enclosure classification. Cooling air must be clean, free from corrosive materials and electrically conductive dust. See page [207](#).
- The maximum ambient air temperature is 40 °C (104 °F) at rated current. The current is derated for 40 to 50 °C (104 to 122 °F).
- The drive is suitable for use in a circuit capable of delivering not more than 100,000 rms symmetrical amperes, 600 V maximum when the input cable is protected with class T fuses. The ampere rating is based on tests done according to UL 508A.
- The cables located within the motor circuit must be rated for at least 75 °C (167 °F) in UL-compliant installations.
- The input cable must be protected with fuses. Circuit breakers must not be used without fuses in the USA. For suitable circuit breakers, contact your local ABB representative. Suitable IEC (class aR) fuses for drive protection are listed on page [192](#) and UL fuses on page [193](#).
- For installation in the United States, branch circuit protection must be provided in accordance with the National Electrical Code (NEC) and any applicable local codes. To fulfill this requirement, use the UL classified fuses.
- For installation in Canada, branch circuit protection must be provided in accordance with the Canadian Electrical Code and any applicable provincial codes. To fulfill this requirement, use the UL classified fuses.
- The drive provides overload protection in accordance with the National Electrical Code (NEC).

CSA marking

The drive is CSA marked.

“C-tick” marking

The drive is “C-tick” marked.

“C-tick” marking is required in Australia and New Zealand. A “C-tick” mark is attached to each drive in order to verify compliance with the relevant standard (IEC 61800-3:2004, *Adjustable speed electrical power drive systems – Part 3: EMC product standard including specific test methods*), mandated by the Trans-Tasman Electromagnetic Compatibility Scheme.

For fulfilling the requirements of the standard, see section [Compliance with the EN 61800-3:2004](#).

EAC marking

The drive has EAC certification. EAC marking is required in Russia, Belarus and Kazakhstan.

Cyber security disclaimer

This product is designed to be connected to and to communicate information and data via a network interface. It is Customer's sole responsibility to provide and continuously ensure a secure connection between the product and Customer network or any other network (as the case may be). Customer shall establish and maintain any appropriate measures (such as but not limited to the installation of firewalls, application of authentication measures, encryption of data, installation of anti-virus programs, etc) to protect the product, the network, its system and the interface against any kind of security breaches, unauthorized access, interference, intrusion, leakage and/or theft of data or information. ABB and its affiliates are not liable for damages and/or losses related to such security breaches, any unauthorized access, interference, intrusion, leakage and/or theft of data or information.

Disclaimer

The manufacturer shall have no obligation hereunder with respect to any product which (i) has been improperly repaired or altered; (ii) has been subjected to misuse, negligence or accident; (iii) has been used in a manner contrary to the Manufacturer's instructions; or (iv) has failed as a result of ordinary wear and tear..





14

Dimension drawings

Example dimension drawings with dimensions in millimeters and [inches] are shown below.

Frames R6 to R8 (IP22, IP42 [+B054], UL Type 1) – standard and options +C129, +H350, +H352

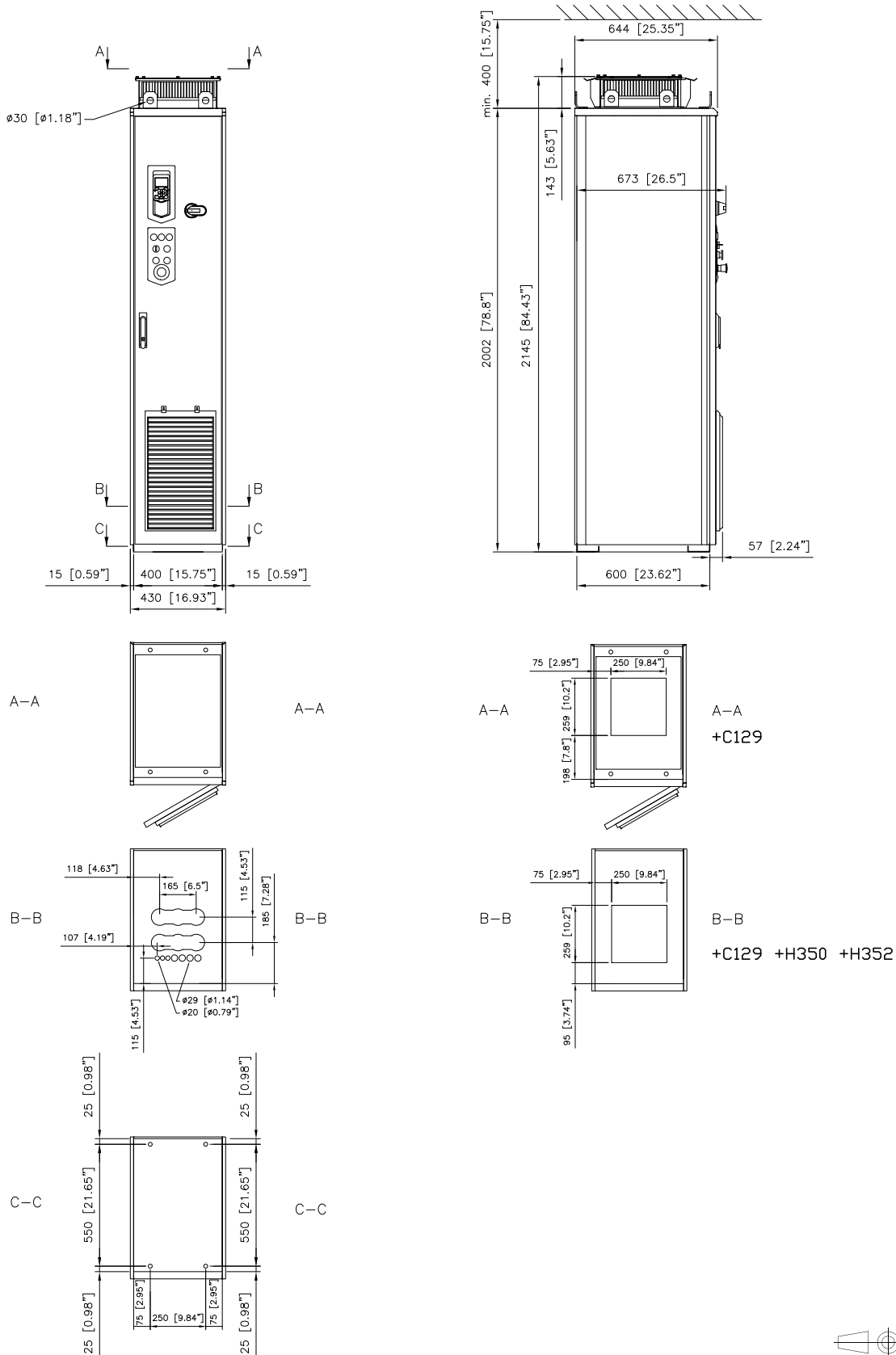

Frames R6 to R8 (IP54 / UL Type 12 [+B055]) – standard and options +C129, +H350, +H352

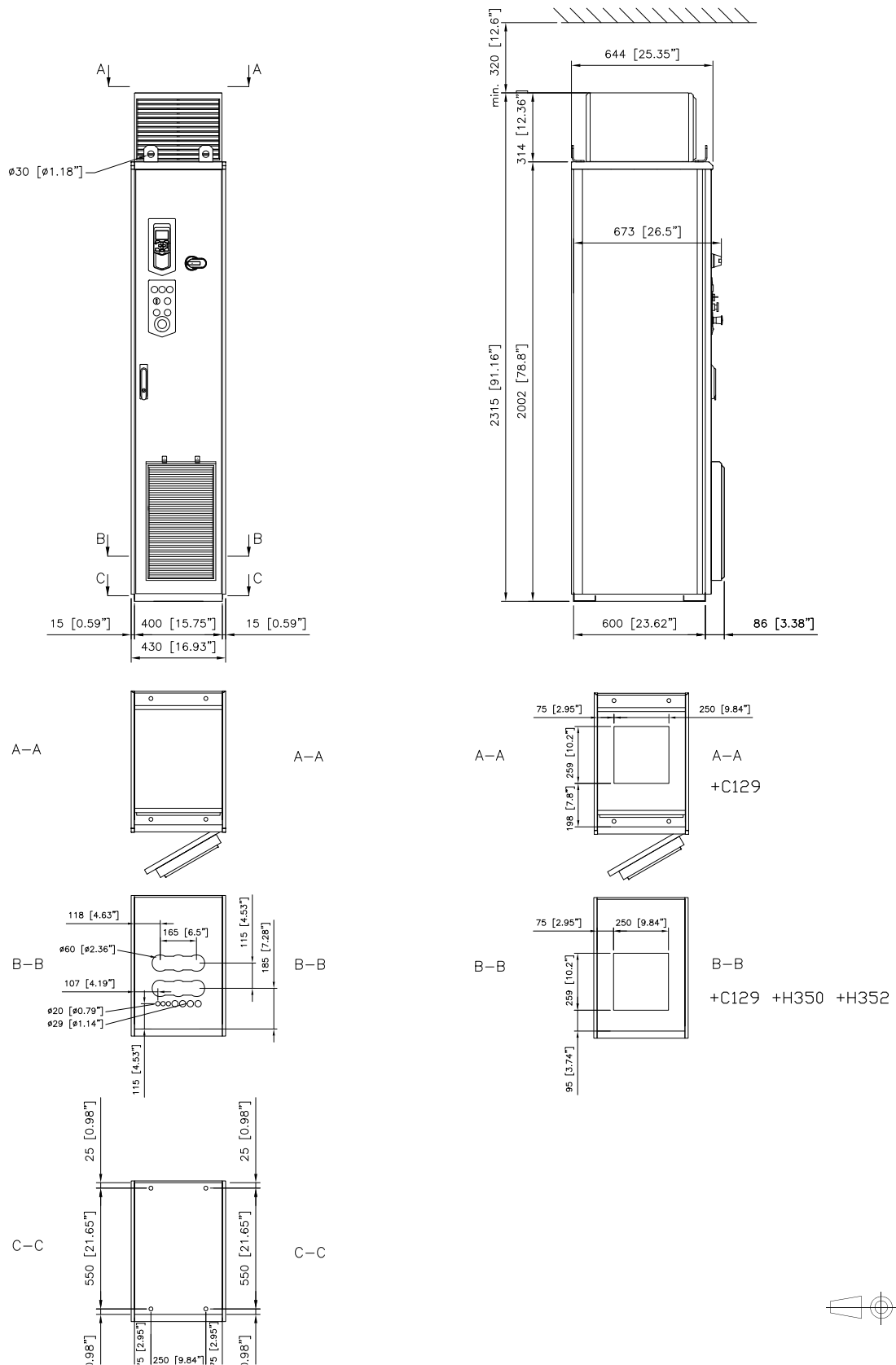

Frame R9 (IP22 and IP42 [+B054], UL Type 1) – standard and options +C129, +H350, +H352

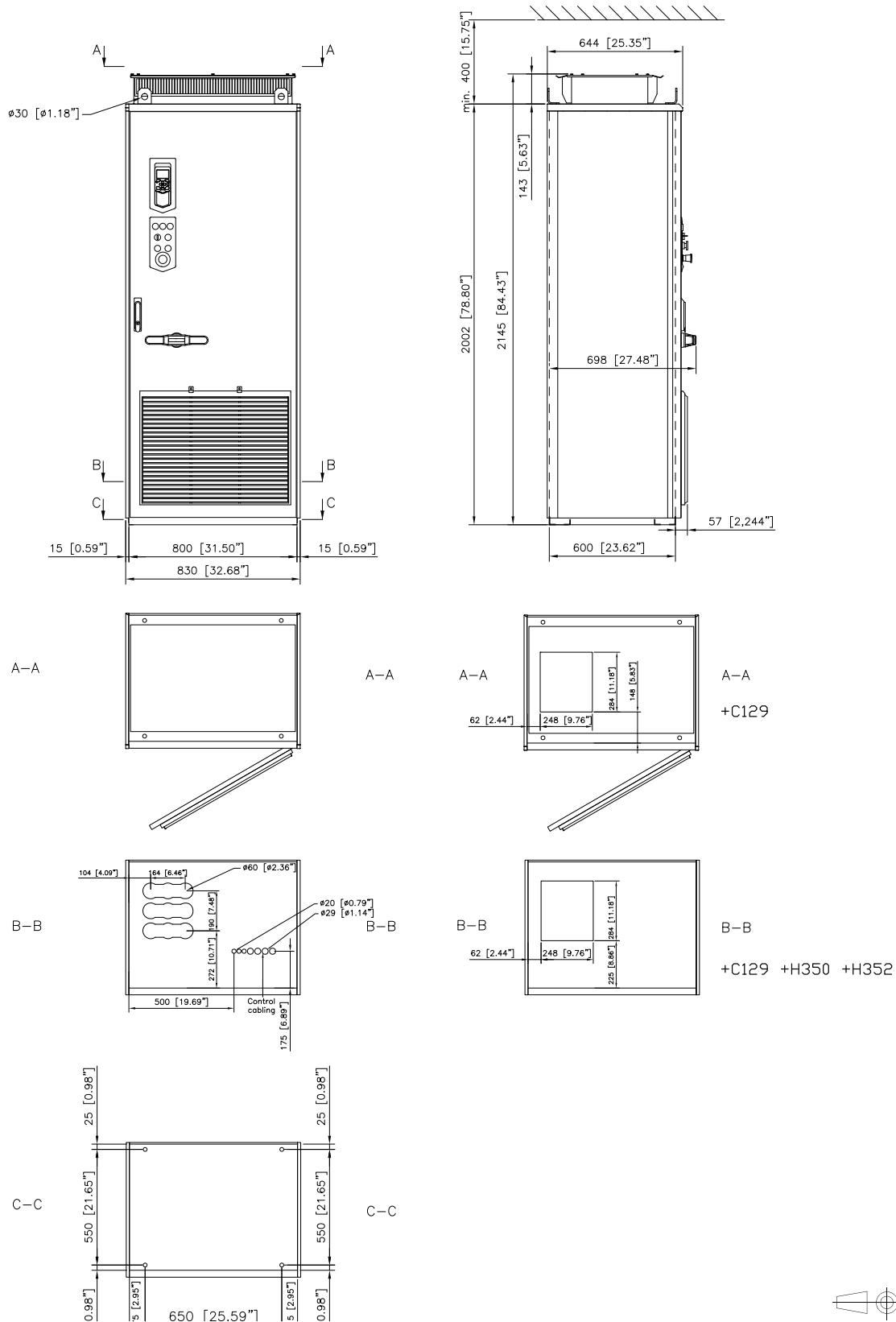

Frame R9 (IP54 / UL Type 12 [+B055]) – standard and options +C129, +H350, +H352

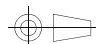
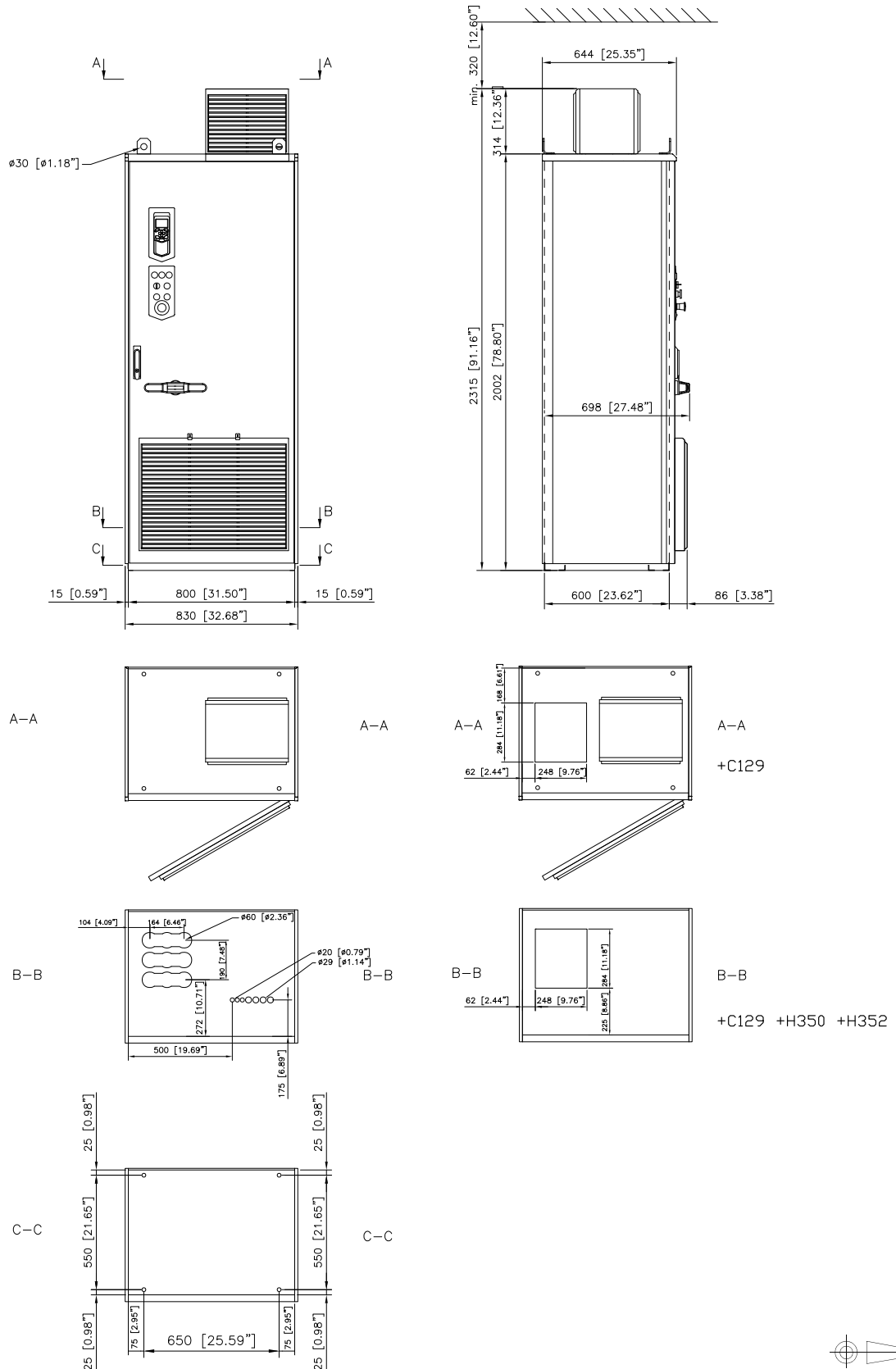

Frame R9 marine (option +C121) – standard and options +C129, +H350, +H352

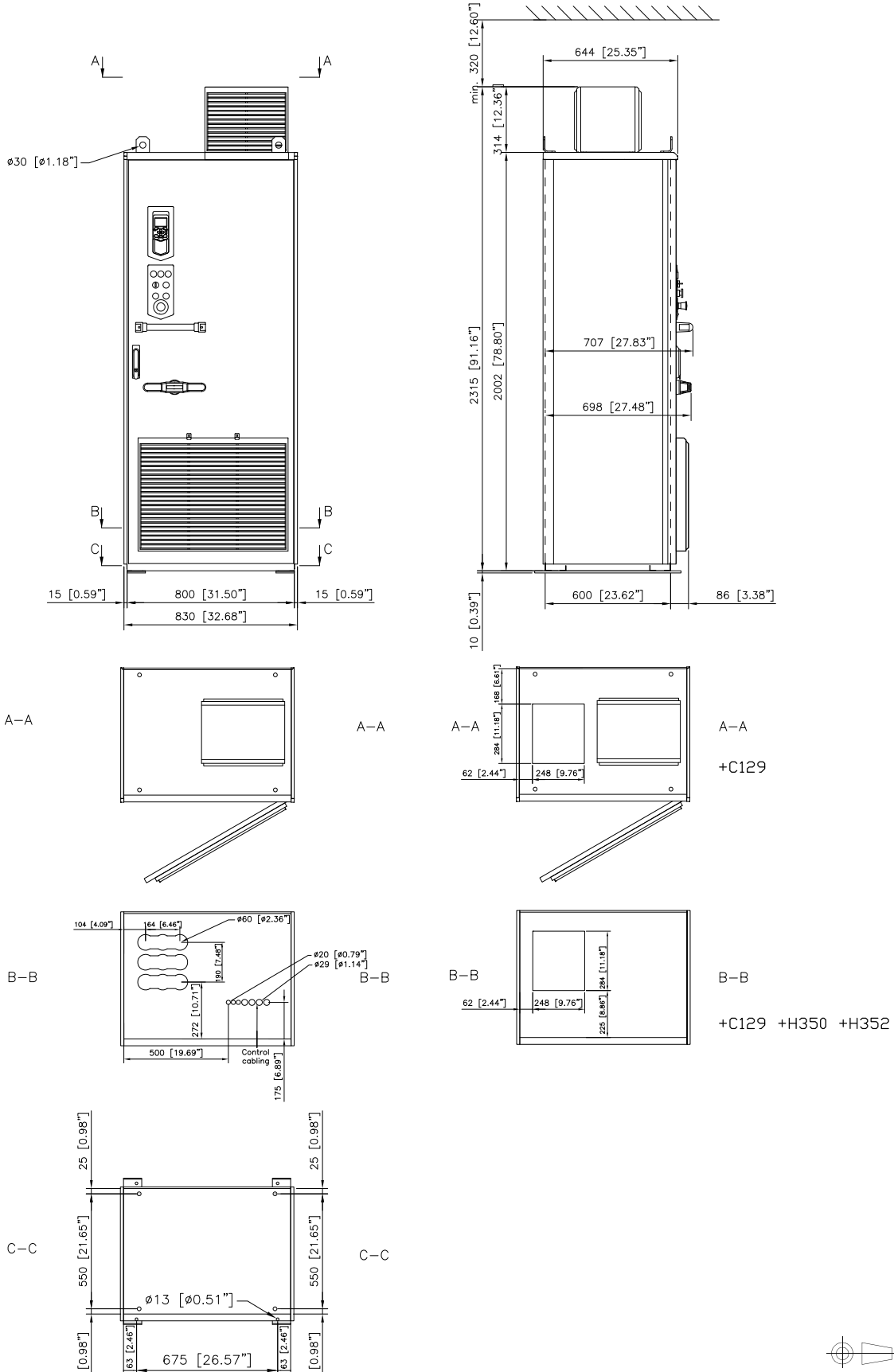

Frames R6 to R8 with options +F289, +C129, +H350, +H352 (UL Type 1)

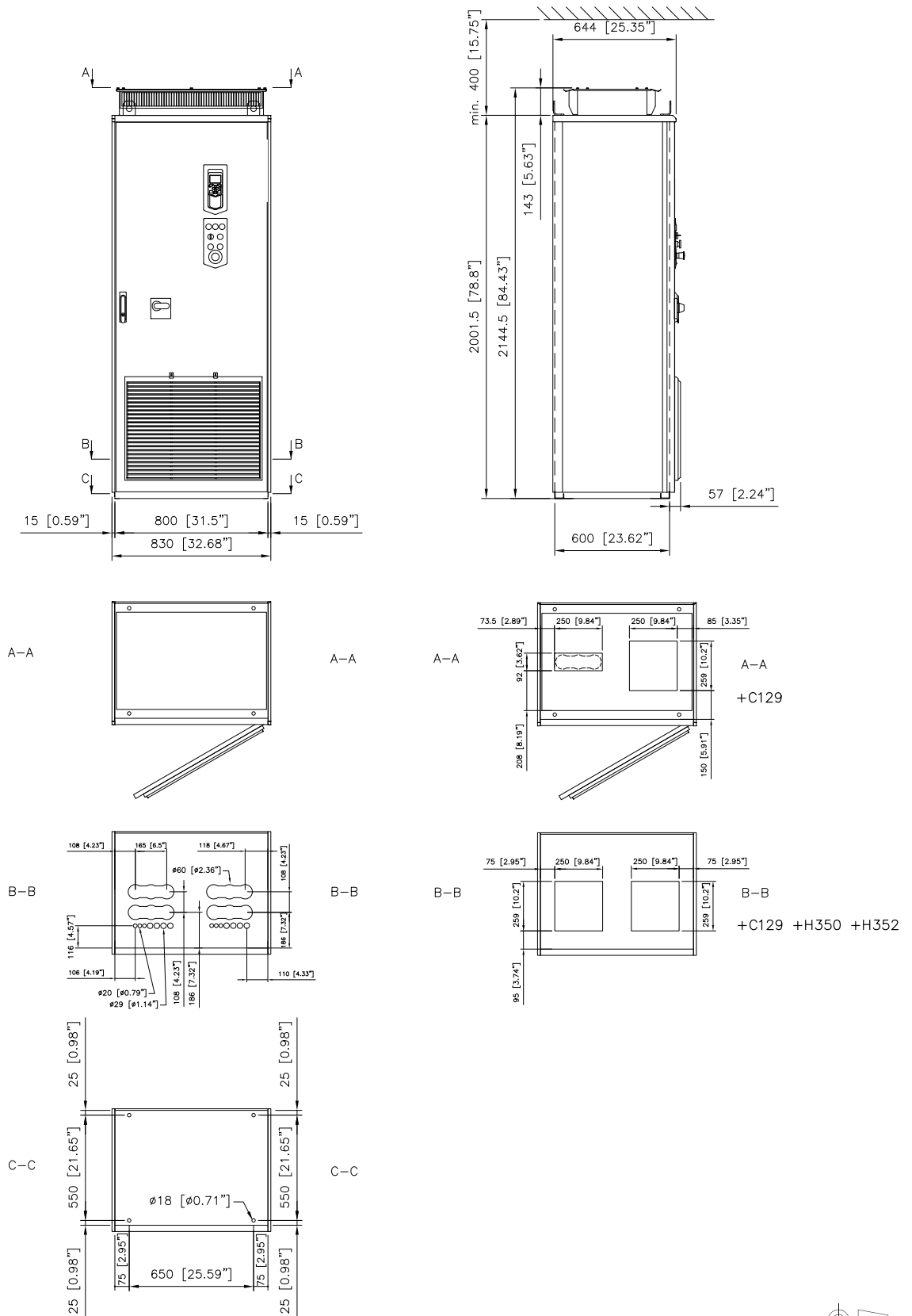

Frames R6 to R8 with options +F289, +C129, +H350, +H352 (UL Type 12 [+B055])

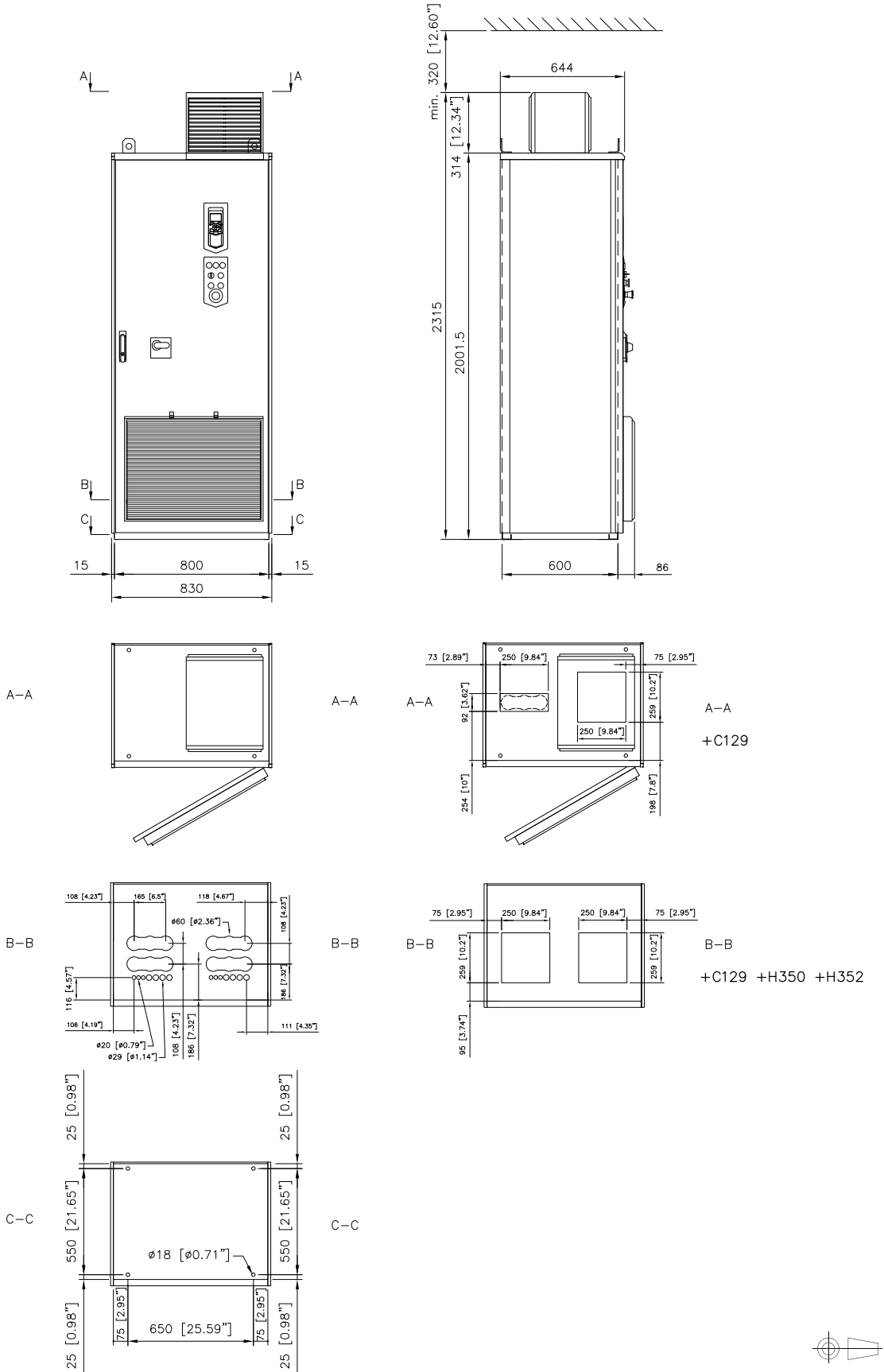

Frames R10 and R11 (IP54 / UL Type 12) – standard and options +C129, +H350, +H352

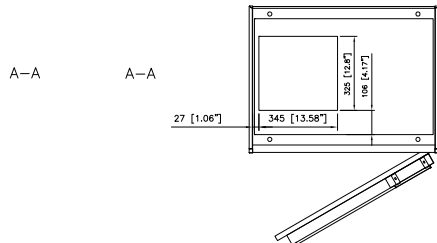
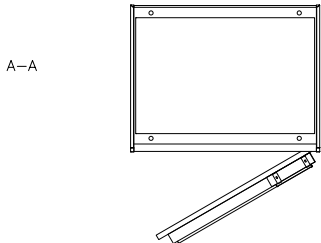
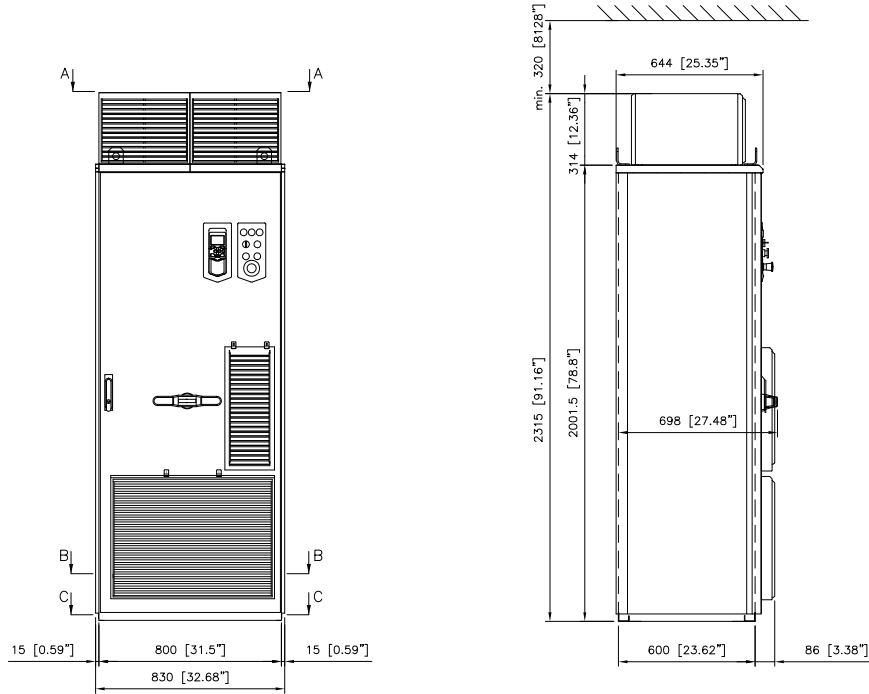

A-A
+C129

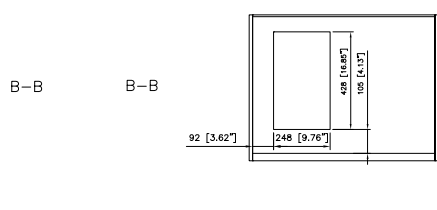
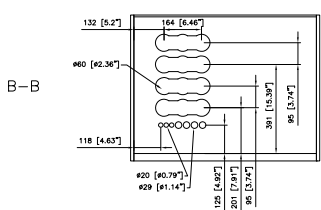

B-B
+C129 +H350 +H352

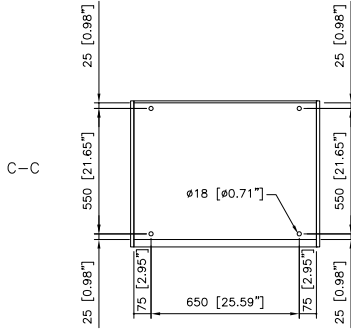

C-C

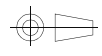

Frames R10 and R11 (options +C129+F277+F289)

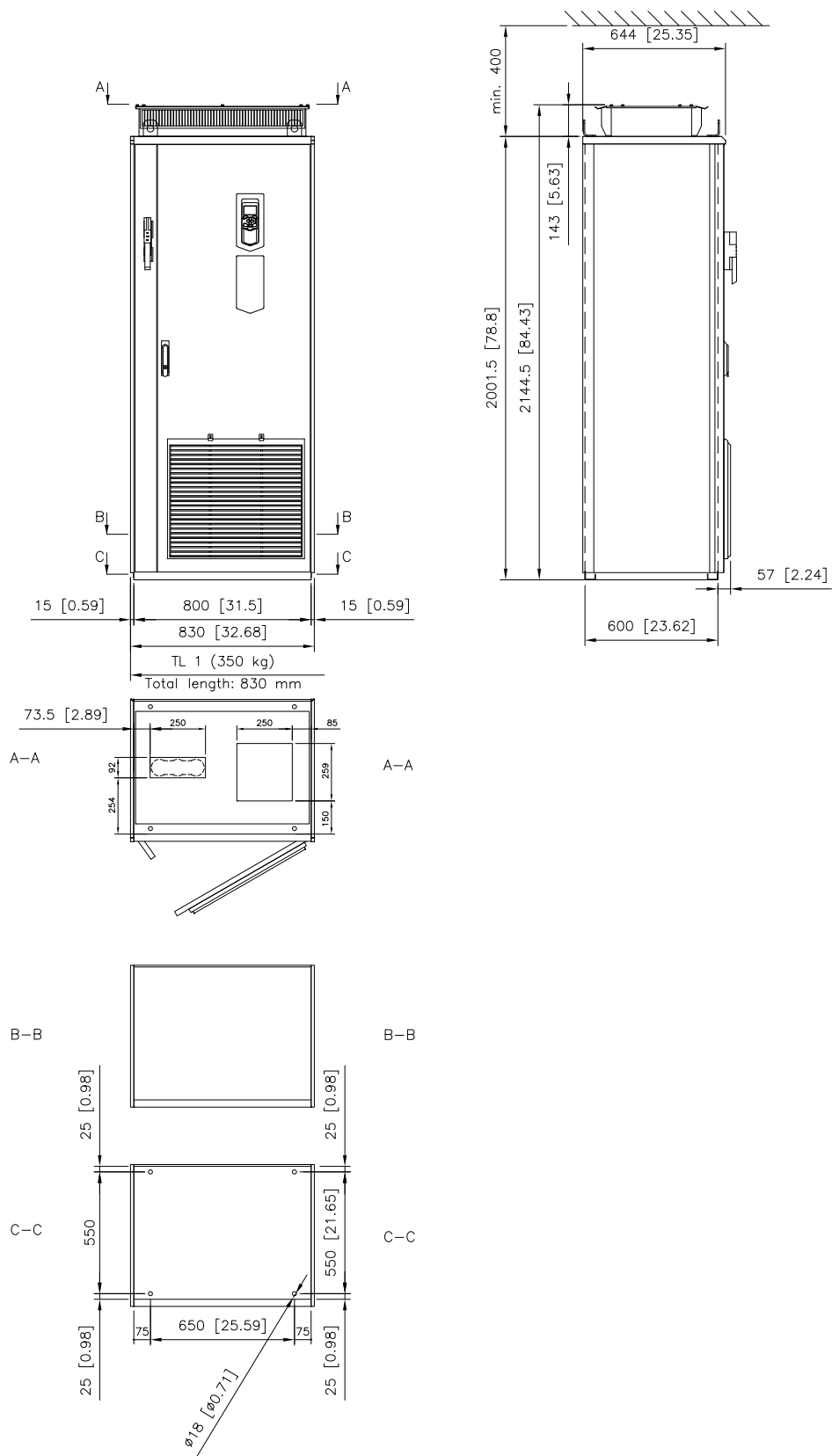

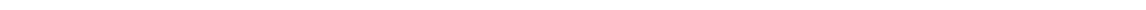

15

Safe torque off function

Contents of this chapter

This chapter describes the Safe torque off function of the drive and gives instructions for its use.

Description

The Safe torque off function can be used, for example, to construct safety or supervision circuits that stop the drive in case of danger (such as an emergency stop circuit). Another possible application is a service switch that enables short-time maintenance operations like cleaning or work on non-electrical parts of the machinery without switching off the power supply to the drive.

When activated, the Safe torque off function disables the control voltage of the power semiconductors of the drive output stage (A, see diagram below), thus preventing the drive from generating the torque required to rotate the motor. If the motor is running when Safe torque off is activated, it coasts to a stop.

The Safe torque off function has a redundant architecture, that is, both channels must be used in the safety function implementation. The safety data given in this manual is calculated for redundant use, and does not apply if both channels are not used.

The Safe torque off function of the drive complies with these standards:

Standard	Name
EN 60204-1:2006 + AC:2010	<i>Safety of machinery – Electrical equipment of machines – Part 1: General requirements</i>
IEC 61326-3-1:2008	<i>Electrical equipment for measurement, control and laboratory use – EMC requirements – Part 3-1: Immunity requirements for safety-related systems and for equipment intended to perform safety-related functions (functional safety) – General industrial applications</i>

Standard	Name
IEC 61508-1:2010	<i>Functional safety of electrical/electronic/programmable electronic safety-related systems – Part 1: General requirements</i>
IEC 61508-2:2010	<i>Functional safety of electrical/electronic/programmable electronic safety-related systems – Part 2: Requirements for electrical/electronic/programmable electronic safety-related systems</i>
IEC 61511:2003	<i>Functional safety – Safety instrumented systems for the process industry sector</i>
IEC/EN 61800-5-2:2007	<i>Adjustable speed electrical power drive systems – Part 5-2: Safety requirements – Functional</i>
EN 62061:2005 + A1:2013 IEC 62061:2005 + A1:2012	<i>Safety of machinery – Functional safety of safety-related electrical, electronic and programmable electronic control systems</i>
EN ISO 13849-1:2008 + AC:2009	<i>Safety of machinery – Safety-related parts of control systems – Part 1: General principles for design</i>
EN ISO 13849-2:2012	<i>Safety of machinery – Safety-related parts of control systems – Part 2: Validation</i>

The function also corresponds to prevention of unexpected start-up as specified by EN 1037:1995 + A1:2008 and uncontrolled stop (stop category 0) as specified in EN 60204-1:2006 + AC:2010.

■ Compliance with the European Machinery Directive

See section [Compliance with the European Machinery Directive](#) on page 209.

Wiring

The following diagrams show examples of Safe torque off wiring for

- a single drive (page 231)
- multiple drives (page 232)
- multiple drives when an external 24 V DC power supply is used (page 233).

For information on the specifications of the STO input, see section [Safe torque off \(XSTO\)](#) on page 131.

■ Activation switch

In the wiring diagrams below, the activation switch has the designation (K). This represents a component such as a manually operated switch, an emergency stop push button switch, or the contacts of a safety relay or safety PLC.

- If a manually operated activation switch is used, the switch must be of a type that can be locked out to the open position.
- The contacts of the switch or relay must open/close within 200 ms of each other.
- An FSO-xx safety functions module can also be used. For more information, see the FSO-xx module documentation.

■ Cable types and lengths

We recommend double-shielded twisted-pair cable.

Maximum cable lengths:

- 300 m (984 ft) between activation switch (K) and drive control unit
- 60 m (200 ft) between multiple drives
- 60 m (200 ft) between external power supply and first drive.

Note that the voltage at the INx terminals of each drive must be at least 17 V DC to be interpreted as “1”.

■ Grounding of protective shields

- Ground the shield in the cabling between the activation switch and the control unit at the control unit.
- Ground the shield in the cabling between two control units at one control unit only.

■ Single drive (internal power supply)

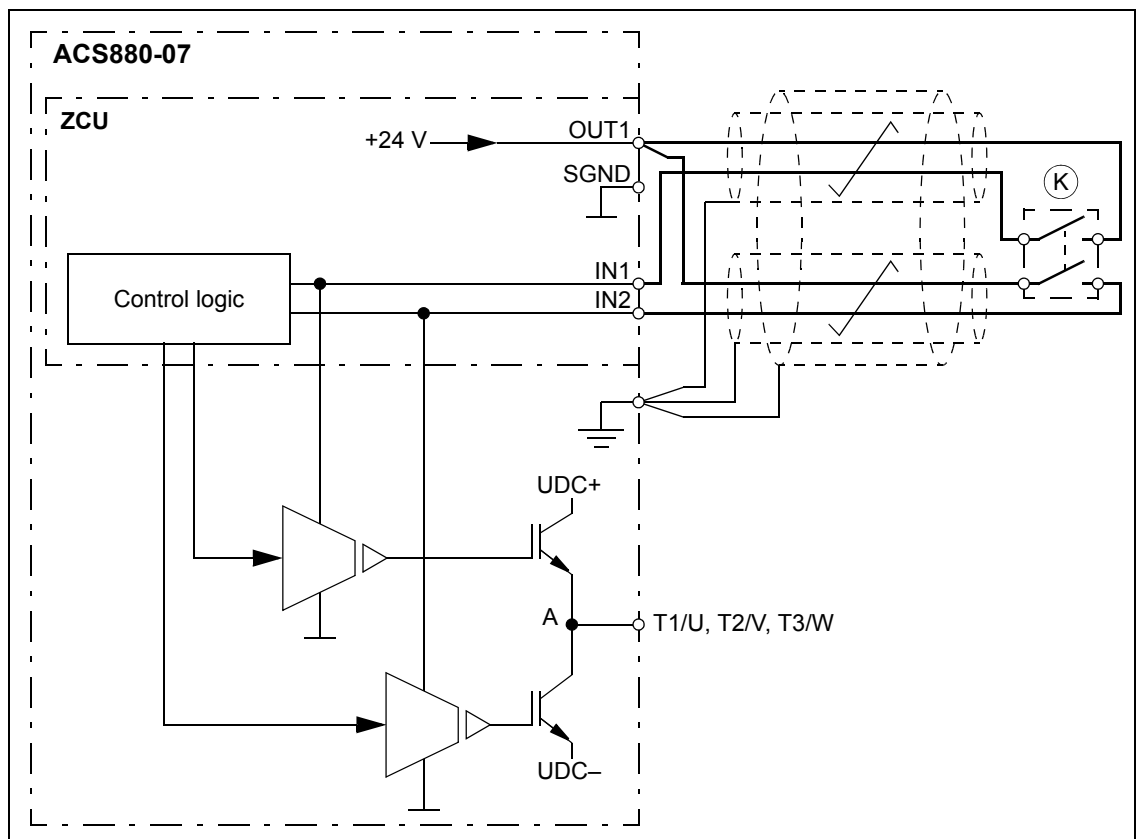

■ Multiple drives (internal power supply)

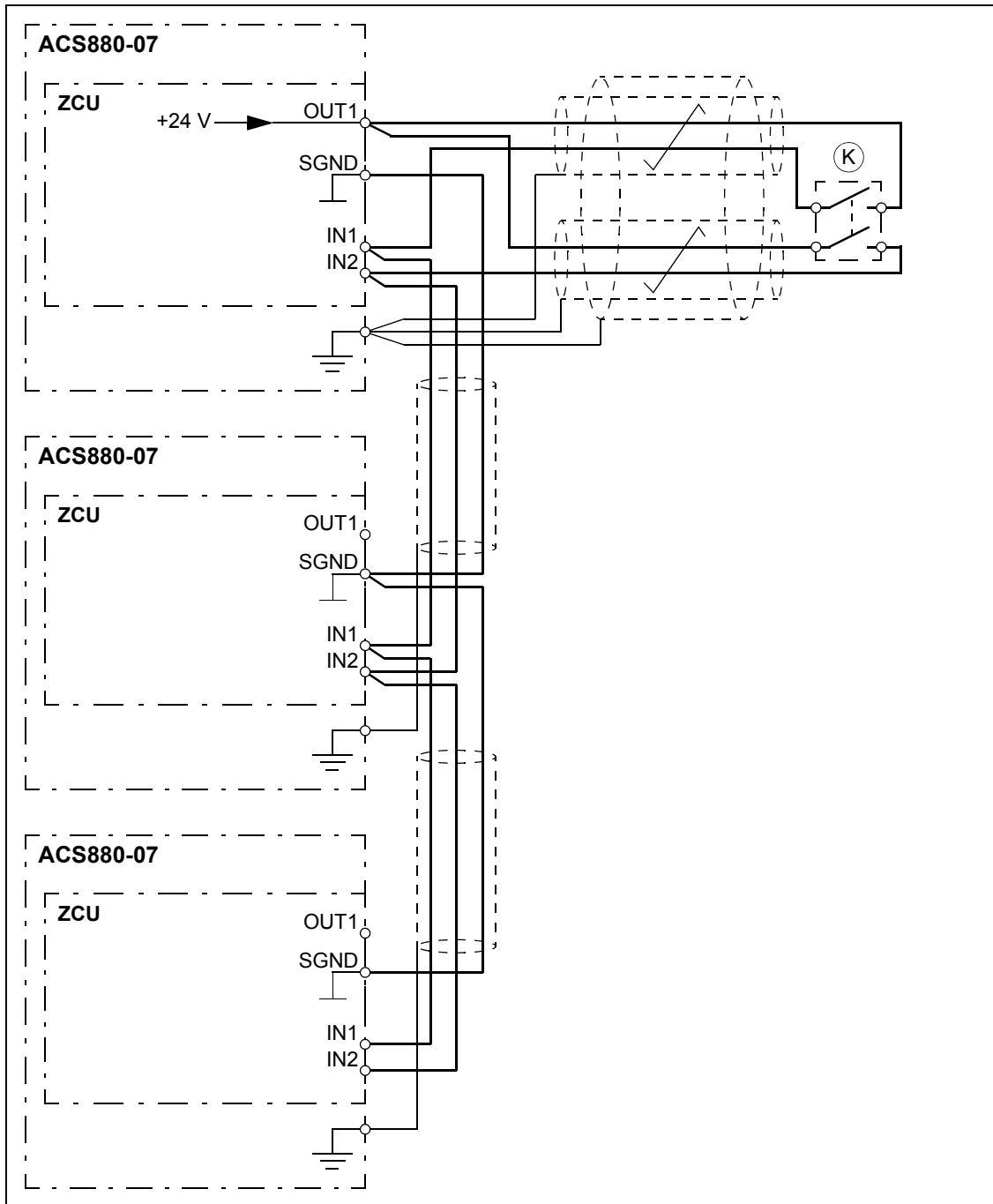

■ Multiple drives (external power supply)

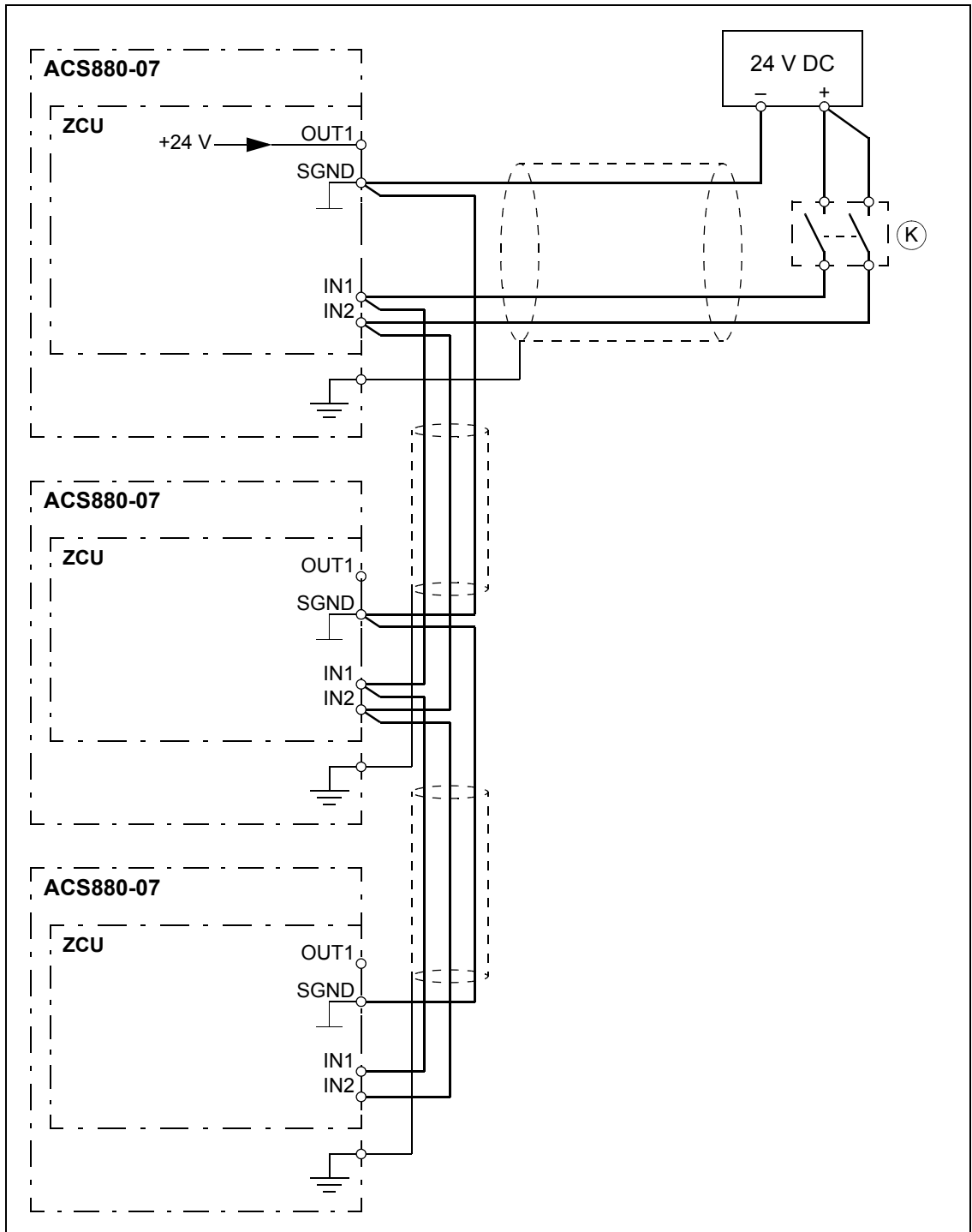

Operation principle

1. The Safe torque off activates (the activation switch is opened, or safety relay contacts open).
2. STO inputs on the drive control unit de-energize.
3. The control unit cuts off the control voltage from the drive IGBTs.
4. The control program generates an indication as defined by parameter 31.22 (refer to the firmware manual of the drive).
5. Motor coasts to stop (if running). The drive cannot restart while the activation switch or safety relay contacts are open. After the contacts close, a new start command is required to start the drive.

Start-up including acceptance test

To ensure safe operation of the Safe torque off function, validation is required. The final assembler of the machine must validate the function by performing an acceptance test.

The acceptance test must be performed:

- at initial start-up of the safety function
- after any changes related to the safety function (circuit boards, wiring, components, settings, etc.)
- after any maintenance work related to the safety function.

Competence

The acceptance test of the safety function must be carried out by a competent person with adequate expertise and knowledge of the safety function as well as functional safety, as required by IEC 61508-1 clause 6. The test procedures and report must be documented and signed by this person.

Acceptance test reports

Signed acceptance test reports must be stored in the logbook of the machine. The report shall include documentation of start-up activities and test results, references to failure reports and resolution of failures. Any new acceptance tests performed due to changes or maintenance shall be logged into the logbook.

Acceptance test procedure

After wiring the Safe torque off function, validate its operation as follows. If the drive is equipped with safety option +Q950, +Q951, +Q952, +Q957, +Q963, +Q964, +Q978 or +Q979, do the procedure shown in the documentation of the option. If the drive is equipped with safety option Q973, do the procedure shown in the FSO module documentation.

Action	<input checked="" type="checkbox"/>
 WARNING! Follow the Safety instructions , page 13. Ignoring the instructions can cause physical injury or death, or damage to the equipment.	<input type="checkbox"/>
Make sure that the drive can be run and stopped freely during start-up.	<input type="checkbox"/>
Stop the drive (if running), switch the input power off and isolate the drive from the power line by a disconnecter.	<input type="checkbox"/>

Action	<input checked="" type="checkbox"/>
Check the Safe torque off (STO) circuit connections against the wiring diagram.	<input type="checkbox"/>
Close the disconnecter and switch the power on.	<input type="checkbox"/>
<p>Test the operation of the STO function when the motor is stopped.</p> <ul style="list-style-type: none"> • Give a stop command for the drive (if running) and wait until the motor shaft is at a standstill. <p>Make sure that the drive operates as follows:</p> <ul style="list-style-type: none"> • Open the STO circuit. The drive generates an indication if one is defined for 'stopped' state in parameter 31.22 (see the firmware manual). • Give a start command to verify that the STO function blocks the drive operations. The motor should not start. • Close the STO circuit. • Reset any active faults. Restart the drive and check that the motor runs normally. 	<input type="checkbox"/>
<p>Test the operation of the STO function when the motor is running:</p> <ul style="list-style-type: none"> • Start the drive and make sure the motor is running. • Open the STO circuit. The motor should stop. The drive generates an indication if one is defined for 'running' state in parameter 31.22 (see the firmware manual). • Reset any active faults and try to start the drive. • Make sure that the motor stays at standstill and the drive operates as described above in testing the operation when the motor is stopped. • Close the STO circuit. • Reset any active faults. Restart the drive and check that the motor runs normally. 	<input type="checkbox"/>
Document and sign the acceptance test report which verifies that the safety function is safe and accepted for operation.	<input type="checkbox"/>

Use

1. Open the activation switch, or activate the safety functionality that is wired to the STO connection.
2. STO inputs on the drive control unit de-energize, and the drive control unit cuts off the control voltage from the inverter IGBTs.
3. The control program generates an indication as defined by parameter 31.22 (refer to the firmware manual of the drive).
4. Motor coasts to stop (if running). The drive will not restart while the activation switch or safety relay contacts are open.
5. Deactivate the STO by closing the activation switch, or resetting the safety functionality that is wired to the STO connection.
6. Reset any faults before restarting.



WARNING! The Safe torque off function does not disconnect the voltage of the main and auxiliary circuits from the drive. Therefore maintenance work on electrical parts of the drive or the motor can only be carried out after isolating the drive system from the main supply.



WARNING! (With permanent magnet or synchronous reluctance [SynRM] motors only) In case of a multiple IGBT power semiconductor failure, the drive system can produce an alignment torque which maximally rotates the motor shaft by $180/p$ (with permanent magnet motors) or $180/2p$ (with synchronous reluctance [SynRM])

motors) degrees regardless of the activation of the Safe torque off function. p denotes the number of pole pairs.

Notes:

- If a running drive is stopped by using the Safe torque off function, the drive will cut off the motor supply voltage and the motor will coast to a stop. If this causes danger or is not otherwise acceptable, stop the drive and machinery using the appropriate stop mode before activating the Safe torque off function.
- The Safe torque off function overrides all other functions of the drive.
- The Safe torque off function is ineffective against deliberate sabotage or misuse.
- The Safe torque off function has been designed to reduce the recognized hazardous conditions. In spite of this, it is not always possible to eliminate all potential hazards. The assembler of the machine must inform the final user about the residual risks.

Maintenance

the STO function shall be maintained by periodic proof testing. In high demand mode of operation, the maximum proof test interval is 20 years. In low demand mode of operation, the maximum proof test interval is 2 years. The test procedure is given in section [Acceptance test procedure](#) (page 234).

Note: See also the Recommendation of Use CNB/M/11.050 (published by the European co-ordination of Notified Bodies) concerning dual-channel safety-related systems with electromechanical outputs:

- When the safety integrity requirement for the safety function is SIL 3 or PL e (cat. 3 or 4), the proof test for the function must be performed at least every month.
- When the safety integrity requirement for the safety function is SIL 2 (HFT = 1) or PL d (cat. 3), the proof test for the function must be performed at least every 12 months.

The STO function of the drive does not contain any electromechanical components.

In addition to proof testing, it is a good practice to check the operation of the function when other maintenance procedures are carried out on the machinery.

Include the Safe torque off operation test described above in the routine maintenance program of the machinery that the inverter runs.

If any wiring or component change is needed after start up, or the parameters are restored, follow the test given in section [Acceptance test procedure](#) page 234.

Use only ABB approved spare parts.

Record all maintenance and proof test activities in the machine logbook.

■ Competence

The maintenance and proof test activities of the safety function must be carried out by a competent person with adequate expertise and knowledge of the safety function as well as functional safety, as required by IEC 61508-1 clause 6.

Fault tracing

The indications given during the normal operation of the Safe torque off function are selected by drive parameter 31.22.

The diagnostics of the Safe torque off function cross-compare the status of the two STO channels. In case the channels are not in the same state, a fault reaction function is

performed and the drive trips on an “STO hardware failure” fault. An attempt to use the STO in a non-redundant manner, for example activating only one channel, will trigger the same reaction.

See the drive firmware manual for the indications generated by the drive, and for details on directing fault and warning indications to an output on the control unit for external diagnostics.

Any failures of the Safe torque off function must be reported to ABB.

Safety data (SIL, PL)

The safety data for the Safe torque off function is given below.

Frame	SIL/ SILCL	SC	PL	SFF (%)	PFH ($T_1 = 20$ a) (1/h)	PFd ($T_1 = 2$ a)	MTTF _d (a)	DC* (%)	Cat.	HFT	CCF (%)	Lifetime (a)
$U_1 = 380 \dots 500$ V												
R6	3	3	e	99.65	2.44E-09 (2.44 FIT)	8.70E-7	3847	≥ 90	3	1	80	20
R7	3	3	e	99.65	2.44E-09 (2.44 FIT)	8.70E-7	3847	≥ 90	3	1	80	20
R8	3	3	e	95.04	3.84E-09 (3.84 FIT)	1.56E-4	1374	≥ 90	3	1	80	20
R9	3	3	e	95.04	3.84E-09 (3.84 FIT)	1.56E-4	1374	≥ 90	3	1	80	20
R10	3	3	e	99.63	3.91E-09 (3.91 FIT)	3.43E-5	18774	≥ 90	3	1	80	20
R11	3	3	e	99.63	3.91E-09 (3.91 FIT)	3.43E-5	18774	≥ 90	3	1	80	20
$U_1 = 525 \dots 690$ V												
R6 to R9	3	3	e	95.04	3.84E-09 (3.84 FIT)	1.56E-4	1374	≥ 90	3	1	80	20
R10, R11	3	3	e	99.85	6.60E-09	4.89E-05	428.32	≥ 99	3	1	80	20

* according to Table E.1 in EN/ISO 13849-1

- This temperature profile is used in safety value calculations:
 - 670 on/off cycles per year with $\Delta T = 71.66$ °C
 - 1340 on/off cycles per year with $\Delta T = 61.66$ °C
 - 30 on/off cycles per year with $\Delta T = 10.0$ °C
 - 32 °C board temperature at 2.0% of time
 - 60 °C board temperature at 1.5% of time
 - 85 °C board temperature at 2.3% of time.
- The safety data is calculated for redundant use, and does not apply if both channels are not used.
- The STO is a type A safety component as defined in IEC 61508-2.
- Relevant failure modes:
 - The STO trips spuriously (safe failure)
 - The STO does not activate when requested

A fault exclusion on the failure mode “short circuit on printed circuit board” has been made (EN 13849-2, table D.5). The analysis is based on an assumption that one failure occurs at one time. No accumulated failures have been analyzed.

- STO reaction time (shortest detectable break): 1 ms
- STO response time: 2 ms (typical), 5 ms (maximum)
- Fault detection time: Channels in different states for longer than 200 ms
- Fault reaction time: Fault detection time + 10 ms
- STO fault indication (parameter 31.22) delay: < 500 ms
- STO warning indication (parameter 31.22) delay: < 1000 ms

■ Abbreviations

Abbr.	Reference	Description
Cat.	EN ISO 13849-1	Classification of the safety-related parts of a control system in respect of their resistance to faults and their subsequent behavior in the fault condition, and which is achieved by the structural arrangement of the parts, fault detection and/or by their reliability. The categories are: B, 1, 2, 3 and 4.
CCF	EN ISO 13849-1	Common cause failure (%)
DC	EN ISO 13849-1	Diagnostic coverage
FIT	IEC 61508	Failure in time: 1E-9 hours
HFT	IEC 61508	Hardware fault tolerance
MTTF _d	EN ISO 13849-1	Mean time to dangerous failure: (The total number of life units) / (the number of dangerous, undetected failures) during a particular measurement interval under stated conditions
PFD	IEC 61508	Probability of failure on demand
PFH	IEC 61508	Probability of dangerous failures per hour
PL	EN ISO 13849-1	Performance level. Levels a...e correspond to SIL
SC	IEC 61508	Systematic capability
SFF	IEC 61508	Safe failure fraction (%)
SIL	IEC 61508	Safety integrity level (1...3)
SILCL	IEC/EN 62061	Maximum SIL (level 1...3) that can be claimed for a safety function or subsystem
SS1	IEC/EN 61800-5-2	Safe stop 1
STO	IEC/EN 61800-5-2	Safe torque off
T1	IEC 61508-6	Proof test interval. T1 is a parameter used to define the probabilistic failure rate (PFH or PFD) for the safety function or subsystem. Performing a proof test at a maximum interval of T1 is required to keep the SIL capability valid. The same interval must be followed to keep the PL capability (EN ISO 13849) valid. Note that any T1 values given cannot be regarded as a guarantee or warranty. See also section Maintenance (page 149).

16

Resistor braking

Contents of this chapter

This chapter tells how to select, protect and wire brake choppers and resistors. The chapter also contains the technical data.

Operation principle and hardware description

The drive can be equipped with optional built-in brake chopper (+D150). Brake resistors are available as add-on kits or factory installed (+D151).

The brake chopper handles the energy generated by a decelerating motor. The chopper connects the brake resistor to the intermediate DC circuit whenever the voltage in the circuit exceeds the limit defined by the control program. Energy consumption by the resistor losses lowers the voltage until the resistor can be disconnected.

Planning the braking system

■ Selecting the brake circuit components

1. Calculate the maximum power generated by the motor during braking (P_{max}).
2. Select a suitable drive, brake chopper and brake resistor combination for the application from the rating table on page 243. The braking power of the chopper must be greater or equal than the maximum power generated by the motor during the braking.
3. Check the resistor selection. The energy generated by the motor during a 400-second period must not exceed the resistor heat dissipation capacity E_R .

Note: If the E_R value is not sufficient, it is possible to use a four-resistor assembly in which two standard resistors are connected in parallel, two in series. The E_R value of the four-resistor assembly is four times the value specified for the standard resistor.

■ Selecting a custom resistor

If you use a resistor other than the default resistor, make sure that:

1. The resistance of the custom resistor is greater or equal than the resistance of the default resistor in the rating table on page 243:

$$R \geq R_{\min}$$

where

R Resistance of the custom resistor.



WARNING! Never use a brake resistor with a resistance smaller than R_{\min} . The drive and the chopper are not able to handle the overcurrent caused by the low resistance.

R_{\min} Resistance of the default resistor

2. The load capacity of the custom resistor is higher than the instantaneous maximum power consumption of the resistor when it is connected to the drive DC link voltage by the chopper:

$$P_r > \frac{U_{DC}^2}{R}$$

where

P_r Load capacity of the custom resistor

U_{DC} Drive DC link voltage.

1.35 · 1.25 · 415 V DC (when supply voltage is 380 to 415 V AC)

1.35 · 1.25 · 500 V DC (when supply voltage is 440 to 500 V AC) or

1.35 · 1.25 · 690 V DC (when supply voltage is 525 to 690 AC)

R Resistance of the custom resistor

■ Selecting and routing the external brake resistor cables

Use the same cable type for the resistor cabling as for the drive input cabling to ensure that the input fuses also protect the resistor cable. Alternatively, a two conductor shielded cable with the same cross-sectional area can be used.

Minimizing electromagnetic interference

Follow these rules in order to minimize electromagnetic interference caused by the rapid current changes in the resistor cables:

- Shield the braking power line completely, either by using shielded cable or a metallic enclosure. Unshielded single-core cable can only be used if it is routed inside a cabinet that efficiently suppresses the radiated emissions.
 - Install the cables away from other cable routes.
 - Avoid long parallel runs with other cables. The minimum parallel cabling separation distance should be 0.3 meters.
 - Cross the other cables at right angles.
 - Keep the cable as short as possible in order to minimize the radiated emissions and stress on chopper IGBTs. The longer the cable the higher the radiated emissions, inductive load and voltage peaks over the IGBT semiconductors of the brake chopper.
-

Maximum cable length

The maximum length of the resistor cable(s) is 10 m (33 ft).

EMC compliance of the complete installation

Note: ABB has not verified that the EMC requirements are fulfilled with external user-defined brake resistors and cabling. The EMC compliance of the complete installation must be considered by the customer.

Placing the brake resistors

Install the resistors outside the drive in a place where they will cool.

Arrange the cooling of the resistor in a way that:

- no danger of overheating is caused to the resistor or nearby materials
- the temperature of the room the resistor is located in does not exceed the allowed maximum.

Supply the resistor with cooling air/water according to the resistor manufacturer's instructions.



WARNING! The materials near the brake resistor must be non-flammable. The surface temperature of the resistor is high. Air flowing from the resistor is of hundreds of degrees Celsius. If the exhaust vents are connected to a ventilation system, ensure that the material withstands high temperatures. Protect the resistor against contact.

■ Protecting the system against thermal overload

The brake chopper protects itself and the resistor cables against thermal overload when the cables are dimensioned according to the nominal current of the drive. The drive control program includes a resistor and resistor cable thermal protection function which can be tuned by the user. See the firmware manual.

A main contactor is not required for protecting against resistor overheating when the resistor is dimensioned according to the instructions and the internal brake chopper is in use. The drive will disable power flow through the input bridge if the chopper remains conductive in a fault situation but the charging resistor may fail.

Note: If an external brake chopper (outside the drive module) is used, a main contactor is always required.

A thermal switch (standard in ABB resistors) is required for safety reasons. The thermal switch cable must be shielded and may not be longer than the resistor cable. Wire the switch to a digital input on the drive control unit as shown in the figure below.

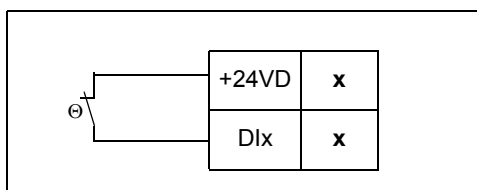

■ Protecting the resistor cable against short-circuits

The input fuses will also protect the resistor cable when it is identical with the input cable.

Mechanical installation of external brake resistors

All brake resistors must be installed outside the drive. Follow the resistor manufacturer's instructions.

Electrical installation

■ Checking the insulation of the assembly

Follow the instructions given under [Brake resistor assembly](#) on page 94.

■ Connection diagram

See section [Connection diagram](#) on page 96.

■ Connection procedure

- Connect the resistor cables to the R+ and R- terminals in the same way as the other power cables. If a shielded three-conductor cable is used, cut the third conductor and ground the twisted shield of the cable (protective earth conductor of the resistor assembly) at both ends.
- Connect the thermal switch of the brake resistor as described in section [Protecting the system against thermal overload](#) on page 241.

Start-up

Note: Protective oil on the brake resistors will burn off when the brake resistor is used for the first time. Make sure that the airflow is sufficient.

Set the following parameters (ACS880 primary control program):

- Disable the overvoltage control of the drive by parameter **30.30 Overvoltage control**.
- Set parameter **31.01 External event 1 source** to point to the digital input where the thermal switch of the brake resistor is wired.
- Set parameter **31.02 External event 1 type** to **Fault**.
- Enable the brake chopper by parameter **43.06 Brake chopper enable**. If **Enabled with thermal model** is selected, set also the brake resistor overload protection parameters 43.08 and 43.09 according to the application.
- Set parameter **43.07 Brake chopper runtime enable** to **Other [bit]** and select from parameter **10.01 DI status** the digital input where the thermal switch of the brake resistor is wired.
- Check the resistance value of parameter **43.10 Brake resistance**.
- With these parameter settings, the drive stops by coasting on brake resistor overtemperature.



WARNING! If the drive is equipped with a brake chopper but the chopper is not enabled by the parameter setting, the internal thermal protection of the drive against resistor overheating is not in use. In this case, the brake resistor must be disconnected.

For settings of other control programs, see the appropriate firmware manual.

Technical data

■ Ratings

Drive type	Internal brake chopper		Example brake resistor(s)			
	P_{brcont}	R_{min}	Type	R	E_R	P_{Rcont}
	kW	ohm		ohm	kJ	kW
$U_N = 400\text{ V}$						
ACS880-07-0105A-3	55	5.4	SAFUR80F500	6	2400	6
ACS880-07-0145A-3	75	5.4	SAFUR80F500	6	2400	6
ACS880-07-0169A-3	90	3.3	SAFUR125F500	4	3600	9
ACS880-07-0206A-3	110	3.3	SAFUR125F500	4	3600	9
ACS880-07-0246A-3	132	2.3	SAFUR200F500	2.7	5400	13.5
ACS880-07-0293A-3	132	2.3	SAFUR200F500	2.7	5400	13.5
ACS880-07-0363A-3	160	2.0	SAFUR200F500	2.7	5400	13.5
ACS880-07-0430A-3	160	2.0	SAFUR200F500	2.7	5400	13.5
ACS880-07-0505A-3	250	2.0	2×SAFUR125F500	2.00	7200	18
ACS880-07-0585A-3	315	1.3	2×SAFUR200F500	1.35	10800	27
ACS880-07-0650A-3	315	1.3	2×SAFUR200F500	1.35	10800	27
ACS880-07-0725A-3	400	0.7	3×SAFUR200F500	0.90	16200	40
ACS880-07-0820A-3	400	0.7	3×SAFUR200F500	0.90	16200	40
ACS880-07-0880A-3	400	0.7	3×SAFUR200F500	0.90	16200	40
$U_N = 500\text{ V}$						
ACS880-07-0096A-5	55	5.4	SAFUR80F500	6	2400	6
ACS880-07-0124A-5	75	5.4	SAFUR80F500	6	2400	6
ACS880-07-0156A-5	90	3.3	SAFUR125F500	4	3600	9
ACS880-07-0180A-5	110	3.3	SAFUR125F500	4	3600	9
ACS880-07-0240A-5	132	2.3	SAFUR200F500	2.7	5400	13.5
ACS880-07-0260A-5	132	2.3	SAFUR200F500	2.7	5400	13.5
ACS880-07-0302A-5	160	2.3	SAFUR200F500	2.7	5400	13.5
ACS880-07-0361A-5	160	2.3	SAFUR200F500	2.7	5400	13.5
ACS880-07-0414A-5	160	2.3	SAFUR200F500	2.7	5400	13.5
ACS880-07-0460A-5	250	2.0	2×SAFUR125F500	2.00	7200	18
ACS880-07-0503A-5	250	2.0	2×SAFUR125F500	2.00	7200	18
ACS880-07-0583A-5	315	1.3	2×SAFUR200F500	1.35	10800	27
ACS880-07-0635A-5	315	1.3	2×SAFUR200F500	1.35	10800	27
ACS880-07-0715A-5	400	0.7	3×SAFUR200F500	0.90	16200	40
ACS880-07-0820A-5	400	0.7	3×SAFUR200F500	0.90	16200	40

Drive type	Internal brake chopper		Example brake resistor(s)			
	P_{brcont}	R_{min}	Type	R	E_R	P_{Rcont}
	kW	ohm		ohm	kJ	kW
$U_N = 690 \text{ V}$						
ACS880-07-0061A-7	55	13	SACE15RE13	13.0	435	2
ACS880-07-0084A-7	65	13	SACE15RE13	13.0	435	2
ACS880-07-0098A-7	90	8	SAFUR90F575	8.0	1800	4.5
ACS880-07-0119A-7	110	8	SAFUR90F575	8.0	1800	4.5
ACS880-07-0142A-7	132	6	SAFUR80F500	6.0	2400	6
ACS880-07-0174A-7	160	6	SAFUR80F500	6.0	2400	6
ACS880-07-0210A-7	200	4	SAFUR125F500	4.0	3600	9
ACS880-07-0271A-7	200	4	SAFUR125F500	4.0	3600	9
ACS880-07-0330A-7	285	2.2	SAFUR200F500	2.7	3600	13
ACS880-07-0370A-7	285	2.2	SAFUR200F500	2.7	3600	13
ACS880-07-0430A-7	285	2	SAFUR200F500	3	3600	13
ACS880-07-0470A-7	350	2	2xSAFUR125F500	2	7200	18
ACS880-07-0522A-7	350	2	2xSAFUR125F500	2	7200	18
ACS880-07-0590A-7	350	2	2xSAFUR125F500	2	7200	18
ACS880-07-0650A-7	400	2	2xSAFUR125F500	2	7200	18
ACS880-07-0721A-7	400	1.8	2xSAFUR125F500	2	7200	18

3AXD1000044776

P_{brcont} Maximum continuous braking power. The braking is considered continuous if the braking time exceeds 30 seconds.

R_{min} The minimum allowed resistance value of the brake resistor

R Resistance value for the listed resistor assembly

E_R Short energy pulse that the resistor assembly withstands every 400 seconds

P_{Rcont} Continuous power (heat) dissipation of the resistor when placed correctly

The ratings apply at an ambient temperature of 40 °C (104 °F)

■ Degree of protection of SAFUR resistors

The degree of protection of SAFUR resistors is IP00.

■ Terminals and cable lead-through data

See section [Terminal and lead-through data for the power cables](#) on page 198.

Further information

Product and service inquiries

Address any inquiries about the product to your local ABB representative, quoting the type designation and serial number of the unit in question. A listing of ABB sales, support and service contacts can be found by navigating to www.abb.com/searchchannels.

Product training

For information on ABB product training, navigate to new.abb.com/service/training.

Providing feedback on ABB Drives manuals

Your comments on our manuals are welcome. Navigate to new.abb.com/drives/manuals-feedback-form.

Document library on the Internet

You can find manuals and other product documents in PDF format on the Internet at www.abb.com/drives/documents.

Contact us

www.abb.com/drives

www.abb.com/drivespartners

3AUA0000105718 Rev E (EN) 2015-06-25